

FARMALL 20B,25B

Operator's Manual

52112703

Contents



1. General Notices for Safety

1-1. Before using the tractor	1-1
1-2. Safety Precautions (Read this for safety before using)	
(1) Notices before using the tractor	1-4
(2) Notices when starting Engine	1-7
(3) Notices while operating/using the tractor	1-8
(4) Notices when connecting Implement	1-10
(5) Notices when towing the tractor	1-11
(6) Notices when transporting the tractor	1-11
(7) Notices when servicing the tractor after work	1-12
(8) Notices when handling Diesel Fuel	1-13
(9) Notices when leaving the tractor	1-14
(10) Notices relating to Toxic substances	1-14
1-3. Long-term storage	
(1) Preparation for storage	1-15
(2) Check & Maintenance during storage	1-16
(3) Preparation for Reuse	1-16
1-4. Notices for “Use & Disposal” related to the environment	1-17
1-5. Symbols	1-18
1-6. Safety Decals	
(1) Handling and Maintenance of Safety Decals	1-19
(2) Safety Decals and attaching position	1-19



2. Instruction for Safe operation

(1) The name of each part	2-1
2-1. Boarding and Exiting the tractor	
(1) Boarding the tractor	2-2
(2) Driver’s seat (HST type)	2-2
(3) Seat adjustment	2-3
(4) Seat belt	2-3
(5) Exiting the tractor	2-4
2-2. Safety device	
(1) Hood (Bonnet)	2-5
(2) Fender	2-5
(3) PTO safety cover and protection cap	2-5
(4) Roll-Over Protective Structure (ROPS)	2-6

Contents



3. Instruments and Controls

3-1. Instrument Panel and Switches

- (1) Instrument panel 3-2
- (2) Key switch 3-4
- (3) Turn signal light switch 3-4
- (4) Light switch (optional) 3-5
- (5) Horn switch (if fitted) 3-5
- (6) Hazard warning light switch 3-6
- (7) Throttle lever 3-6
- (8) Brake pedal 3-7
- (9) Parking brake lever 3-7
- (10) HST forward / reverse pedal (HST type) 3-8
- (11) Cruise control lever (HST type) 3-8

3-2. Left / Right-hand side Levers and Pedals

- (1) PTO switch 3-9
- (2) PTO select lever 3-10
- (3) Work light switch 3-10
- (4) Range gear shift lever 3-10
- (5) 4WD lever 3-11
- (6) Differential lock pedal 3-11

3-3. Hydraulic System

- (1) Safety precautions 3-12
- (2) Steering system 3-13
- (3) Hydraulic lift Control 3-14
- (4) Remote control lever and Quick coupler (optional) 3-15
- (5) Hydraulic System Diagram 3-16



4. Operation and Work

4-1. Engine start and stop

- (1) Engine start 4-1
- (2) Start in cold weather 4-2
- (3) Engine stop 4-2

4-2. How to Drive and how to Stop

- (1) How to drive 4-3
- (2) Changing speed 4-4
- (3) Emergency Stop 4-4
- (4) Stopping tractor 4-5
- (5) Driving tractor on the road 4-6
- (6) Parking 4-7

Contents

4-3. How to handle new tractor	
(1) Check points	4-8
(2) Notices in handling new Tractor	4-8
4-4. Attaching Implement	
(1) 3-point linkage	4-9
(2) Power take-off (PTO) shaft	4-13
(3) Hitch and Drawbar (optional)	4-16
(4) 7-Pole connector (optional)	4-17
(5) Technically maximum permissible mass	4-18
(6) Adjusting Wheel tracks and tire replacement	4-19
(7) Tires and Load capacity	4-19
(8) Using Front-end loader (optional)	4-20
(9) Adjusting Steering angle	4-22
(10) Recommended maximum specification of implements	4-23
4-5. Driving Speed	4-24



5. Lubrication and Maintenance

5-1. Access for Maintenance	5-1
5-2. Maintenance Chart	5-2
5-3. Lubricants and Capacity	5-4
5-4. First 50 hour check	5-5
5-5. Check before Starting (Daily check)	
(1) Engine oil	5-6
(2) Fuel tank	5-7
(3) Instrument panel & Indicators	5-7
(4) Turn signal lights, Lights and Horn	5-8
(5) Engine coolant	5-9
(6) Air cleaner (Dry type)	5-9
(7) Cleaning of Radiator and Radiator screen	5-10
(8) Tire air pressure and damage	5-10
(9) Tightening state of Bolts and Nuts of each part	5-11
(10) Adjusting HST control linkage (HST type)	5-11
(11) Adjustment of Brake pedal play	5-12

Contents

5-6. First 50 hour check

- (1) Lubricating grease 5-13
- (2) Cleaning of Radiator and Radiator screen 5-13
- (3) Checking Transmission oil 5-13
- (4) Checking Front axle oil 5-14
- (5) Battery check 5-14
- (6) Air cleaner (Dry type) 5-14
- (7) Hydraulic hoses and Leakage 5-14

5-7. Every 300 hour check

- (1) Replacing Engine oil and Filter 5-15
- (2) Replacing Hydraulic oil filter 5-16
- (3) Tension adjustment of Fan belt 5-17
- (3) Replacing Fuel filter cartridge 5-17
- (4) Replacing Air cleaner element (Dry type) 5-17
- (5) Tension adjustment of Fan belt 5-18
- (6) Toe-in 5-18

5-8. Every 600 hour check

- (1) Changing Front axle oil 5-19
- (2) Changing Transmission oil 5-19
- (3) Replacing Fuel filter cartridge 5-20
- (4) Adjusting Engine Valve clearance 5-20
- (5) Checking Nozzle injection pressure 5-20

5-9. Every 2-year check

- (1) Replacement of Engine coolant 5-21

5-10. General maintenance (When required)

- (1) Air-bleeding from Fuel system 5-22
- (2) Fuse & Main fuse 5-24
- (3) Battery handling and Notices 5-26

5-11. Troubleshooting 5-30



6. Dimension and Specification 6-1

1. General Notices for Safety

1-1. Before using the tractor



※ **Have to read and understand this Operator's manual carefully and always refer to information and prescriptions outlined in this manual to prevent all potential health and safety risks.**

◆ General information for intended use

- Your tractor is designed and manufactured to pull, to carry, to supply the power a variety of mounted or towed equipment **for agriculture**. Do not use the product for other purposes than intended by the manufacturer and outlined in this manual. Do not use this tractor for light/heavy forestry applications.
- Do not use the product beyond its **limits of terrain gradient** and stability than outlined in this manual. Using the tractor beyond these limits may cause a overturning accident.
- Do not use the tractor on higher speeds than allowed by the load of the tractor and road condition. Always choice a **suitable driving speed** to maintain the stability of the tractor.
- Do not use the tractor **near or on soft verges** of canals and brooks or banks and verges that are undermined by rodents. The tractor may sink sideways and roll-over.
- Do not use the tractor on brittle bridge heads and poor bridge floors, These constructions may collapse and cause overturning of the tractor. **Always check out the condition and carrying capacity of bridges and ramps** prior to engage.
- **Do not use the tractor without wearing the seat belt and Roll-Over Protective Structure (ROPS)** during operations where roll-over or tip-over hazards exist. The ROPS will only be fully effective when the driver remains attached to his seat.
- Do not use equipment mounted on the tractor which is not **correctly matching and firmly fixed**. Such equipment may increase the risk for roll-over and hit the tractor when coming loose.
- Do not use the tractor in combination with equipment arbitrary, without **having consulted the specific operator's manual provided with the equipment**. This manual alone cannot provide you with all the information about safety operation of the combination.
- Do not use the tractor beyond its **limits of dynamic stability**. High speed, abrupt maneuvers, and fast and short cornering will increase the risk of roll-over.
- Do not use the tractor for **overloaded pulling work**, in cases where you don't know if the load will yield, for instance when pulling stumps. The tractor may flip over when the stump is not yielding.
- Be extremely cautious when working with the tractor **on forage silos without lateral concrete walls**. A wide track setting may improve the lateral stability of the tractor.
- Be cautious that the **center of gravity of the tractor may increase** when the front-end loader is loaded or the three-point linkage are raised. In these conditions, the tractor may roll-over earlier than expected.
- **Do not step down from the tractor without shutting down the PTO, shifting the transmission to neutral and applying the parking brake.**

- **Never remove or modify or change** the driver's protection device or safety device arbitrary.
- You must take the necessary precautions to always be **aware of the possible presence of bystanders**, certainly when maneuvering in confined areas. Keep people away from the tractor during work. Pay the necessary attention while operating next to public roads or footpaths. Thrown objects can get projected outside the field and hit unprotected people like bikers or pedestrians. Wait until it is clear of bystanders.
- Do not violate the **local traffic rules** related to public roads and highways
- **Do not allow riders** on the tractor; do not allow people standing on the access way or step to the cab when the tractor is moving. Your view to the left will be obstructed and a rider risks to fall from the tractor during unforeseen or abrupt movements.
- **This tractor has only one operator station** and is a one man operated vehicle. Other people on or around the tractor during normal operation are not allowed.
- Always stay clear from implements operating area and especially **do not stand between tractor and trailed vehicle either three-point linkage when operating lift controls**; ensure no bystanders are near these operating areas.
- This tractor may be equipped with a number of sensors to control safety functions. **Do not attempt to bypass any function** on the tractor. You will be exposed to serious hazards, and moreover, the behavior of the tractor may become unpredictable.
- The manufacturer will not be responsible for the damage or safety problems caused by maintenance or repair with non-genuine parts. It must be requested to **use the genuine parts**.
- When cleaning the tractor by using high pressurized water, **do not inject water directly to the electronic parts, wiring, air intake pipe, hot engine or muffler** inside the bonnet.
- Maintenance and repair of the tractor is performed by **skilled technical experts with the proper tools** authorized by the manufacturer.
- For damage or accidents caused by the miss use or operation in violation of these rules, the manufacturer and its distributors **will not have any responsibility and warranty**.
- **Keep this Operator's manual** for future reference at hand (on the tractor).

◆ Safety Mark Description

- In the places where the cautions in usage are required, the marks such as **"DANGER"**, **"WARNING"**, **"CAUTION"** are found.
- You should comply with the description marked on the decals attached on the product or the contents marked with safety mark in this Operator's Manual..



Danger

Danger - This indicates a fatal dangerous situation that may cause a serious injury or death if not avoided.



Warning

Warning - This indicates a potential dangerous situation that may cause a serious injury or death if not avoided.



Caution

Caution - This indicates a potential dangerous situation that may cause a light injury or damage to the properties if not avoided.

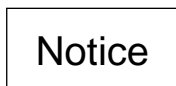

Notice

Notice - This indicates the instructions for right use for the safety of persons or products.

◆ Product Identification

Your tractor has an exclusive chassis number and engine number marked with product serial number tag to identify the product. (See Fig. 1-1)

In case of requesting service or parts from your dealer

Dealer will need chassis serial number, engine serial number, TM number and running hours displayed on the instrument panel. (See Fig. 1-3)

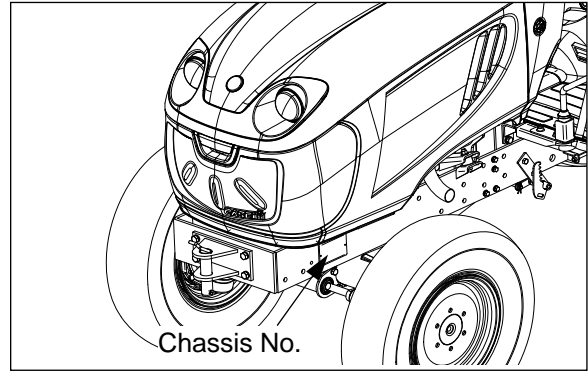

Fig.1-1

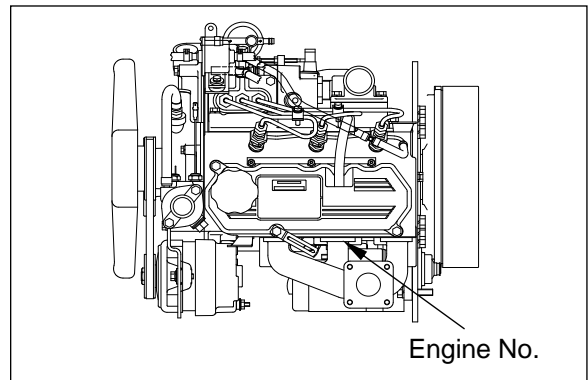

Fig.1-2

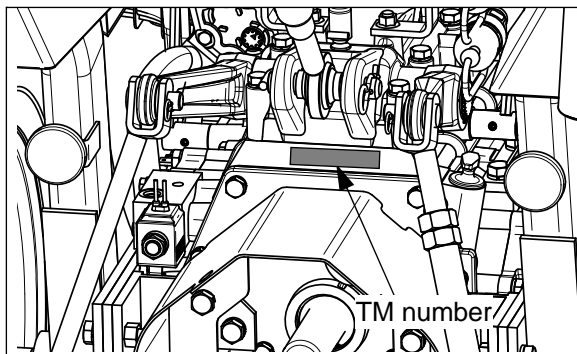

Fig.1-4

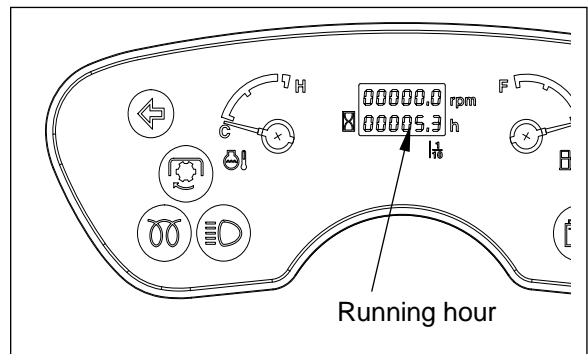
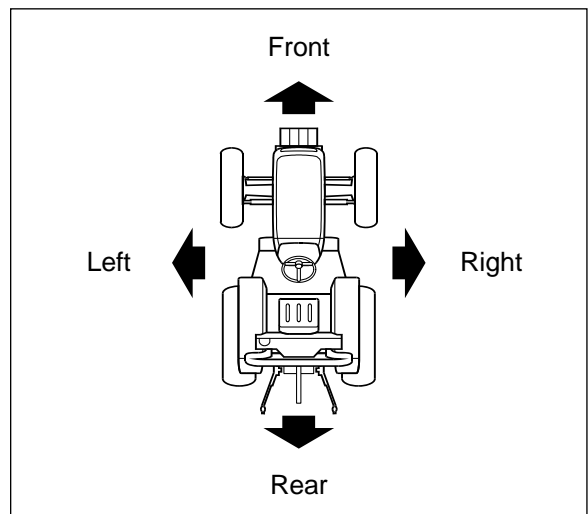

Fig.1-3

◆ Terminology

When reading this Operator's Manual, refer to the right figure for the discrimination of the front/rear/ left/ right direction.



1-2. Safety Precautions - read this for safety before using.

(1) Notices before using the tractor

- **For Safety Instruction** : Before using the tractor, read this Operator's Manual carefully and understand the instructions fully for the safety prevention and right usage of the tractor and then use the tractor safely according to the instructions.

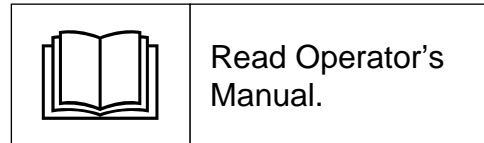

Especially, special cares must be taken for using the tractor in the places where the safety signs such as Danger, Warning, Caution etc. are marked. (See page 1-2)

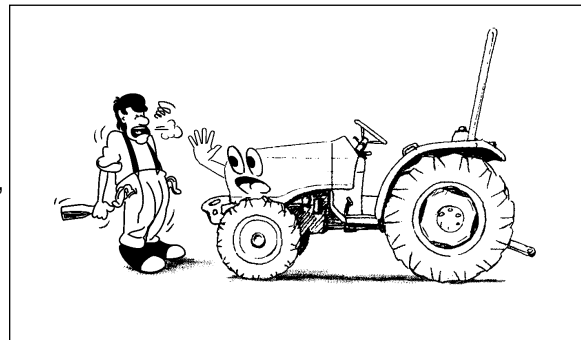

- **Safety Decals** : For right use and personal safety of the operator, the safety decals are attached to the parts related with safety operation. Before using the tractor, comply with the safety instructions. (For further information, refer to "1-6 Safety Decals", See page 1-19)

- **Operator's condition** : The persons such as patients, drunks, people on drugs, etc. are never allowed to operate this tractor. Only educated operators can use the tractor after learning the usage of controls for moving, stopping, turning and other operating.

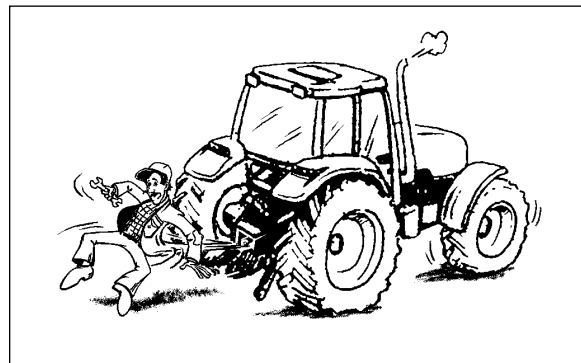

- **Suitable Clothes & Protect Entanglement** : When checking or operating the tractor, wear tight fitting clothes and safety equipment instead of loose or long clothes. Also, slippers, high heel shoes are not suitable for operation. Wear the low shoes or work shoes or boots.



 Warning	▶ Do not approach the rotating shaft such as PTO shaft or cooling fan, especially, with loose clothing and long clothes. The entanglement in rotating shaft can cause serious injury or death.
	▶ Stop the engine and be sure PTO shaft is stopped before getting near it.

- **Keep Riders off** : Riders on the tractor or implements obstruct the operator's view and can be thrown off the tractor. It can cause a serious injury or death. Riders should not be carried on the tractor at any time.

 Warning	▶ Additional seat (where fitted) is used for driver training or instruction. Do not permit anyone to ride on the tractor.
---	---

- **Protect Children** : Pay special attention to children (or a child) while using the tractor or during storage.
 - Make sure children keep a safe distance from the tractor and all implements before using the tractor. Be alert to the presence of children.
 - Do not let children or an untrained person operate the tractor.
 - Do not allow children to approach the tractor while the engine is running.
 - When parking the tractor, remove the ignition key and lower implements to the ground for children's safety.

 Warning	▶ As children are very curious, they may do unexpected movements or actions. Special care must be taken, when operating tractor or equipment.
---	---

- **Periodical Check** : "Lubrication and Maintenance" must be performed periodically. If necessary, do it immediately and if not, it may cause the failure, reduction of product life or physical injury.

* Periodic Lubrication and Maintenance

Fuel, Oil, Filter, Air cleaner, Battery, Belt, Cable, Grease, Pedals such as clutch and brake pedal, Tire air pressure, Wheel bolts, Toe-in, Electrical wirings, other items related to safety.

- **Genuine Parts** : When replacing parts, you must use "Genuine Parts" of LS tractor. Contact your authorized dealer. If not, it may cause a reduction of product life, failure and serious injury.

- **Restrict Maintenance** : If you repair or change some components and settings arbitrary, the performance of the tractor can NOT be guaranteed, and may void the warranty. And also, maintenance of the heavy weighted parts without special tools can cause serious injury. If it is required to check or repair the tractor due to trouble, or if you have any questions for the usage or operation of the tractor, contact your authorized dealer.

* The items that are not allowed to be modified or changed or removed arbitrarily by user are below :



- Protection structures such as PTO cover, Guards, Safety frame (Roll-bar), Cab, etc.
- Engine components, Fuel injection control and setting, etc.
- Automatic control equipment, Lamps, Transmission, Hydraulic valve and pressure settings.
- Other parts that detail and where complicated adjustments are needed.

 Warning	▶ Skilled professional technology is needed for the repair. ▶ For derail maintenance or repair, contact your authorized dealer.
---	--

- **Lamps** : Do not modify the lamps or change the bulb capacity arbitrarily.

 Warning	▶ Modified lamps or change bulb capacity may cause the traffic accident by disturbing approaching driver's views. ▶ If the lamp is blown out, replace it immediately with a genuine part. In case of driving at night, it may cause a traffic accident.
---	--

- **Protective Structures** : For the operator's safety, various protective structures, i.e. Bonnet (Hood), Fan cover, PTO safety cover, PTO shaft protection cap, Roll-bar or another Roll-over Protective Structure, etc are attached on the tractor. If these structures are modified or removed by user arbitrarily, it may cause serious accident. Such behaviors are prohibited strictly.

 Warning	<ul style="list-style-type: none"> ▶ The Protective Structure and interconnecting components are a certified system. Any damage, Fire, corrosion or modification will weaken the structure and reduce your protection. If this occurs, the Protective Structure MUST be replaced with a new one. Contact your authorized dealer for Protective Structure inspection and replacement. ▶ In case of an accident, fire, tip or roll-over, the following MUST be performed by a qualified technician before operating the tractor again. <ul style="list-style-type: none"> - The Protective Structure MUST be replaced. - The mounting or suspension for the Protective Structure , operator seat and suspension, seat belt and mounting components and wiring within the operator's protective system MUST be carefully inspected for damage. - All damaged parts MUST be replaced. ▶ DO NOT attach any device to the Protective Structure for pulling purposes. ▶ DO NOT weld, drill holes, attempt to straighten or repair the protective structure. The modification can reduce the structural integrity of the structure which can cause death or serious injury in the event of fire, tip, roll over, collision or accident and void the warranty.
	

- **Level of protection of the FOPS (Falling Objects Protective Structure)** : This tractor does **NOT** provide protection against falling objects according to OECD code 10 standard. It is recommended to use a certified FOPS structure when working with front-end loaders.
- **Level of protection against hazardous substances** : This tractor does **NOT** provide protection against hazardous substances. Do not use the tractor with crop sprayers in hazardous area.
- **Level of protection of the OPS (Operators Protection Structure)** : This tractor does **NOT** provide protection against
 - low hanging wires and branches in the forest, orchard or construction area, etc
 - toppling trees, primarily in case a rear-mounted tree grab-crane is mounted at the rear of the tractor
 - penetrating objects in the operator's enclosure, primarily in case a winch is mounted at the rear of the tractor.
 - potential risks by using any optional equipment that might be available to deal with those hazards.**NEVER enter or operate these hazardous area without certified Operator Protective Structure installed.**

(2) Notices when starting Engine

- Check each part with reference of “5. Lubrication and Maintenance” in this manual. If necessary, repair or replace it immediately. **Especially, check if safety protection structures or covers are attached originally and the bolts and nuts are tightened well.**
- Before starting, **check again if there are other workers or children around the tractor and implements and keep a safe distance.**
- Start engine and operate the tractor **after sitting on the driver’s seat** correctly with seat belt fastened.
- Place the shuttle lever, transmission gear lever in NEUTRAL and especially check if parking brake is applied.
- Lower the implements on the ground.
- Ensure that rear view mirrors and the other mirrors (if fitted) are adjusted correctly, and check the operation of the headlights and other lights
- Put PTO switch to “OFF” position. If the PTO switch is “ON”, the engine can NOT be started. (See Fig.1-5)
- Depress the clutch pedal fully (if fitted). If not, the start safety switch does not contacted enough and the engine can NOT start.

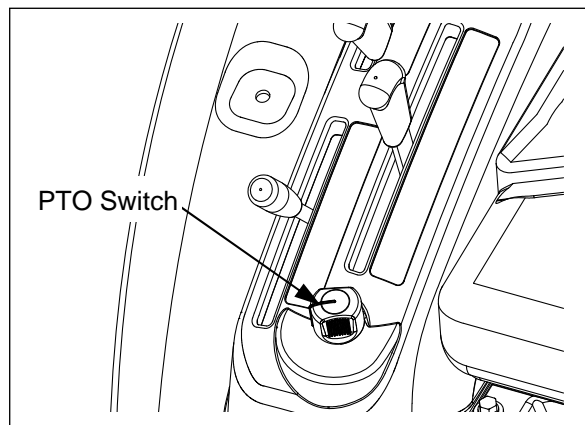
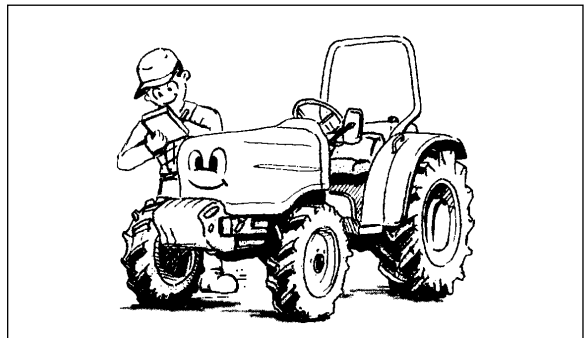

Fig.1-5





Warning



- ▶ Do not start the engine in a closed area. The poisonous exhaust gas can cause fatal damage to the driver or persons around.

(3) Notices while operating/using the tractor

● Ventilation

 Warning	<p>► It is very dangerous to work in a closed area. The poisonous exhaust gas may cause serious damage to the human body. If you should work in this area, make sure to ventilate well and put on the protective mask.</p>
	

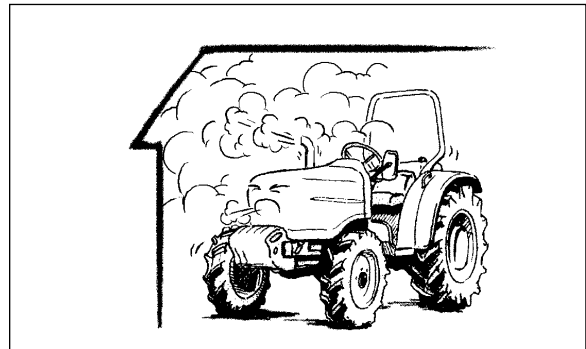

- **Noise and Vibration** : When working between buildings or in confined spaces, the sound pressure level can be increased. Wear suitable ear protectors in high noise level conditions. When working with equipment in the field, Vibration may intensity from the equipment may be increased. To reduce the harm to the body, take a rest periodically.

- Connect left and right brake pedals while driving on the road. (if fitted)
- DO NOT use differential lock device while driving on the road or turning in the field.
- DO NOT ride your foot on the brake pedal or clutch pedal.

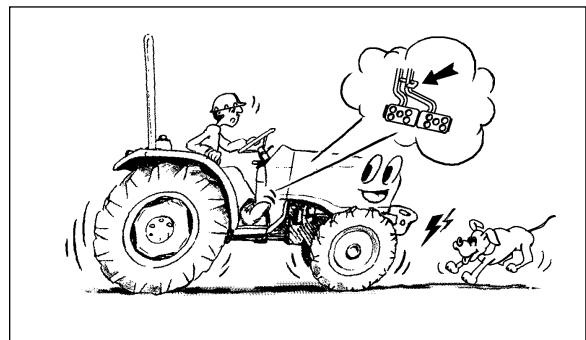

- Lower the driving speed enough before turning a sharp curve. Especially, when you drive the tractor with implements, make the turning radius wider.
- DO NOT start or stop the tractor suddenly. Engage the clutch and brake softly. If not, front wheels can be lifted up and it is very dangerous.
- Do not jump up and down while tractor is moving. When getting off or on the tractor, use the grip or handrail and sub step to prevent falls.

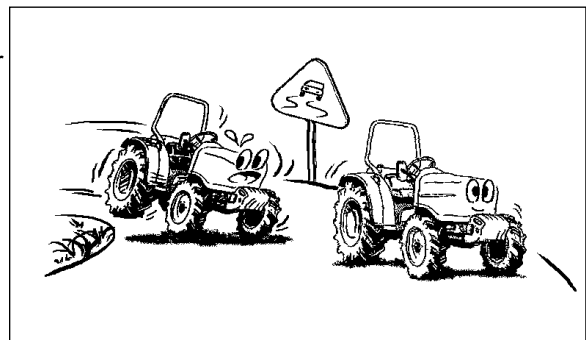

- When driving the tractor in reverse, lower the engine speed. Make sure to check if there is any obstacle or person in the rear.
- DO NOT permit other people and especially children approach within working area while operating tractor and equipment.

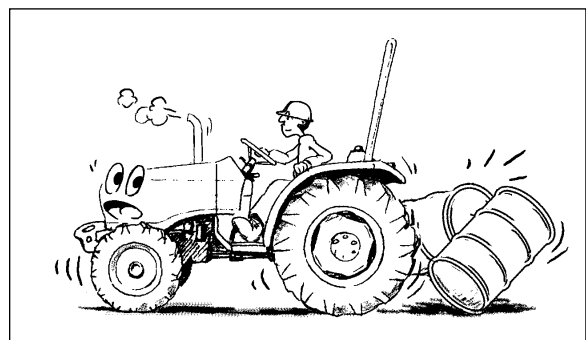

Buy Now



Our support email:

ebooklibonline@outlook.com