

# CC Tractor Operators Manual

5259

Reprinted

**CASE III**



***This symbol means ATTENTION! BECOME ALERT! YOUR SAFETY IS INVOLVED. The message that follows the symbol contains important information about your safety. Carefully read the message. Make sure you fully understand the causes of possible injury or death.***

SB001

IF THIS MACHINE IS USED BY AN EMPLOYEE, IS LOANED, OR IS RENTED, MAKE SURE THAT THE OPERATOR UNDERSTANDS THE TWO INSTRUCTIONS BELOW.

BEFORE THE OPERATOR STARTS THE ENGINE:

1. GIVE INSTRUCTIONS TO THE OPERATOR ON SAFE AND CORRECT USE OF THE MACHINE.
2. MAKE SURE THE OPERATOR READS AND UNDERSTANDS THE OPERATOR'S MANUAL FOR THIS MACHINE.



# WARNING

**IMPROPER OPERATION OF THIS MACHINE CAN CAUSE INJURY OR DEATH.**

BEFORE STARTING THE ENGINE, DO THE FOLLOWING:

1. READ THE OPERATOR'S MANUAL.
2. READ ALL SAFETY DECALS ON THE MACHINE.
3. CLEAR THE AREA OF OTHER PERSONS.

LEARN AND PRACTICE SAFE USE OF MACHINE CONTROLS IN A SAFE, CLEAR AREA BEFORE YOU OPERATE THIS MACHINE ON A JOB SITE.

It is your responsibility to observe pertinent laws and regulations and to follow manufacturer's instructions on machine operation and maintenance.

See your Authorized Case dealer for additional operator's manuals, parts catalogs, and service manuals.

KEEP THIS BOOK FOR FUTURE REFERENCE

# CASE MANUAL

---

Instructions for  
Operation and Care of the

## CASE MODEL "CC" TRACTOR



**TO CASE OWNERS —**

The more thorough knowledge the owner has of his Tractor the better will be the results, and the greater the profit from its use. It is the desire of the J. I. Case Co., that every Tractor should give the highest degree of service and every effort is made toward insuring this service in the design and manufacture of the Tractor. When it passes into the hands of the owner it passes largely beyond the control of the Company. This manual has been prepared with the purpose of giving the owner as much knowledge of the Tractor as possible. The owner and particularly the operator is urged to read and study this manual and to use good judgment in the use and care of his Tractor, and satisfactory service will follow.

**CASE CO.**  
Racine - Wisconsin - U. S. A.

Form 5259 10M 6-39

Fifth Edition

## **SPECIAL SAFETY INSTRUCTIONS**

1. **Do Not Operate New Tractor On Full Load.**  
No fine piece of machinery should ever be loaded to full capacity until it has been run light for a reasonable length of time. **FOR FIRST 50 HOURS this tractor should be RUN AT HALF LOAD OR LESS BEFORE IT IS PUT ON FULL LOAD.**
2. **NEVER GET OFF OR ON TRACTOR WHILE IT IS IN MOTION.**
3. **When the power take-off shaft is used, be absolutely sure that guard furnished is in place. This guard is shown at (8) Fig. (16).**  
If an attempt is made to operate power take-off without guard, operator may be injured by his clothing being caught by the universal joint or the revolving shaft.

**NOTE: IT IS EQUALLY IMPORTANT FOR THE SAFETY OF THE OPERATOR TO HAVE A SUITABLE GUARD ON THE DRIVEN MACHINE, WHICH WILL PREVENT CLOTHING BEING CAUGHT BY THE REAR UNIVERSAL JOINT OR THE REVOLVING SHAFT.**

**NOTE: IF POWER TAKE-OFF OR OTHER POWER MACHINERY IS DELIVERED WITHOUT PROPER GUARDS, APPLY FOR SAME TO YOUR NEAREST CASE DEALER OR CASE BRANCH HOUSE.**

4. When cranking an engine the handle of the crank should be pulled upward with the left hand so the operator's hand will be in a position to avoid being struck by the starting crank if there is a reversal of the direction of the engine from any cause.
5. When starting any tractor do not engage the clutch quickly. Always engage clutch gradually so the engine will pick up the load slowly. This is particularly necessary when the tractor is going up a steep hill, climbing out of ditches or when hitched to some heavy or difficult load. Never hitch a tractor to a stump or other object by means of a long chain or rope with slack so that when the tractor moves forward it will jerk into the load.
6. When working on steep side hills, any tractor may tip over sideways, especially when the wheel on the lower side strikes a hollow, hole or ditch. The center of gravity on Case tractors is low and they are especially stable but when operating under unusual conditions they must be operated with reasonable care.
7. It is always advisable to reduce the speed of the tractor when turning.
8. When going up a steep hill or climbing out of a ditch or gully, any tractor is liable to raise its front wheels off the ground, if the full power is suddenly applied or by quickly engaging the clutch. Under such conditions the momentum of the flywheel adds to the power of the engine, and to avoid possibility of danger under these conditions the operator should keep his hand on the clutch lever, (or foot on the clutch pedal if foot clutch is used) engaging the power of the engine slowly and be prepared at all times to disengage the clutch promptly should the front wheels raise off the ground. The same precautions must be taken if the tractor becomes mired down by being driven into a soft bog, a mud hole or ditch.
8. **Read Instruction Book Carefully.**  
The paragraphs of the following printed instructions are numbered in the order that the different operations should be done. Numbers on the illustrations correspond with the paragraph numbers and in many cases the parts referred to in the instructions are shaded or emphasized on the illustration so that the directions can be easily followed.

### **Ordering Parts.**

When ordering parts be sure to give Serial Number and Model of tractor and name and number of Part Ordered.

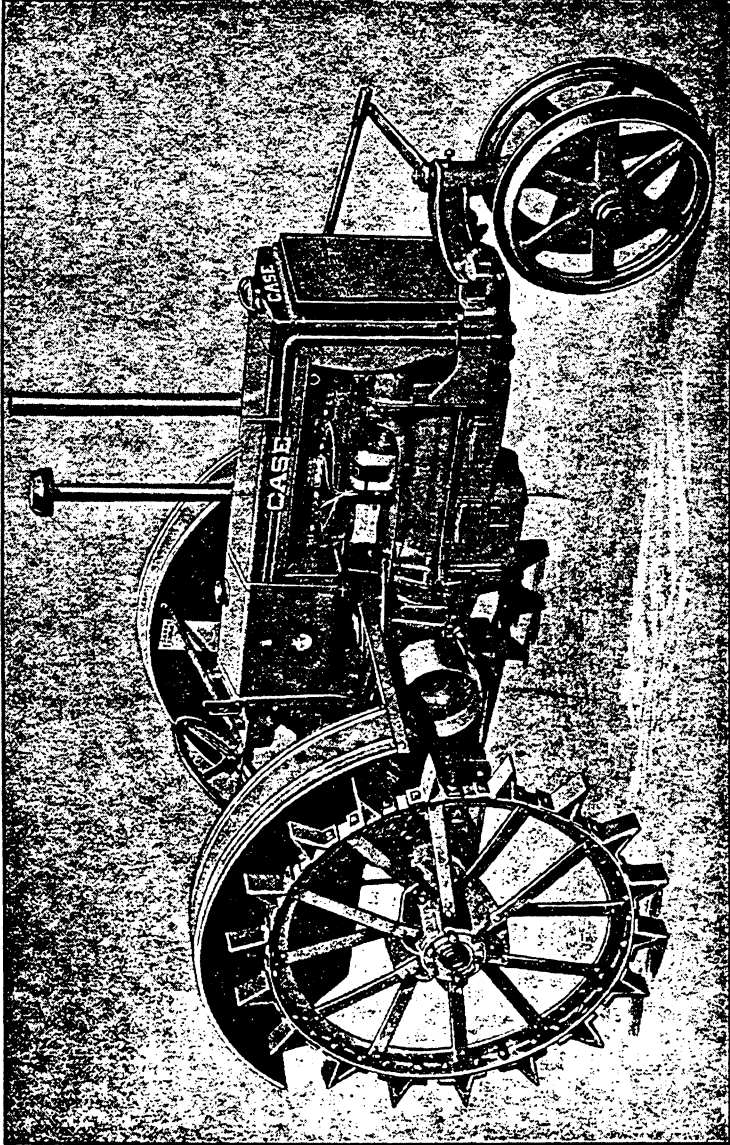
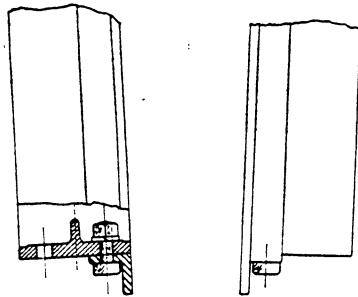

Fig. 1. Model "CC" Tractor

## « « CONTENTS » »

	Fig. No.	Page No.
Air Cleaner .....	22	37
Air Vent Holes .....	5	7
Bearing, Front Wheel .....	32	50
Bearings, Taking Play out of .....	30	47, 48
Bevel Gears, Adjusting .....	42, 43	63, 64
Brake, Pulley .....	25	41
Brake, Hand .....	37	58
Brake, Independent .....	26	42
Carburetor .....	20	33
Choke .....	5	7
Clutch .....	38, 39	59, 60
Crankcase Breather .....	18	31
Crankcase Filling .....	8	15, 16
Cranking Engine .....	6	10
Cylinder Barrels, Replacing .....	29	45, 46
Differential Shaft .....	45	66
Drive Chains .....	46	67
Engine, Starting .....		9
Fan .....	24	39
Fenders .....	12	22, 23
Fuel Strainer .....	5	7, 8, 9
Gears, Shifting .....	7	12
Governor .....	23	38
Guard, Power Take-Off .....	16	28, 29
Hitch .....	16, 17	29, 30
Ignition .....		32
Lift Bail .....	15	27, 28
Lubrication .....	8	15 to 20
Lugs .....		5, 73
Main Bearings .....		48
Manifold Lever .....	6	10, 13, 14
Motor Lift .....	14	25, 26, 27
Oil, Crankcase .....	8	15, 16
Oil, Transmission .....	8	15, 18
Piston Pins .....		49
Pulley, Belt .....	25	41
Power Take-Off .....	13	24, 25
Radiator Curtain .....	21	35
Radiator Screen .....	21	35
Radiator—Winter Operation, Anti-Freeze Solution .....		35, 36
Rear Axle Bearing Adjustments .....	33 to 36	51 to 58
Removing Oil Pan .....	4	6, 17
Rubber Tires .....		68
Safety First .....		69
Service Suggestions .....		70, 71, 72
Shaft, Belt Pulley .....	42	63, 65
Skid Rings .....	2, 3	5
Sliding Gear Shaft .....	44	64, 65
Spark Plugs .....	19	9, 32
Special Grouters, Rims and Attachments .....		73
Speeds .....		12
Speeds, Transmission .....	7	12
Steering Gear .....	31	49
Tractor, Splitting .....	40, 41	61, 62
Valve Adjustment .....	27	43
Valve Reconditioning .....	28	44, 45
Valve Rockers, Oiling .....		18
Valves, Timing .....		43
Water Pump .....	24	39
Water in Crank Case .....		16
Wheel Spacing .....	9	20
Wheels, Heavy Front .....	47	68
Wheel Weights .....		69



No. 2. Position of Front Wheel Skid Rings for Flat Ground Operation.

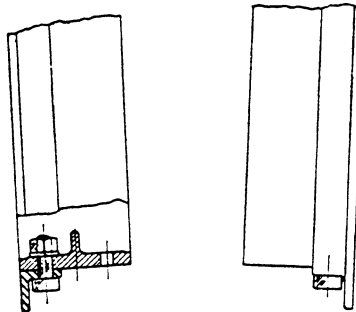

Fig. 3. Position of Front Wheel Skid Rings for Riding Listed Ridges.

**NOTE:** The paragraphs of the following instructions are numbered and in many cases the paragraph numbers correspond with numbers on the illustrations and also the parts referred to in the instructions are shaded or emphasized on the illustrations so that the directions can be easily followed.

It is the desire of J. I. Case Company that every tractor should be delivered not only mechanically perfect but as clean in appearance as the day it was shipped from the factory. When possible, box-cars will be used in making shipments and at times this requires the removal of some parts from the tractor to save space in loading. Put these parts on fastening securely, using lock washers on all bolts.

This Tractor is shipped set up as a three wheel machine. The two large rear wheels are turned in narrow position, 48" tread when shipped, and 12" hub extensions, to change the spacing of rear wheels, are furnished as regular equipment. The Tractor in the 48" tread is a splendid plowing tractor.

#### Rear Wheels and Lugs

Rear wheels of the narrow type with 36 steel spade lugs 5" high are furnished as standard equipment.

As optional equipment in lieu of standard equipment either open or closed type wheels may be ordered with various optional lug equipment.

(See special grouters, rims, etc., on page No. 73)

#### Front Wheel Skid Rings

Fig. 2 For ease of steering in cultivating and plowing, put the skid rings on with the extending leg of angle toward the inside of front wheels, as shown in Fig. 2.

Fig. 3 An extra set of holes are provided in the wheels so that the skid rings can be put on as shown in Fig. 3 for riding listed ridges.

Wheel weights for the regular front wheels can be obtained at a low price for use with the tractor mounted four row planters, if found desirable. Under other exceptional conditions these wheel weights may be found desirable, and can be added whenever the operator wishes them.

#### Skid Rings.

1. It is important that the skid rings for the front wheels be put on with the vertical flange of skid ring toward the inside of the wheel.

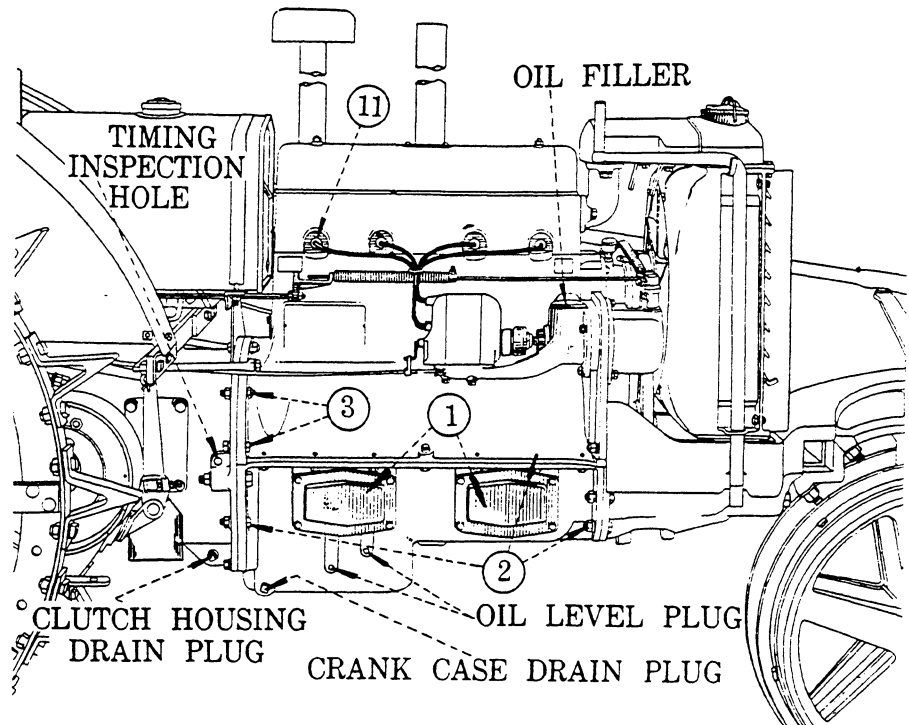

Fig. 4. R. H. Side of Case "CC" Tractor

**Inspection.**

2. Inspect tractor carefully to make sure that nothing has become loose, or has been broken or damaged in shipment. Remove cinders, dirt or paint from moving parts where it might cause parts to bind.
3. Fig. 5. Make sure that air vent holes in caps of fuel tanks are open.
4. Work the clutch lever to see that clutch does not stick and that pulley brake shoe does not bind on belt pulley and that both engage properly when operated. For detailed instructions, see Figs. 25, 38 and 39.

THE COMPLETE OBSERVANCE of one simple rule would prevent many thousand serious injuries each year. THAT RULE IS: "NEVER ATTEMPT TO CLEAN, OIL, OR ADJUST A MACHINE WHILE IN MOTION.

—National Safety Council.



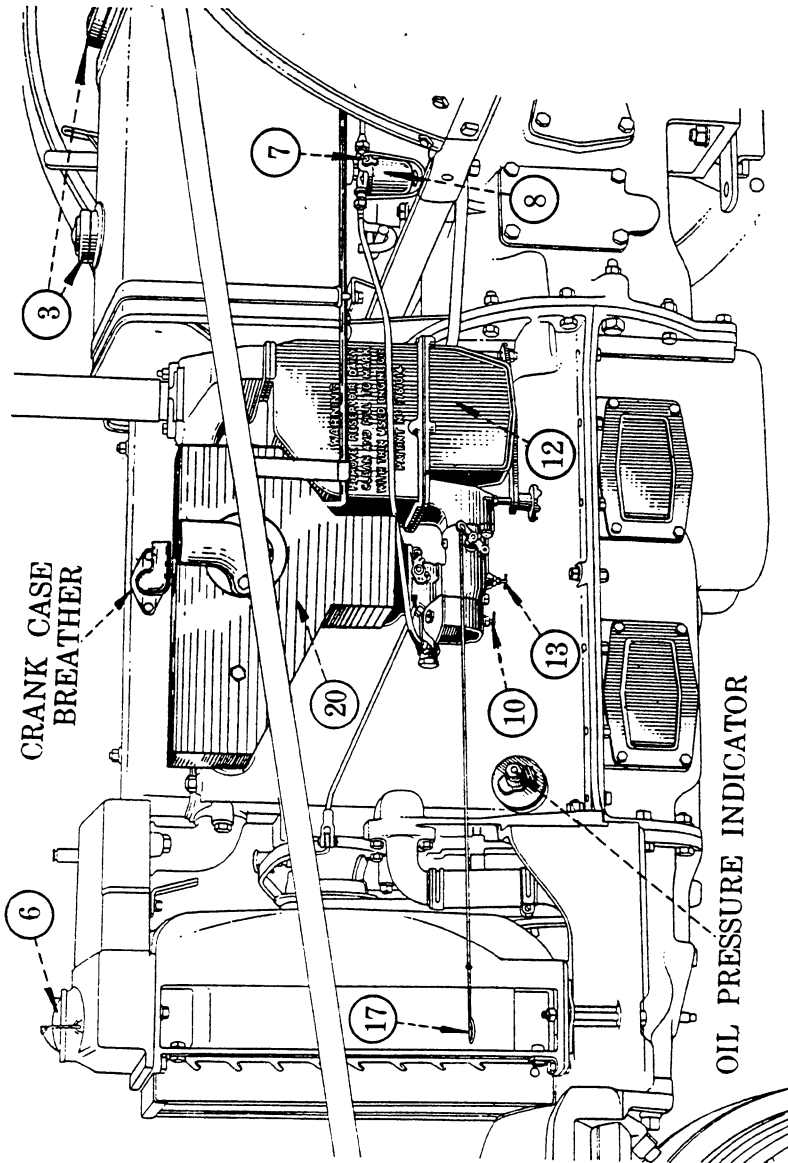

Fig. 5. L. H. Side of Case "CC" Tractor

**Lubrication of New Tractor.**

5. Check over the lubrication of the entire tractor following Fig. 8 and according to instructions given on pages 15 to 20 before starting a new tractor.

**Buy Now**



Our support email:

[ebooklibonline@outlook.com](mailto:ebooklibonline@outlook.com)