

OPERATOR'S MANUAL

LANDSCAPE RAKES

LR5060

LR5048L

LR5072

LR5060L

LR5084

LR5096

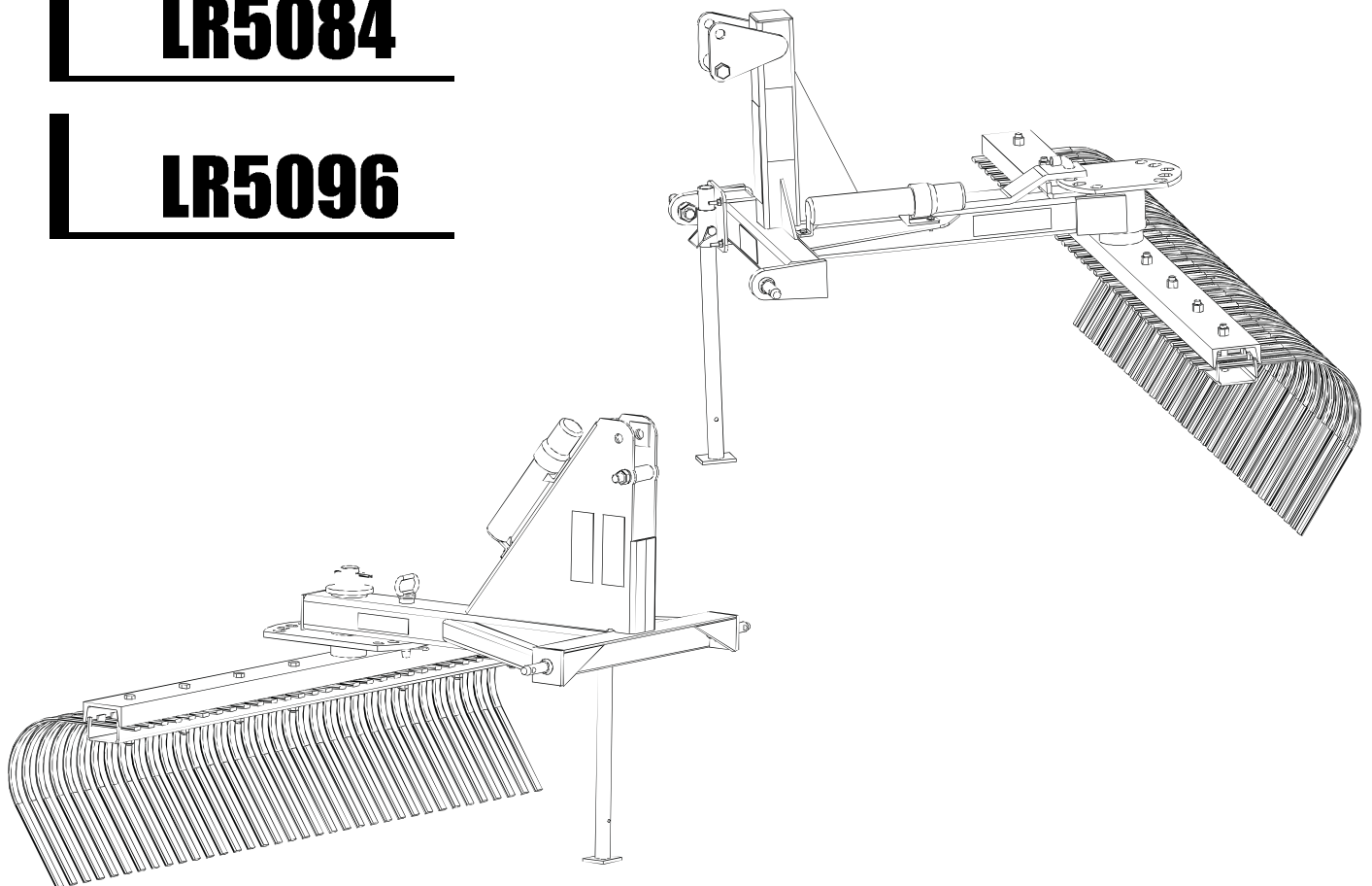

FRONTIER
EQUIPMENT™

TO THE DEALER:

Assembly and proper installation of this product is the responsibility of the Frontier dealer. Read manual instructions and safety rules. Make sure all items on the Preparation Check List in the Operator's Manual are completed before releasing equipment to the owner.

TO THE OWNER:

Read this manual before operating your Frontier equipment. Keep this manual handy for ready reference. Require all operators to read this manual carefully and become acquainted with all adjustments and operating procedures before attempting to operate the equipment. Replacement manuals can be obtained from your selling dealer.

The equipment you have purchased has been carefully engineered and manufactured to provide dependable and satisfactory use. Like all mechanical products, it will require cleaning and upkeep. Lubricate the unit as specified. Please observe all safety information in this manual and safety decals on the equipment.

For service, your authorized Frontier dealer has trained mechanics, genuine Frontier service parts, and the necessary tools and equipment to handle all of your service needs.

Use only genuine Frontier service parts. Substitute parts will void the warranty and may not meet standards required for safe and satisfactory operation. Record the model number and serial number of your equipment in the spaces provided:

Model _____ **Date of Purchase** _____

Serial Number: (see Safety Decal section for location) _____

Provide this information to your dealer to obtain correct repair parts.

Throughout this manual, the term **IMPORTANT** is used to indicate that failure to observe procedures can cause damage to equipment. The terms **CAUTION**, **WARNING** and **DANGER** are used in conjunction with the Safety-Alert Symbol, (a triangle with an exclamation mark), to indicate the degree of hazard for items of personal safety.



This is the safety alert symbol. it is used to alert you to potential personal injury hazards. Obey all safety messages that follow this symbol to avoid possible injury or death.



Indicates an imminently hazardous situation that, if not avoided, will result in death or serious injury.



Indicates a hazardous situation which, if not avoided, could result in death or serious injury.



Indicates a potentially hazardous situation that, if not avoided, may result in minor or moderate injury.

IMPORTANT Is used to address practices not related to personal injury.

NOTE Indicates helpful information.

2 Introduction

TABLE OF CONTENTS

INTRODUCTION	2
GENERAL INFORMATION	3
SPECIFICATIONS	4
SAFETY RULES	5-6
DEALER CHECK LISTS	7
SAFETY DECALS	8-9
OPERATION	10-12
MAINTENANCE	12-13
ASSEMBLY INSTRUCTIONS	13
PARTS LIST	14-15
BOLT TORQUE CHART	16
BOLT SIZE CHART & ABBREVIATIONS	17

All information, illustrations and specifications in this manual are based on the latest information available at the time of publication. The right is reserved to make changes at any time without notice.

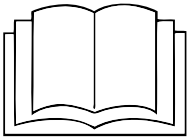

This Operator's Manual should be regarded as part of the machine. Suppliers of both new and second-hand machines must make sure that this manual is provided with the machine.

GENERAL INFORMATION

The purpose of this manual is to assist you in operating and maintaining your Landscape Rake. Read it carefully. It furnishes information and instructions that will help you achieve years of dependable performance.

These instructions have been *compiled from* extensive field experience and engineering data. Some information may be general in nature, due to unknown and varying operating conditions. However, through experience and these instructions, you should be able to develop procedures suitable to your particular situation.

The illustrations and data used in this manual were current at the time of printing. However, due to possible inline production changes, your machine may vary slightly in detail. We reserve the right to redesign and change the machines as may be necessary without notification.

Throughout this manual, references are made to right and left directions. These are determined by standing behind the tractor facing the direction of forward travel.

SPECIFICATIONS

Model	LR5060	LR5072	LR5084	LR5096	LR5048L	LR5060L
Dimensions						
Working Width, in. (cm)	60 (152.4)	72 (182.88)	84 (213.36)	96 (243.84)	48 (121.92)	60 (154.4)
Weight						
Operating, lb (kg)	248 (112.49)	272 (123.38)	287 (130.18)	324 (146.96)	186 (84.37)	195 (88.45)
Shipping per stand, lb (kg)	581 (263.77)	629 (285.57)	659 (299.19)	733 (332.78)	457 (207.48)	475 (215.65)
Tractor Requirements						
PTO hp	50 Max	50 Max	50 Max	50 Max	18 Max	18 Max
Tines						
Quantity	30	36	42	48	24	30
Dimensions	1.00 x 0.3125	1.00 x 0.3125	1.00 x 0.3125	1.00 x 0.3125	1.00 x 0.3125	1.00 x 0.3125
Spacing, in. (cm)	1 (2.54)	1 (2.54)	1 (2.54)	1 (2.54)	1 (2.54)	1 (2.54)
Hitch						
Type	Cat. 1	Cat. 1	Cat. 1	Cat. 1	Cat. 1	Cat. 1
iMatch™ Compatibility	Yes	Yes	Yes	Yes	Yes	Yes
Raking Angle						
Positions Forward	5	5	5	5	5	5
Positions Reverse	5	5	5	5	5	5
Degrees Forward	15° Left or Right	15° Left or Right	15° Left or Right	15° Left or Right	24.5° Left or Right	24.5° Left or Right
Degrees Reverse	15° Left or Right	15° Left or Right	15° Left or Right	15° Left or Right	24.5° Left or Right	24.5° Left or Right
Pivot						
Degrees	360	360	360	360	360	360
Duty						
Type	Standard	Standard	Standard	Standard	Economy	Economy
Parking Stand						
Standard with machine	Yes	Yes	Yes	Yes	Yes	Yes
Shipping						
Configuration	Partially assembled & palletized	Partially assembled & palletized	Partially assembled & palletized	Partially assembled & palletized	Partially assembled & palletized	Partially assembled & palletized
Setup Time						
Labor hours	.25	.25	.25	.25	.25	.25
Warranty						
Time period	1-year (excluding wear parts)	1-year (excluding wear parts)	1-year (excluding wear parts)	1-year (excluding wear parts)	1-year (excluding wear parts)	1-year (excluding wear parts)

SAFETY RULES



ATTENTION! BECOME ALERT! YOUR SAFETY IS INVOLVED!



Safety is a primary concern in the design and manufacture of our products. Unfortunately, our efforts to provide safe equipment can be wiped out by an operator's single careless act.

In addition to the design and configuration of equipment, hazard control and accident prevention are dependent upon the awareness, concern, judgment, and proper training of personnel involved in the operation, transport, maintenance and storage of equipment.

It has been said "The best safety device is an informed, careful operator." We ask you to be that kind of operator.



!LEA EL INSTRUCTIVO!

Si no lee Ingles, pida ayuda a alguien que si lo lea para que le traduzca las medidas de seguridad.

TRAINING

- Safety instructions are important! Read all attachment and power unit manuals; follow all safety rules and safety decal information. (Replacement manuals and safety decals are available from your dealer.) Failure to follow instructions or safety rules can result in serious injury or death.
- If you do not understand any part of this manual and need assistance, see your dealer.
- Operators must be instructed in and be capable of the safe operation of the equipment, its attachments, and all controls. Do not allow anyone to operate this equipment without proper instructions.
- Never allow children or untrained persons to operate equipment.

PREPARATION

- Always wear relatively tight and belted clothing to avoid getting caught in moving parts. Wear sturdy, rough-soled work shoes and protective equipment for eyes, hair, hands, hearing, and head; and respirator or filter mask where appropriate.
- Make sure attachment is properly secured, adjusted, and in good operating condition.
- Power unit must be equipped with ROPS or ROPS cab and seat belt. Keep seat belt securely fastened. Falling off power unit can result in death from being run over or crushed. Keep foldable ROPS system in "locked up" position at all times.
- A minimum 20% of tractor and equipment weight must be on the tractor front wheels when attachments are in

transport position. Without this weight, tractor could tip over, causing personal injury or death. The weight may be attained with a loader, front wheel weights, ballast in tires or front tractor weights. Weigh the tractor and equipment. Do not estimate.

TRANSPORTATION

- Always comply with all state and local lighting and marking requirements.
- Never allow riders on power unit or attachment.
- Do not operate or transport on steep slopes.
- Use extreme care and reduce ground speed on slopes and rough terrain.
- Do not operate or transport equipment while under the influence of alcohol or drugs.

OPERATION

- Never go underneath equipment (lowered to the ground or raised) unless it is properly blocked and secured. Never place any part of the body underneath equipment or between moveable parts even when the engine has been turned off. Hydraulic system leak down, hydraulic system failures, mechanical failures, or movement of control levers can cause equipment to drop or rotate unexpectedly and cause severe injury or death.
- Always comply with all state and local lighting and marking requirements.
- Operate only in daylight or good artificial light.
- Keep bystanders away from equipment.
- Keep hands, feet, hair, and clothing away from equipment while engine is running. Stay clear of all moving parts.
- Power unit must be equipped with ROPS or ROPS

(Safety Rules continued on next page)

Buy Now



Our support email:

ebooklibonline@outlook.com