

<b>Page Number</b>	<b>Page Title</b>	<b>Page Reference</b>
01-000-TOC	ENGINE, FUEL AND EXHAUST SYSTEM	01-000-TOC
02-000-TOC	STEERING SYSTEM	02-000-TOC
03-000-TOC	DRIVE TRAIN SYSTEM	03-000-TOC
04-000-TOC	BRAKE SYSTEM	04-000-TOC
05-000-TOC	HYDRAULIC SYSTEM	05-000-TOC
06-000-TOC	ELECTRICAL SYSTEM	06-000-TOC
07-000-TOC	CAB	07-000-TOC
08-000-TOC	CHASSIS	08-000-TOC
09-000-TOC	DECALS	09-000-TOC
10-000-TOC	WHEELS	10-000-TOC
11-000-TOC	IMPLEMENT LIFT SYSTEM	11-000-TOC
12-000-TOC	ACCESSORIES	12-000-TOC

Page Number	Page Title	Page Reference
01-0001	FILTER AND BELT GUIDE	244569
01-0002	SHORT BLOCK	T09C26N18D0011
01-0003	CYLINDER HEAD	T09C26N18D0012
01-0004	CYLINDER HEAD COVER	T09C26N18D0013
01-0005	INLET MANIFOLD	T09C26N18D0014
01-0006	EXHAUST MANIFOLD	T09C26N18D0015
01-0007	CYLINDER BLOCK	T09C26N18D0016
01-0008	BEARING - UNDER SIZE	T09C26N18D0017
01-0009	OIL PAN	T09C26N18D0018
01-0010	REAR PLATE	T09C26N18D0019
01-0011	TIMING GEAR CASE	T09C26N18D0020
01-0012	HANGER	T09C26N18D0021
01-0013	VALVES AND ROCKER SHAFT	T09C26N18D0022
01-0014	CAMSHAFT	T09C26N18D0023
01-0015	PISTON	T09C26N18D0024
01-0016	PISTON - OVERSIZE	T09C26N18D0025
01-0017	CRANKSHAFT	T09C26N18D0026
	E4CGWB09 FOR CAB TRACTORS	
01-0018	CRANKSHAFT	T09C26N18D0056
	E4CGWB10 FOR NON CAB TRACTORS	
01-0019	OIL PUMP	T09C26N18D0027
01-0020	WATER PUMP	T09C26N18D0028
	E4CGWB09 FOR CAB TRACTORS	
01-0021	WATER PUMP	T09C26N18D0058
	E4CGWB10 FOR NON CAB TRACTORS	
01-0022	COOLING FAN	T09C26N18D0029
01-0023	INJECTION NOZZLE	T09C26N18D0030
01-0024	INJECTION NOZZLE - COMPONENTS	T09C26N18D0037
01-0025	INJECTION PUMP	T09C26N18D0031
01-0026	INJECTION PUMP - COMPONENTS	T09C26N18D0038
01-0027	FUEL PRESSURE LINES	T09C26N18D0032
01-0028	ADAPTER	T09C26N18D0033
01-0029	STARTER AND ALTERNATOR	T09C26N18D0034
	E4CGWB09 FOR CAB TRACTORS	
01-0030	STARTER AND ALTERNATOR	T09C26N18D0064
	E4CGWB10 FOR NON CAB TRACTORS	
01-0031	ALTERNATOR - COMPONENTS	T09C26N18D0040
	E4CGWB09 FOR CAB TRACTORS	
01-0032	ALTERNATOR - COMPONENTS	T09C26N18D0070
	E4CGWB10 FOR NON CAB TRACTORS	
01-0033	STARTER - COMPONENTS	T09C26N18D0039
01-0034	ENGINE ELECTRICAL	T09C26N18D0035
01-0035	GASKET SET ASSEMBLY	T09C26N18D0036
01-0036	RADIATOR - PLATFORM	T09C26N18D0071
01-0037	RADIATOR - PLATFORM	T09C26N18D0072
01-0038	RADIATOR - CAB	T09C26N18D0073
01-0039	RADIATOR - CAB	T09C26N18D0074
01-0040	MUFFLER	T09C26N18D0075
01-0041	AIR CLEANER	T09C26N18D0076
01-0042	FUEL TANK - PLATFORM	T09C26N18D0077
01-0043	FUEL TANK - PLATFORM	T09C26N18D0078
01-0044	FUEL TANK - CAB	T09C26N18D0079
01-0045	FUEL TANK - CAB	T09C26N18D0080
01-0046	HAND THROTTLE CONTROL - POWERSHUTTLE AND SYNCROSHUTTLE	T09C26N18D0081
01-0047	HAND THROTTLE CONTROL - HYDROSTATIC	T09C26N18D0082
01-0048	CRUISE CONTROL - HYDROSTATIC	T09C26N18D0203
01-0049	CRUISE CONTROL - HYDROSTATIC	T09C26N18D0204

1643 COMPACT TRACTOR  
1600FIL

5

1600FIL

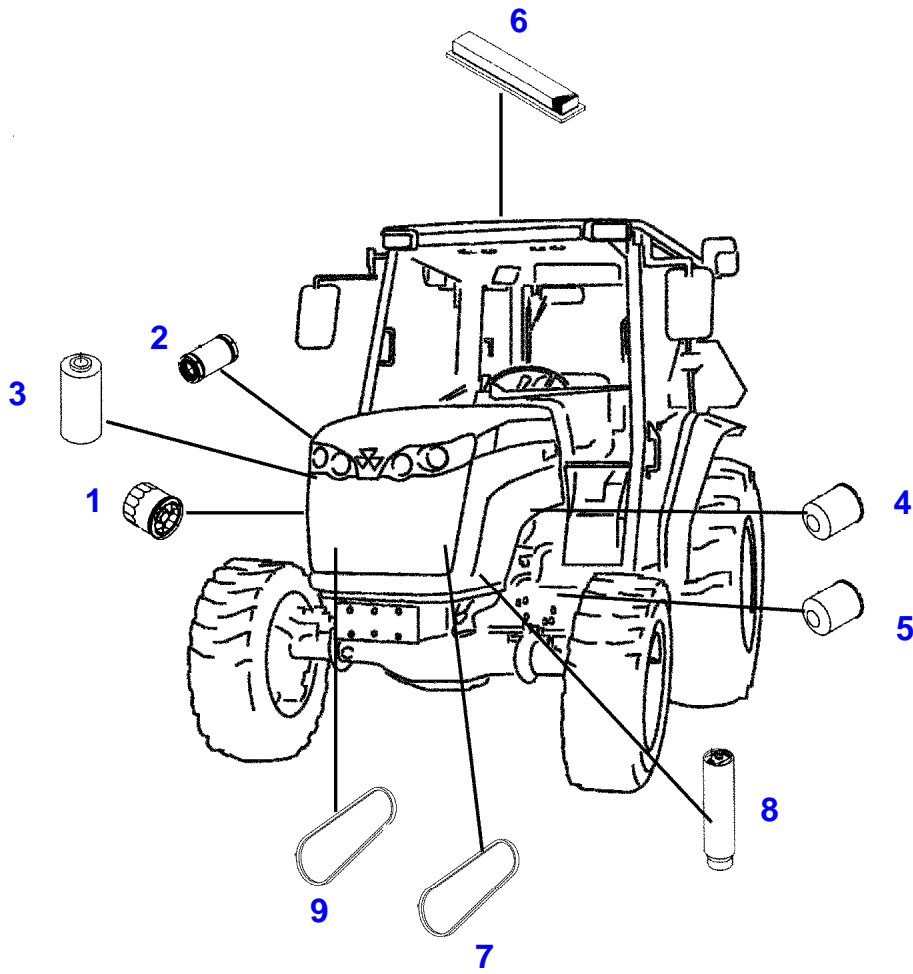

Item	Part Number	Qty	Description Comments	Technical Specification
1	3757038M2	1	ENGINE OIL FILTER ENGINE	
2	6242781M91	1	INNER ELEMENT	
	6242573M92	1	AIR FITR.ELEMENT OUTER	
3	3702815M1	1	FUEL FILTER	
4	6255330M1	1	OIL FILTER HYDRAULIC OIL	
5	3608996M91	1	CARTRIDGE HYDRAULIC OIL	
6	6243528M2	1	AIR FILTER CAB	
7	6243798M1	1	V-BELT AIR CONDITIONER COMPRESSOR	
8	6244522M91	1	AIR CONDITIONING RECEIVER DRIER	
9	6258697M1	1	V BELT ENGINE FAN E4DEWB10, E4DEWB11, E4DEWB12 AND E4DEWB13 1652, 1655	R5 A 43.5

1643 COMPACT TRACTOR  
MFC10783

---

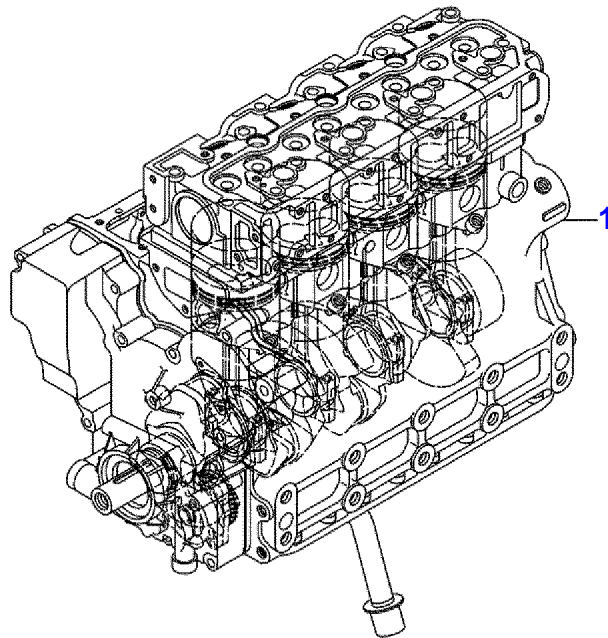

MFC10783

---

Massey Ferguson

1643 COMPACT TRACTOR

651900

SHORT BLOCK

Page01-0002

---

Item	Part Number	Qty	Description Comments
1	6256017M91	1	SHORT BLOCK

1643 COMPACT TRACTOR  
MFC10784

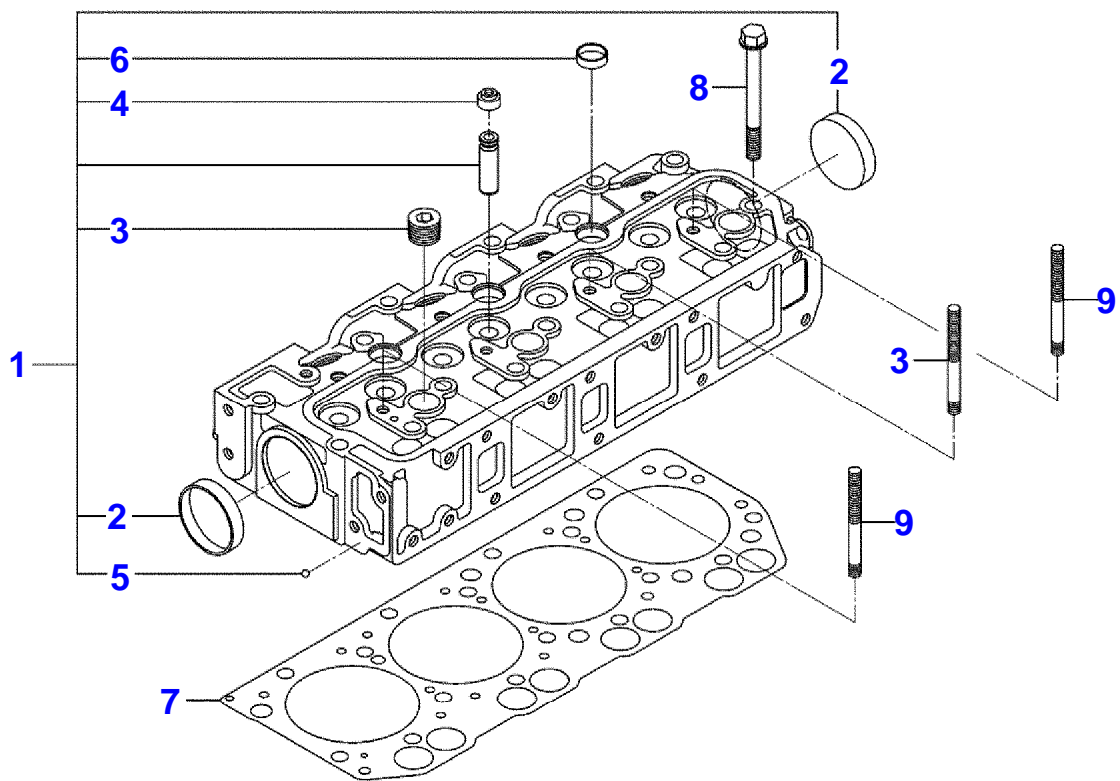

MFC10784

<b>Item</b>	<b>Part Number</b>	<b>Qty</b>	<b>Description Comments</b>	<b>Technical Specification</b>
1	6256302M95	1	CYLINDER HEAD	ASM
2	3710542M1	2	SEALING CUP	?50 MM
3	3707877M2	4	PIPE PLUG	1/2"
4	3710256M1	8	VALVE OIL SEAL	
5	3711713M1	1	BALL	
6	3710543M1	3	SEALING CUP	?20 MM
7	3607102M1	1	CYLINDER HEAD GASKET	
8	3710536M1	18	HEXAGONAL HEAD BOLT	M10 X 92 (1.25)
9	3607420M1	3	STUD BOLT	M8 X 71 (1.25)



1643 COMPACT TRACTOR  
MFC10785

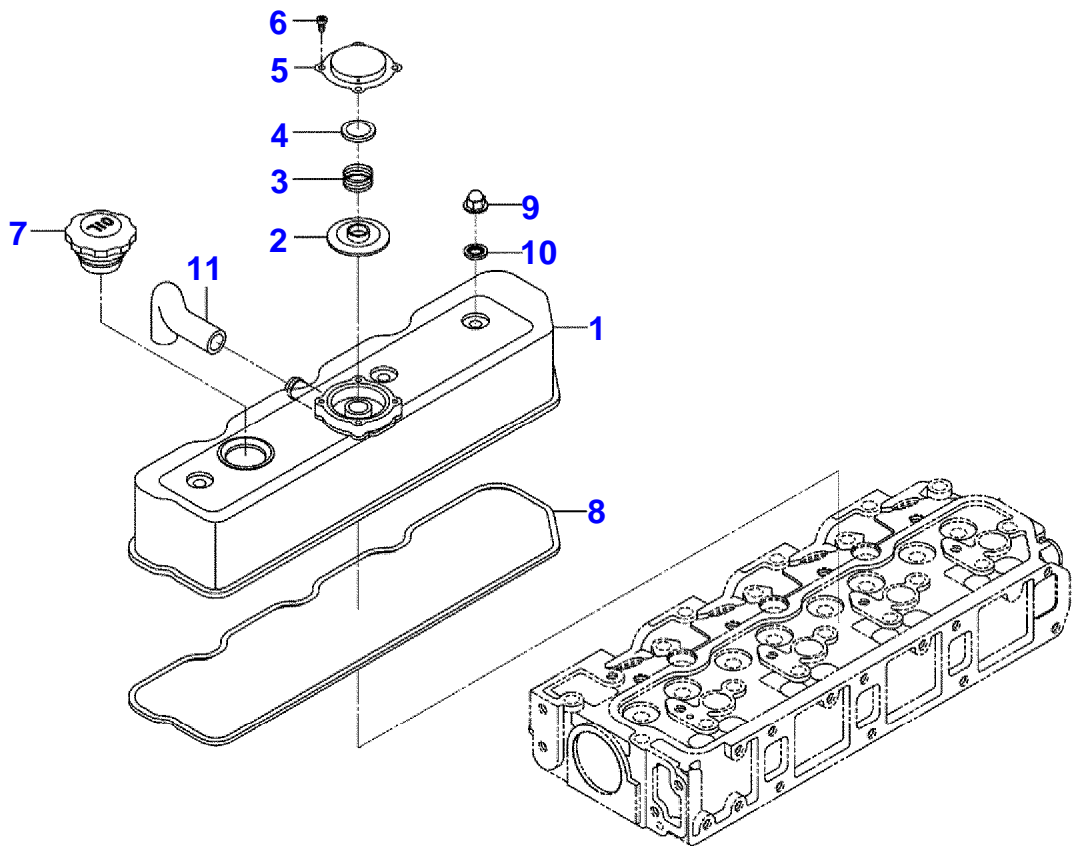

MFC10785

<b>Item</b>	<b>Part Number</b>	<b>Qty</b>	<b>Description Comments</b>	<b>Technical Specification</b>
1	3607103M91	1	CYLINDER HEAD COVER	
2	3607106M1	1	RUBBER FLANGE	
3	3607108M1	1	SPRING	
4	3607109M1	1	SPRING SEAT	
5	3607110M1	1	BLOW BY COVER	
6	3710529M1	4	HEXAGONAL HEAD BOLT	4 X 8"
7	3710188M1	1	OIL FILLER CAP	
8	3607105M1	1	CYLINDER HEAD COVER SEAL	
9	3710127M2	3	CAP NUT	M8
10	4267629M1	3	SEAL	
11	3607088M2	1	RUBBER HOSE	

1643 COMPACT TRACTOR  
MFC10786

---

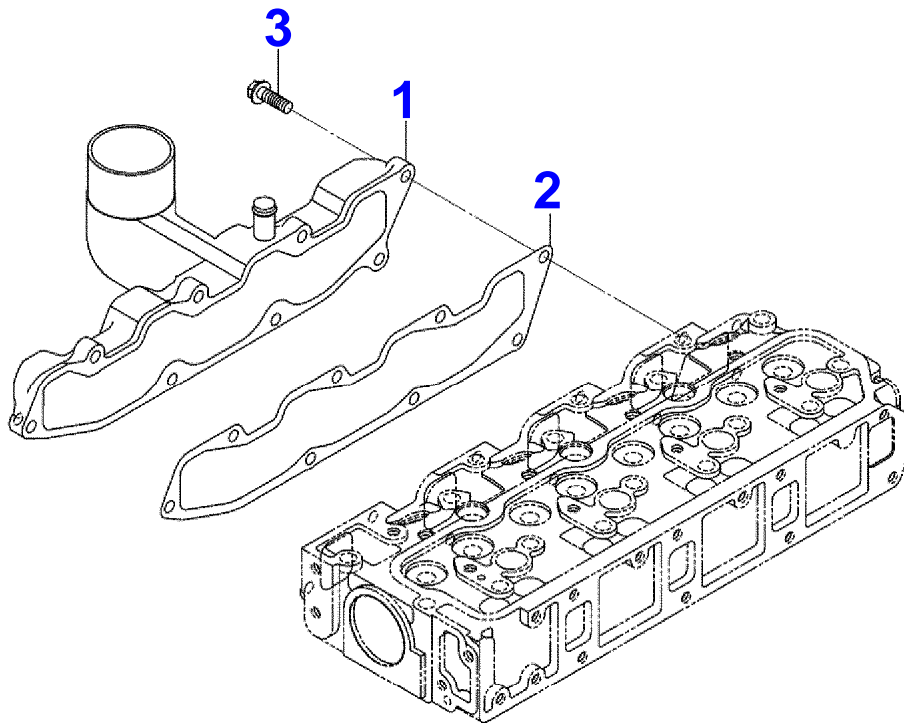

MFC10786

<b>Item</b>	<b>Part Number</b>	<b>Qty</b>	<b>Description Comments</b>
1	3607176M91	1	INLET MANIFOLD
2	3607178M1	1	INLET MANIFOLD GASKET
3	4267568M1	8	HEXAGON FLANGE BOLT

1643 COMPACT TRACTOR  
MFC10787

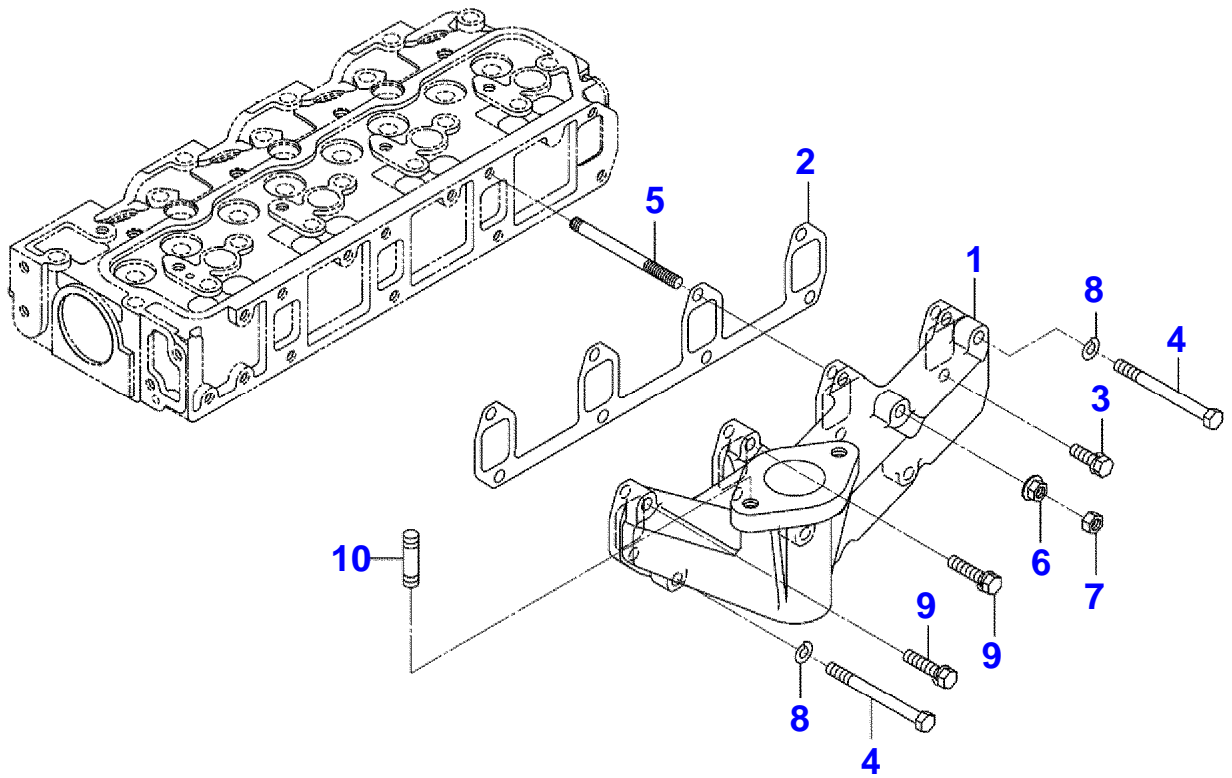

MFC10787

<b>Item</b>	<b>Part Number</b>	<b>Qty</b>	<b>Description Comments</b>	<b>Technical Specification</b>
1	6243084M1	1	EXHAUST MANIFOLD	
2	3607180M1	1	EXHAUST MANIFOLD GASKET	
3	3702273M1	1	HEXAGONAL HEAD BOLT	
4	3704594M1	2	BOLT	
5	3607087M1	3	STUD BOLT	M8 X 85
6	4260467M1	3	HEX NUT	M8
7	1440203X1	3	HEX NUT	M8
8	SN3723	2	LOCKWASHER	5/16"
9	3607227M1	2	HEXAGONAL BOLT	M8 X 35
10	3756141M1	2	STUD BOLT	M10 X 25

**Buy Now**



Our support email:

[ebooklibonline@outlook.com](mailto:ebooklibonline@outlook.com)