

Page Title	Page Number
CYLINDER BLOCK - A4.236	2
CYLINDER HEAD - A4.236	4
CRANKSHAFT - A4.236	8
CYLINDER HEAD COVER - A4.236	12
AIR INDUCTION AND EXHAUST SYSTEM - A4.236 ENGINE	14
TIMING GEAR - A4.236	16
LUBRICATING OIL FILTER - A4.236	20
LUBRICATING OIL SUMP - A4.236	22
BALANCER UNIT - A4.236	24
WATER PUMP - A4.236	26
FUEL OIL LIFT PUMP - A4.236	28
FUEL INJECTION EQUIPMENT - A4.236	30
ALTERNATOR POSITIONER - A4.236	32
JOINTS AND GASKETS - A4.236	34
ENGINE INSTALLATION - A4.236 ENGINE	36
ELECTRICAL EQUIPMENT	38
STARTER-LUCAS - LUCAS	42
STARTER-LUCAS - LUCAS	44
ALTERNATOR-LUCAS - LUCAS	46
BATTERY	48
COOLING SYSTEM	50
FUEL TANK AND ATTACHMENTS	52
FUEL FILTERS AND PIPES	54
KIT - DUAL FUEL FILTERS - 3A ONLY	56
AIR FILTER	60
AIR FILTER-OIL BATH AIR FILTER - OIL BATH AIR FILTER	62
EXHAUST SYSTEM - VERTICAL	66
EXHAUST SYSTEM - HORIZONTAL	68
THROTTLE CONTROLS	70
INSTRUMENT PANEL AND INSTRUMENTS	74
SHEET METAL-PANEL WIRING - PANEL WIRING	76
DUAL CLUTCH	78
SPLIT TORQUE CLUTCH	80
CLUTCH PEDAL AND LINKAGE	82
8 SPEED CONSTANT MESH TRANSMISSION-HOUSING - HOUSING	84
8 SPEED CONSTANT MESH TRANSMISSION-GEAR TRAIN - GEAR TRAIN	88
8 SPEED SYNCHROMESH TRANSMISSION-FORK AND GEAR SHIFTRAIL - FORK AND GEAR SHIFT RAILS	92
8 SPEED SYNCHROMESH TRANSMISSION-GEAR TRAIN - GEAR TRAIN	96
8 SPEED SYNCHROMESH ZF TRANSMISSION-HOUSING - HOUSING	100
8 SPEED SYNCHROMESH ZF TRANSMISSION-FORK AND GEARSHIFT RAIL - FORK AND GEAR SHIFTRAIL	102
8 SPEED SYNCHROMESH ZF TRANSMISSION-MAIN SHAFT - MAIN SHAFT	104
8 SPEED SYNCHROMESH ZF TRANSMISSION-SYNCHROMESH - SYNCHROMESH TRANSMISSION	106
8 SPEED SYNCHROMESH ZF TRANSMISSION-COUNTER SHAFT - COUNTER SHAFT	108
MULTIPOWER CONSTANTMESH TRANSMISSION-HOUSING - HOUSING	110
MULTIPOWER CONSTANTMESH TRANSMISSION-GEAR TRAIN - GEAR TRAIN	114
MULTIPOWER CONSTANTMESH TRANSMISSION-OIL FLOW - OIL FLOW	118
12 SPEED TRANSMISSION - HOUSING	120
SHIFT LEVERS-12 SPEED TRANSMISSION - 12 SPEED TRANSMISSION	122
12 SPEED TRANSMISSION-FORK AND GEAR SHIFTRAIL - FORK AND GEAR SHIFT RAILS	124
12 SPEED TRANSMISSION-INPUTSHAFT - INPUT SHAFT	126

TABLE OF CONTENT

00

12 SPEED TRANSMISSION-MAIN SHAFT - MAIN SHAFT	128
12 SPEED TRANSMISSION-COUNTERSHAFT - COUNTERSHAFT	130
TRANSMISSION-TRANSMISSION OIL PIPE - TRANSMISSION OIL PIPE	134
EPICYCLIC UNIT-HEAVY DUTY - HEAVY DUTY	136
SHIFT LEVER	138
MULTIPOWER CONSTANTMESH TRANSMISSION-SHIFT CONTROL - SHIFT CONTROL	142
PTO-DRIVE MECHANISM-SINGLE SPEED - SINGLE SPEED	144
PTO-DRIVE MECHANISM-TWO SPEED - TWO SPEED	146
PTO PULLEY - CODE 557 832	148
PTO PULLEY AND GUARD - CODE 557 833	150
PTO-COVER ASSEMBLY	154
IPTO-PIPES AND COVER	156
IPTO-CLUTCH AND VALVES	158
REAR AXLE-SPACER	162
REAR AXLE CENTRE HOUSING	164
REAR AXLE-ATTACHMENTS - ATTACHMENTS	166
REAR AXLE-DIFFERENTIAL	168
REAR AXLE-DIFFERENTIAL LOCK MECHANISM	172
REAR AXLE- DIFFERENTIAL LOCK PEDAL	174
REAR AXLE-HOUSING	176
WET BRAKES	178
BRAKE PEDALS AND LINKAGE	180
HANDBRAKE	182
REAR WHEELS - PRESSED STEEL WHEELS	184
WEIGHTS - CODE 557 818- REAR WHEEL WEIGHTS - 1ST SET	188
FRONT WHEELS	190
WEIGHTS - CODE 557 812- FRONT WHEEL WEIGHTS - 16AND 18WHEELS	192
FRONT AXLE-NORMAL DUTY - NORMAL DUTY	194
FRONT AXLE-HEAVY DUTY - HEAVY DUTY	198
AXLE SUPPORT	202
STEERING GEAR	204
STEERING LINKAGE	208
CONVERSION KIT - MANUAL TO POWER STEERING	212
STEERING HYDRAULIC LINES	214
STEERING PUMP-PLESSEY - PLESSEY	216
STEERING PUMP-AIR EQUIPEMENT - AIR EQUIPMENT	218
STEERING CYLINDER	220
STEERING CYLINDER	222
HYDRAULIC LIFT PUMP	224
HYDRAULIC PUMP-STRAINER UNIT - STRAINER UNIT	230
HYDRAULIC PUMP-PRESSURE CONTROL VALVE - PRESSURE CONTROL VALVE	232
HYDRAULIC PUMP-MULTIPOWER - MULTIPOWER	234
HYDRAULIC PUMP-AUXILIARY - AUXILIARY	236
HYDRAULICS,PUMP CONTROL-MK3A - MK3A	240
OIL COOLER AND FILTER - INCLUDED IN KIT 1810 476M91	244
OIL COOLER - FOR USE WHEN G.S.P.T.O. IS FITTED	250
OIL FILTER - MICRONIC FILTRATION	254
PRESSURE REGULATOR VALVE	256
HYDRAULIC LIFT COVER	258
LIFT ARMS	260
DRAFT AND POSITION CONTROLS	264
RESPONSE CONTROLS	266
TOP LINKS - CAT II	268
LOWER LINKS - CAT II	272

TABLE OF CONTENT

LOWER LINKS - CAT 11	270
FRONT HITCH	276
CHAIN STABILISER AND EXTENSION KIT - CODES 557 835 / 557 836	278
SWINGING DRAWBAR - CODE 557 906 HEAVY DUTY	280
SHEET METAL	282
SHEET METAL-GRILLE - FOR USE WITH CODES 1739 103,1739 106,1739 111,AND 1739 112	286
SHEET METAL-FENDERS WITHOUT SAFETY FRAME - FENDERS WITHOUT SAFETY FRAME	288
GUARDS PTO AND ALTERNATOR	292
FOOTSTEP	294
TOOLS	298
EMBLEMS	300
SPEED CHARTS	302
CIGAR LIGHTER	304
SEAT-SPRING SUSPENSION - SPRING SUSPENSION	306
SEAT-DE LUXE - DE LUX TYPE	308
SEAT-SABLE - SABLE	310
SEAT-GRAMMER - GRAMMER	312
HORN AND MIRRORS	314
WEIGHTS - CODE 557 864- FRONT END WEIGHTS	316
FRONT LIGHTING EQUIPMENT	318
REAR LIGHTING EQUIPMENT - UP TO SER. NO 214012	322
REAR LIGHTING EQUIPMENT - FOR USE WITH CODES 1739 103,1739 106,1739 111,AND 1739 112	328
WORK LIGHT	330
ASSISTOR RAM KIT - CODE 557 829	332
AUTOMATIC HITCH - CODE 557 903	334
AUTOMATIC HITCH WITH DRAWBAR FRAME - CODE 557 904	336
PRESSURE CONTROL COUPLER - CODE 557 908	340
SUB FRAME,BOLT KIT AND WEIGHTS - CODE 557 806	342
SUB FRAME,BOLT KIT AND WEIGHTS - CODE 557 808	344
36 KG WEIGHT AND BOLT KIT - CODE 557 809	346
TOW PIN - CODE 557 811	348
WEIGHTS - CODE 557 813- FRONT WHEEL WEIGHTS - 19 WHEELS	350
WEIGHTS - CODE 557 862- FRONT WHEEL WEIGHTS - OUTER - 16 AN D 18 WHEELS	352
WEIGHTS - CODE 557 863- FRONT END WEIGHTS	354
WEIGHTS - CODE 557 815- REAR WHEEL WEIGHTS - 2ND SET	356
OIL PIPE KIT - CODE 557 856	358
OIL PIPE KIT	360
OIL PIPE KIT - CODE 557 878	362
SINGLE SPOOL VALVE - CODE 557 750	364
DUAL SPOOL VALVE - CODE 557 751	366
SPOOL VALVE SLICE CONVERSION KIT - CODE 557 752	368
DETENT KIT - CODE 557 800	370
BRACKET AND FITTINGS KIT - CODE 557 754	372
HYDRAULIC SELECTOR VALVE KIT - CODE 557 761	374
TRAILER TIPPING KIT	376
OUTLET HOSE KIT-SINGLE SPOOL - SINGLE SPOOL	378
OUTLET HOSE KIT-DOUBLE SPOOL - DOUBLE SPOOL	380
CONNECTOR ASSEMBLY KIT - CODE 557 762	382
SUPPLY HOSE KIT - CODE 557 757	384

3-0050-002-C

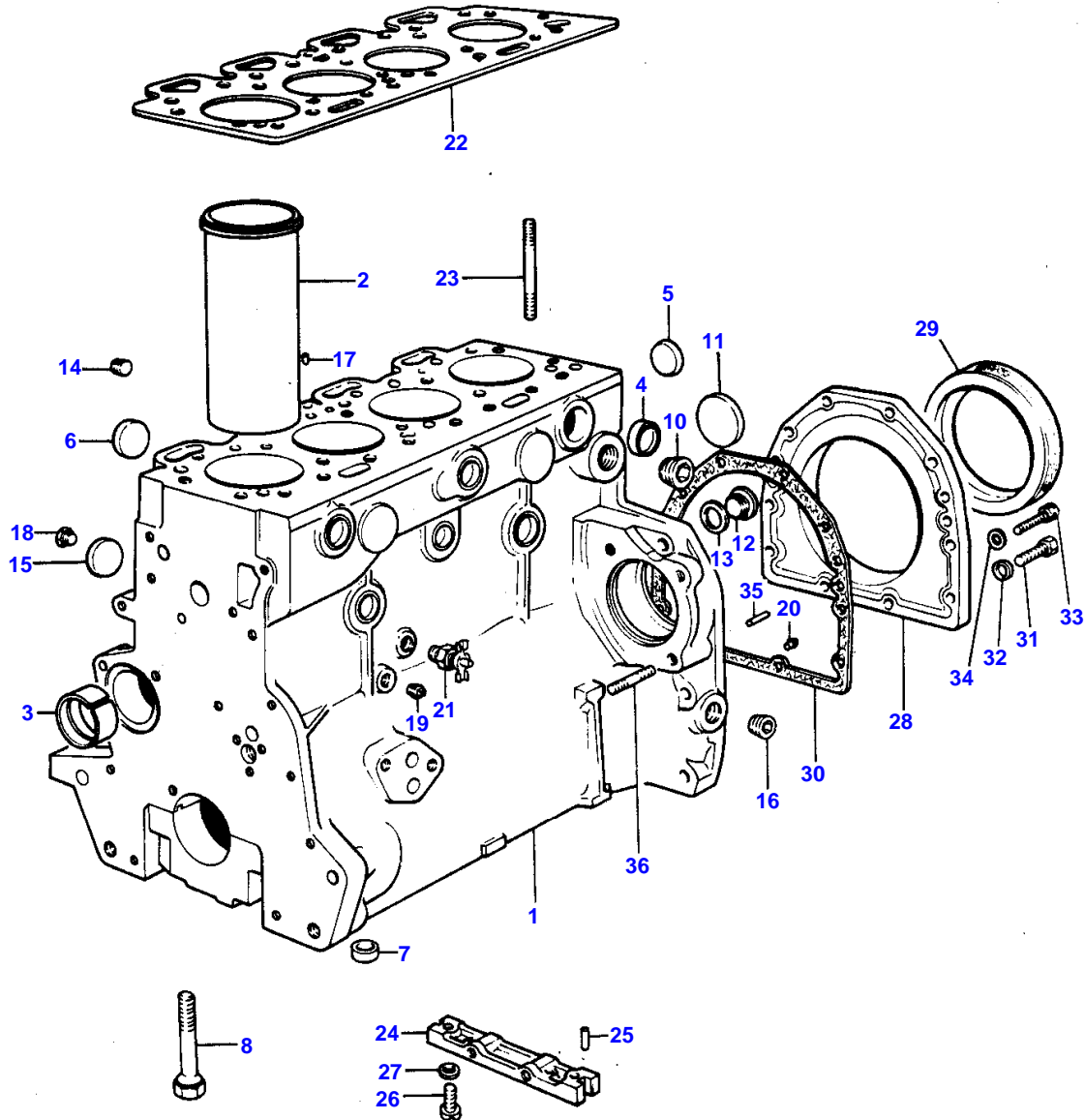

MASSEY FERGUSON

MF 275 TRACTOR, ->| 221522 (GB) - 819669

819669

CYLINDER BLOCK - A4.236

2

Item	Part Number	Qty	Description	Comments
				A4.236
1	61676	1	Block	
2	31358393	4	Liner	(A)
	31358394	X	Liner	(B)
3	31134132	1	Bush	(1)
4	0650563	6	Plug	(1)
5	0650563	2	Plug	(1)
6	0650618	4	Plug	(1)
7	33142111	10	Thimble	(1)
8	32166329	10	Bolt	(1)
10	0650588	2	Plug	
11	32416105	1	Plug	
12	0650582	1	Plug	
13	0920130	1	Washer	
14	32114501	1	Plug	
15	0650577	4	Plug	
16	0650588	1	Plug	
17	32417134	1	Plug	
18	32161114	1	Plug	
19	0650594	1	Plug	
20	32452113	1	Pointer	
21	31419	1	Cock	
22	36812338	1	Gasket	
23	32526312	2	Stud	
24	36277831	1	Bridge Piece	
25	32811408	2	Joint	
26	2176369	2	Screw	
27	0920521	2	Washer	
28	37513851	1	Housing	
29	2415391	1	Seal	
30	36817157	1	Joint	
31	0746211	10	Bolt	
32	0920003	10	Washer	
33	2172530	2	Capscrew	
34	33112111	2	Washer	
35	0350009	2	Dowel	
36	0826481	3	Stud	

(A)
PRESS FIT

(B)
SLIP FIT

3-0075-002-A

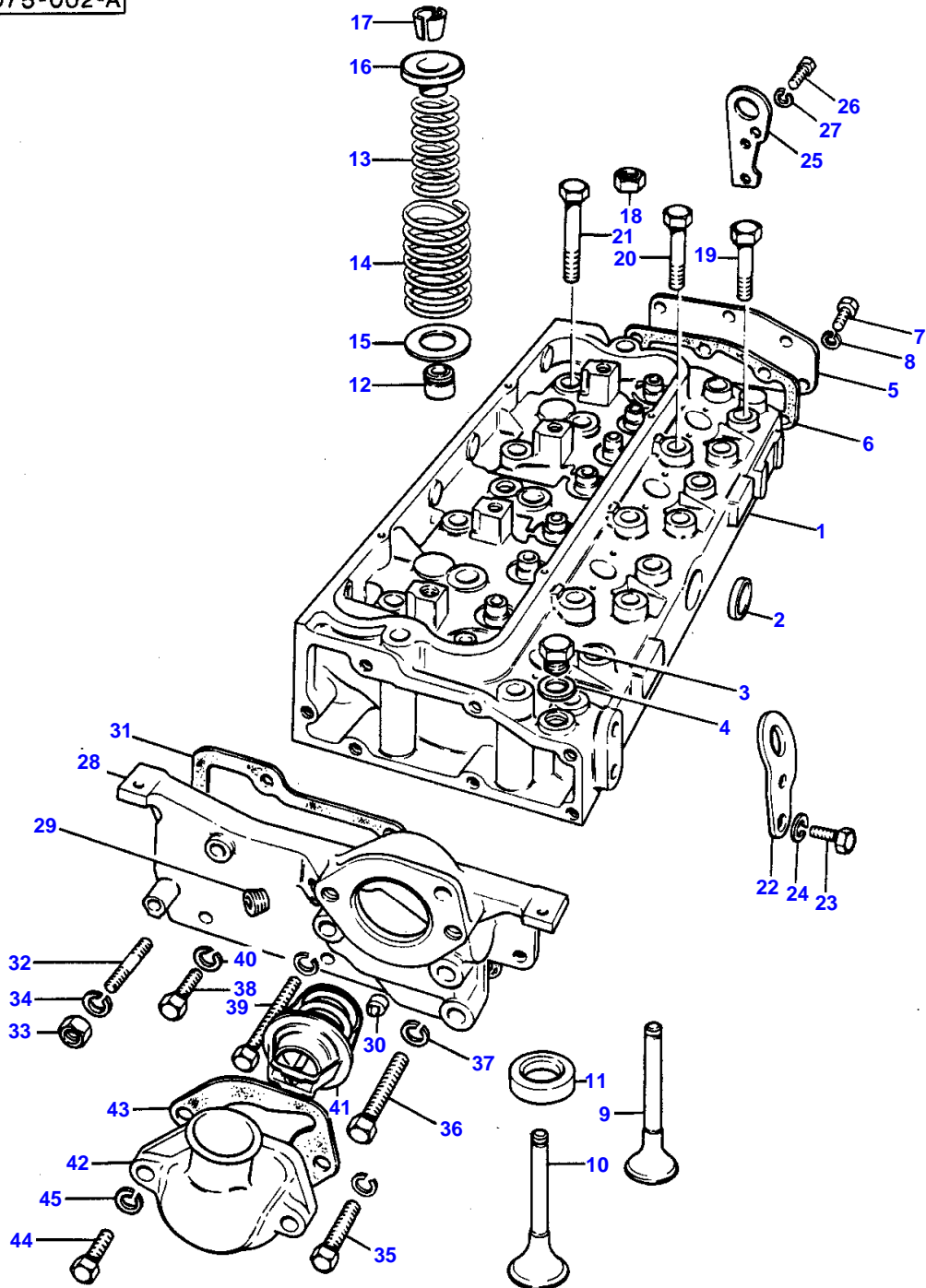

CYLINDER HEAD - A4.236

Item	Part Number	Qty	Description	Comments
				A4.236
1	A5BD2383	1	Cylinder Head	
2	0650563	1	Plug	(1)
3	0650203	1	Plug	(1)
4	2411157	1	Washer	(1)
5	37553142	1	Cover	(1)
6	36851409	1	Joint	(1)
7	0746254	6	Setscrew	(1)
8	0920053	6	Washer	(1)
9	31431641	4	Valve Inlet	(1)
	31431401	X	Valve Inlet	Thickness +.08MM/.003"
	31431402	X	Valve Inlet	Thickness +.38MM/.015"
	31431403	X	Valve Inlet	Thickness +.76MM/.030"
10	31431881	4	Valve Exhaust	(1)
	31431882	X	Valve Exhaust	Thickness +.08MM/.003"
	31431883	X	Valve Exhaust	Thickness +.38MM/.015"
	31431884	X	Valve Exhaust	Thickness +.76MM/.030"
11	33152139	4	Insert	
12	33817117	8	Seal	(1)
	33817118	X	Seal	Thickness +.38MM/.015"
	33817119	X	Seal	Thickness +.76MM/.030"
13	31744131	8	Spring	(1)
14	31745121	8	Spring	(1)
15	33123117	8	Washer	(1)
16	33423122	8	Cap	(1)
17	33173108	8	Cotter	(1)
				(A)
18	33221316	2	Nut	
19	32181424	6	Screw	
20	32181425	12	Screw	
21	32181426	2	Screw	
22	36475706	1	Plate	
23	0746453	2	Setscrew	
24	0920054	2	Washer	
25	36177111	1	Plate	
26	0746453	2	Setscrew	
27	0920054	2	Washer	
28	37762705	1	Body	
29	2431154	1	Plug	
30	2485791	2	Pin	
31	36853514	1	Joint	
32	0826467	1	Stud	
33	0576051	1	Nut	
34	0920054	1	Washer	
35	0096434	2	Bolt	
36	0096439	1	Bolt	
37	0920054	3	Washer	
38	0746255	2	Setscrew	
39	0096238	1	Bolt	
40	0920053	3	Washer	
41	2485659	1	Thermostat	
42	37735651	1	Connection	
43	36862151	1	Joint	
44	0096433	2	Bolt	
45	0920054	2	Washer	

(A)
SERVICED IN PAIRS

3-0080-005-C

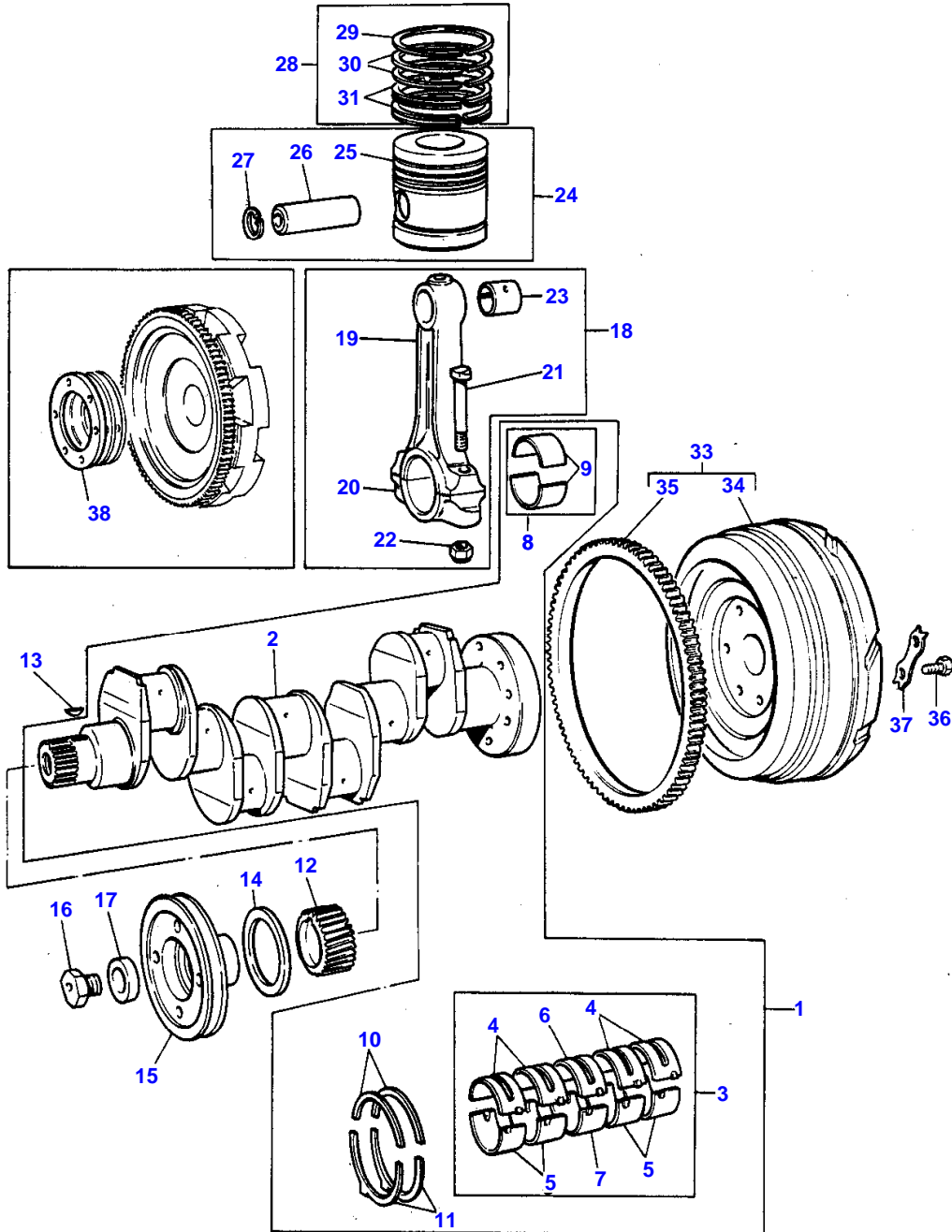

CRANKSHAFT - A4.236

Item	Part Number	Qty	Description	Comments
				A4.236
1	U5BG0019	1	Kit, Crankshaft	
2		1	Crankshaft	(1) Not serviced, order REF .1
3	81558	1	Kit, Bearing	(1) (A)
3	81558A	X	Kit, Bearing	(A) Thickness -.010" Thickness (-).25MM
3	81558B	X	Kit, Bearing	(A) Thickness -.020" Thickness (-).51MM
3	81558C	X	Kit, Bearing	(A) Thickness -.030" Thickness (-).76MM
4		4	Bearing	(3) (A,D)
5		X	Bearing	(3) (A,D)
6		X	Bearing	(3) (A,D)
7		X	Bearing	(3) (A,D)
8	85042	1	Kit, Bearing	(1) (A)
8	85042A	X	Kit, Bearing	(A) Thickness -.010" Thickness (-).25MM
8	85042B	X	Kit, Bearing	(A) Thickness -.020" Thickness (-).51MM
8	85042C	X	Kit, Bearing	(A) Thickness -.030" Thickness (-).76MM
9		2	Bearing	(8) (A,D)
10	31137311	2	Washer	(1)
	31137312	X	Thrust Washer	Thickness +.007" Thickness (+).18MM
11	31137321	2	Washer	(1)
	31137322	X	Thrust Washer	Thickness +.007" Thickness (+).18MM
12	31171681	1	Gear,Crankshaft	
13	0500012	1	Woodruff Key	
14	33125416	1	Washer	
15	31148711	1	Pulley	
16	32162318	1	Screw	
17	33125124	1	Washer	
18	M7BJ0015	4	Kit, Conrod	
19		1	Rod	(18) Not serviced, order REF 18
20		1	Cap	(18) Not serviced, order REF 18
21	32762116	2	Bolt	(18)
22	33221321	2	Nut	(18)
23	31134123	1	Bush	(18)
24	68300	4	Kit, Piston	(B,D)
	68301	4	Kit, Piston	(C,D)
	68300C	X	Kit, Piston	(B,D) Thickness .030" Thickness .76MM
24	68301C	X	Kit, Piston	(C,D) Thickness .030" Thickness .76MM
25		1	Piston	(24) (D)
26		1	Pin	(D)
27	0170002	2	Circlip	
28	41158041	4	Kit, Piston Ring	

MASSEY FERGUSON

MF 275 TRACTOR, ->| 221522 (GB) - 819669

819669

CRANKSHAFT - A4.236

8

Item	Part Number	Qty	Description	Comments
28	41158041C	X	Kit, Piston Ring	Thickness +.030" Thickness (+).76MM
29		1	Ring	(28) (D)
30		2	Ring	(28) (D)
31		2	Ring	(28) (D)
33	41117084	1	Flywheel	
34		1	Flywheel	(33) Not serviced, order REF.33
35	0410236	1	Starter Ring	(33)
36	2182122	6	Setscrew	
37	0921062	3	Tab Washer	
38		.	.	(E) (A) PRE-FINISHED (B) UNTOPPED (C) PRE-TOPPED (D) ORDER APPROPRIATE ASSEMBLY (E) NOT FITTED ON THIS APPLICATION

3-0085-005-A

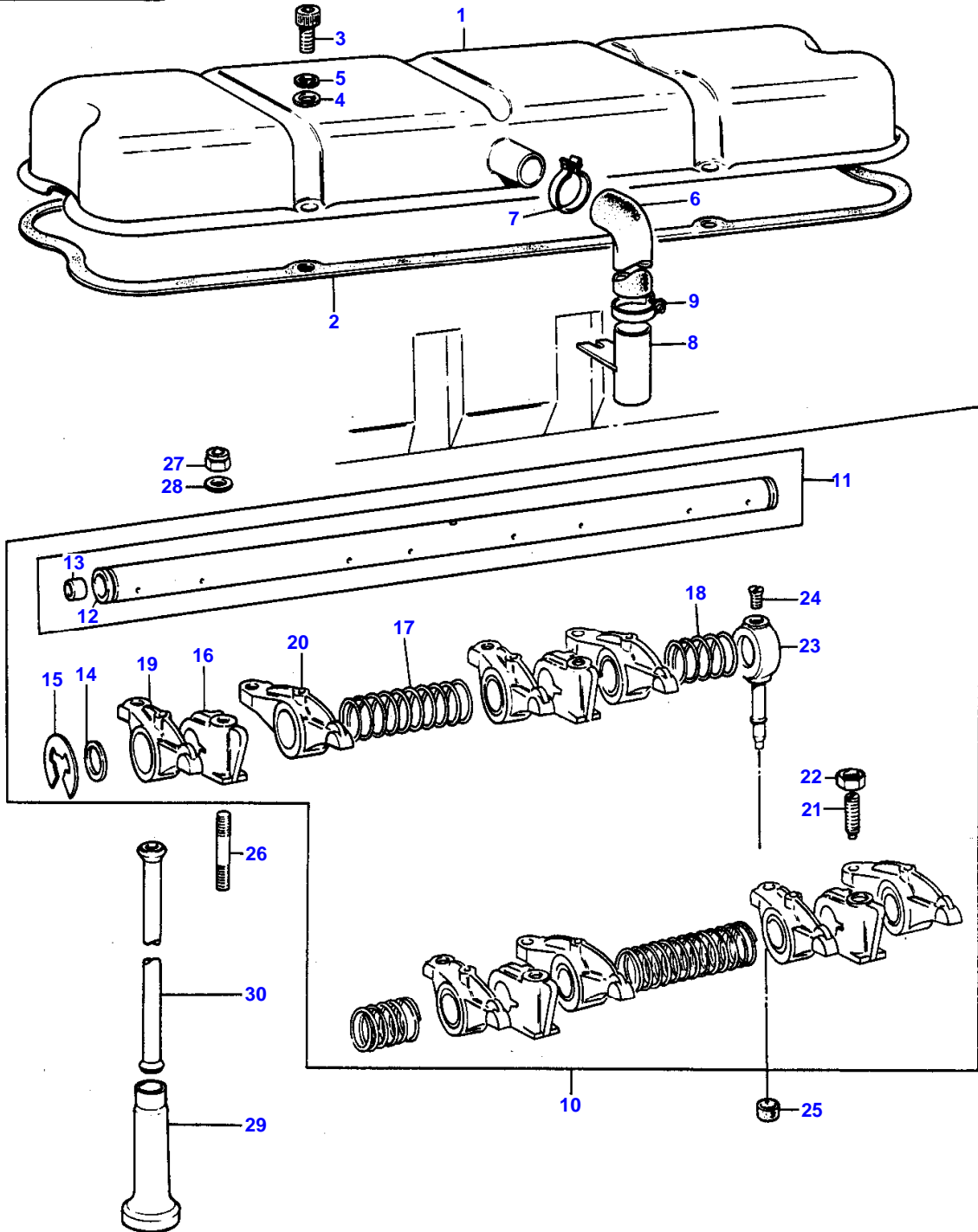

MASSEY FERGUSON**MF 275 TRACTOR, ->| 221522 (GB) - 819669****819669****CYLINDER HEAD COVER - A4.236****12**

Item	Part Number	Qty	Description	Comments
				A4.236
1	37188549	1	Cyl.Head Cover	
2	36811131	1	Joint	
3	2172513	4	Screw	
4	0920002	4	Washer	
5	0920052	4	Washer	
6	33872516	1	Pipe,Breather	
7	0180063	1	Clip	
8	35731144	1	Pipe,Breather	
9	0180063	1	Clip	
10	87144	1	Rocker Shaft Ass	
11	83449	1	Rocker Shaft	(10)
12		1	Shaft	(11) Not serviced, order 83449
13	0650507	2	Plug	(11)
14	33117415	2	Washer	(10)
15	0170151	2	Circlip	(10)
16	37521331	4	Bracket	(10)
17	31744123	2	Spring	(10)
18	31743108	2	Spring	(10)
19	37371281	4	Lever	(10)
20	37371271	4	Lever	(10)
21	0720579	8	Screw	(10)
22	0576052	8	Nut	(10)
23	35511111	1	Pipe	(10)
24	0726504	1	Setscrew	(10)
25	33811113	1	Olive	(10)
26	0826628	4	Stud	
27	2211284	4	Nut	
28	0920006	4	Washer	
29	31434163	8	Tappet	
30	31434307	8	Pushrod	

3-0305-002-B

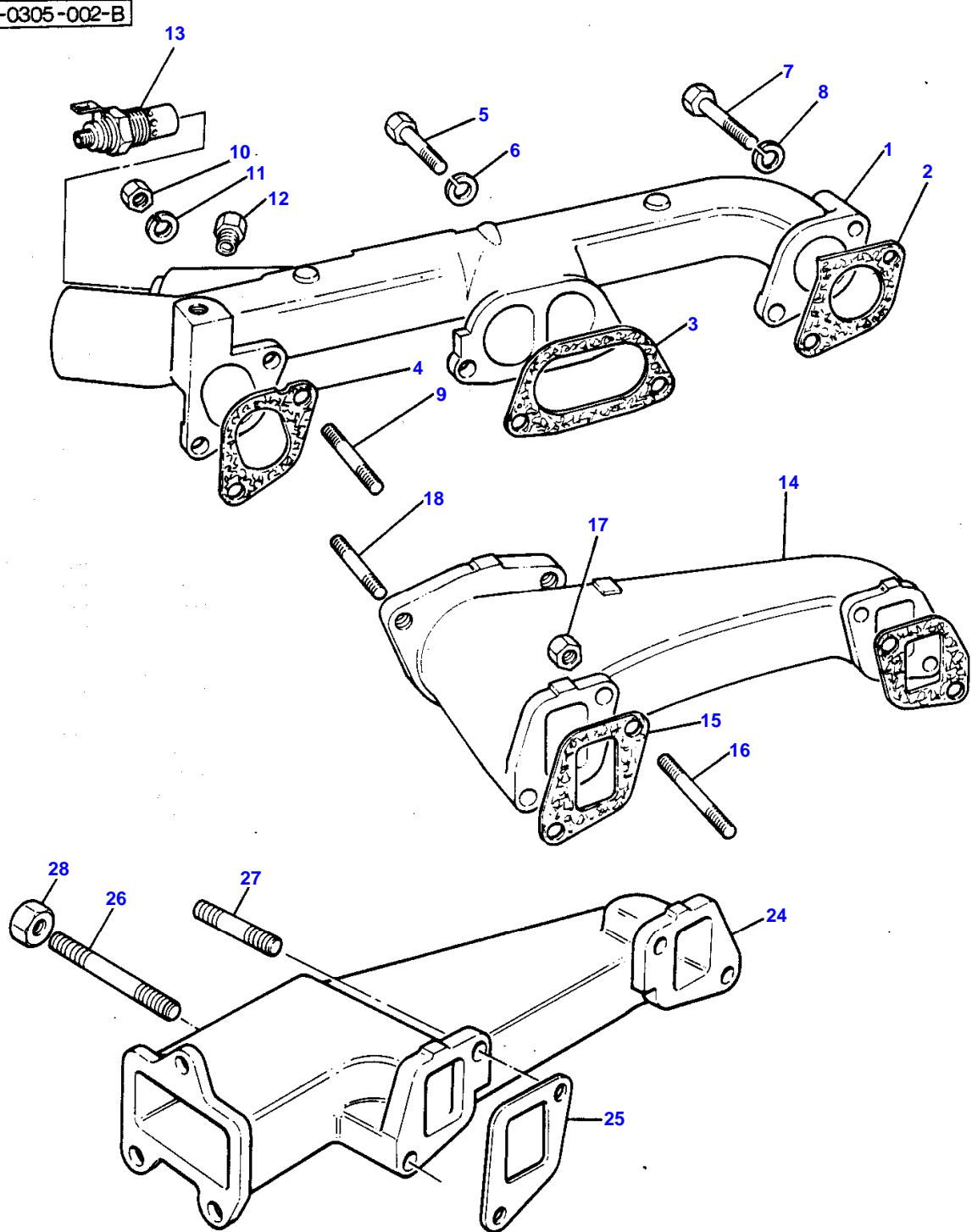

MASSEY FERGUSON**MF 275 TRACTOR, ->| 221522 (GB) - 819669****819669****AIR INDUCTION AND EXHAUST SYSTEM - A4.236 ENGINE****14**

Item	Part Number	Qty	Description	Comments
				A4.236 ENGINE
1	37787654	1	Induct.Manifold	
2	36862131	1	Joint	
3	36862133	1	Joint	
4	36866462	1	Joint	
5	0746424	4	Bolt	
6	0920054	4	Washer	
7	0096439	1	Bolt	
8	0920054	1	Washer	
9	0826481	1	Stud	
10	0576051	1	Nut	
11	0920054	1	Washer	
12	0650204	1	Plug	
13	2666108	1	Intake Heater	
14	37781781	1	Exhaust Manifold	
15	36862159	2	Joint	
16	0826439	4	Stud	
17	2188135	4	Nut	
18	0826404	3	Stud	
24	37781051	1	Exhaust Manifold	
25	36862159	2	Joint	
26	0826526	1	Stud	
27	0826403	3	Stud	
28	2188135	4	Nut	

Buy Now



Our support email:

ebooklibonline@outlook.com