

TABLE OF CONTENT

Page Title	Page Number
STRAW DIVIDER	1-1
KNIVES AND FINGERS	1-2
KNIFE CRANK AND BELLE CRANK	1-3
FEEDER DRUM	1-4
COUNTER SHAFT	1-5
GUARDING AND REDUCING EQUIPMENT	1-6
WEARING PLATES AND STONE STOP	1-7
TABLE TRAILER 1	1-8
TABLE TRAILER 2	1-9
LIGHTENING BRACKET	1-10
REVERSE DRIVE OF CUTTING TABLE	1-11
SIDE KNIFE	1-12
REEL - 14'	2-1A
REEL - 16'-18'	2-1B
REEL SUSPENSION AND ECCENTRIC	2-2
REEL SUSPENSION AND HYDRAULIC CYLINDERS	2-3
REEL SUSPENSION AND HYDRAULIC MOTOR	2-4
FEEDER SHAFT, LOWER	3-1
FEEDER SHAFT, UPPER WITH SUSPENSION	3-2
FEEDER CHAIN - PROTECTIVE PLATES	3-3
TABLE CLUTCH (F.39541)	3-4
TABLE CLUTCH (T.39540)	3-5
GUARDING	3-6
HYDRAULIC CYLINDER - EL - CYLINDER	3-7
CONCAVE	4-1
CONCAVE SETTING	4-2
THRESHING DRUM (F. ENGINE TYPE 611DSL. + PERK. 170HP)	4-3A
THRESHING DRUM (FOR PERKINS 153 HP)	4-3B
DRUM SELECTOR (F. ENGINE TYPE 611DSL + PERK. 170 HP)	4-4
DRUM SELECTOR (FOR PERKINS 153 HP)	4-5
STONE TRAP	4-6
DRUM COVER	4-7
STRIPPER BEATER WITH PULLEYS (F.40975)	4-8A
STRIPPER BEATER WITH PULLEYS (T.40974)	4-8B
CHECK FLAPS	4-9
STRAW WALKER AND CRANKS	5-1
MAIN FAN WITH BOTTOM PLATE AND SHUTTER	6-1
GUARDING AT MAIN FAN - ACCUMULATOR	6-2
MAIN FAN BLADES, GRAIN AUGER AND RETURN AUGER	6-3
MAIN FAN SELECTOR	6-4
CONVEYOR PAN WITH SUSPENSION	6-5
CLEANING UNIT DRIVE	6-6
CLEANING UNIT, SIEVES	6-7
CLEANING UNIT WITH SUSPENSION	6-8
GRAIN ELEVATOR WITH TOP PART	7-1
GRAIN ELEVATOR WITH CHAIN AND BOTTOM PART	7-2
FILLING ELEVATOR WITH TOP PART	7-3
FILLING ELEVATOR WITH CHAIN AND BOTTOM PART	7-4
RETURN ELEVATOR	7-5
UPPER RETURN AUGER	7-6
SECOND CLEANER WITH FAN	8-1
CLEANER WITH FAN SHAFT AND BELT DRIVE	8-2
SECOND CLEANER WITH AWNER	8-3
SECOND CLEANER WITH CIRCULATION AND SUSP. STAY	8-4
SEED GRINDER	8-5
DISCHARGE AUGER, FIXED PART	9-1
SPREADER AUGER	9-2
DISCHARGE AUGER, SWIVEL PART - VIBRATION BEAM	9-3
DISCHARGE AUGER PIPE	9-4
SHUTTERS FOR GRAIN TANK - ROTORLAMP	9-5
GRAIN TANK TOP	9-6
SUCTION CHANNEL AND HYDRAULIC COOLER-PERKINS	10-1
RADIATOR HOSES AND CABLES-PERKINS	10-2
AIR CLEANER (PERKINS - F.42854)	10-3A
AIR CLEANER (PERKINS - T.42853)	10-3B
STRAINER-PERKINS	10-4

TABLE OF CONTENT

SILENCER AND HOSES-PERKINS	10-5
ENGINE BRACKET, FRONT - PROPULSION PUMP (PERKINS)	10-6
P.T.O. AND COUPLING AF THRESHING MECHANISM (PERKINS)	10-7
ENGINE BRACKET, REAR - HYDR. PUMP (PERKINS)	10-8
FUEL TANK (PERKINS + VALMET)	10-9
OIL TANK - FRAME F. ENGINE COMPARTMENT (PERK. F.42854)	10-10A
OIL TANK - FRAME F. ENGINE COMPARTMENT (PERK. - T.42853)	10-10B
SUCTION CHANNEL AND HYDR. COOLER (VALMET)	10-11
RADIATOR HOSES AND CABLES (VALMET)	10-12
AIR CLEANER (VALMET) (F.42854)	10-13A
AIR CLEANER (VALMET) (T.42853)	10-13B
STRAINER AND RADIATOR BRACKET (VALMET)	10-14
PROP. PUMP - COUPL. OF THRESH. MECHAN. (VALMET).	10-15
ENGINE BRACKET AND SILENCER (VALMET)	10-16
P.T.O. AND HYDRAULIC PUMP (VALMET)	10-17
FRAME F. ENGINE COMPARTMENT (VALMET) (F.42854)	10-18A
FRAME F. ENGINE COMPARTMENT (VALMET) (T.42853)	10-18B
COUNTER SHAFT WITH SELECTOR	11-1
COUNTER DRIVE FOR CLEANING UNIT AND SHAKERS	11-2
BELT MOUNTING	11-3
DRIVING WHEELS AND SIDE PINIONS ON THE RIGHT	12-1
DRIVING WHEELS AND SIDE PINIONS ON THE LEFT	12-2
FRONT AXLE WITH GEARBOX AND SHAFTS	12-3
REAR AXLE	12-4
STEERING WHEEL AND STEERING CYLINDER	12-5
GEAR BOX 1, ZF	12-6
GEAR BOX 2, ZF	12-7
GEAR BOX 3, ZF	12-8
SIDE PINIONS ZF	12-9
GEAR BOX 2 GEARS, COBRA	12-10
GEAR BOX 2 GEARS, COBRA	12-11
GEAR BOX 3 GEARS F.48199	12-12
GEAR BOX 3 GEARS F.48199	12-13
SIDE PINIONS COBRA F.45798-T.45802 AND F.47493	12-14
LADDER RAILS	13-1
BOTTOM PLATES - PLATFORM, RIGHT	13-2
BRAKE PEDALS AND BRAKE CABLES	13-3
OPERATOR SEAT, STEERING ARRANGEMENT	13-4
INSTRUMENT PANEL WITH SWITCHES AND CABLES	13-5
ADJUSTING LEVERS	13-6
CONTROL BOX 1	13-7
CONTROL BOX 2	13-8
CAB ROOF	13-9
CAB ROOF WITH AIR-CONDITION	13-10
DRIVER CABIN	13-11
WINDOW PANES	13-12
HYDRAULIC CYLINDER - STEERING CYLINDER 1	14-1A
HYDRAULIC CYLINDER - STEERING CYLINDER 2	14-1B
PROPULSION HYDRAULIC	14-2
AUXILIARY HYDRAULIC (F.39980)	14-3
AUXILIARY HYDRAULIC (T.39540)	14-4
HYDRAULIC FOR VIBRATION BEAM	14-5
HYDRAULIC CHART, REVERSE DRIVE	14-6
HYDRAULIC - TABLE F.39980	14-7
PROPULSION HYDRAULIC SAUER	14-8
BAND	15-1
STRAW NOSE - LADDER	15-2
UPPER GUARDING	15-3
LOWER GUARDING AND WIND GUARDING	15-4
CONDENSER	15-5
TOOLS - PAINT	16-1
WIRING - TABLE TRAILER	16-4
WIRING - UNI-CONTROL	16-5
WIRING - GRAIN LOSS MONITOR	16-6
STRAW CHOPPER 1	17-1
COUNTER DRIVE FOR STRAW CHOPPER	17-2
STRAW CHOPPER SUSPENSION	17-3
STRAW CHOPPER REKORD	17-4

TABLE OF CONTENT

ACCESSORIES REKORD	17-5
STRAW CHOPPER FLAP SYSTEM CHOPPER	17-6
DISTRIBUTOR BOX FLAP SYSTEM CHOPPER	17-7A
DISTRIBUTOR BOX FLAP SYSTEM CHOPPER	17-7B
STRAW CHOPPER 2	17-8A
STRAW CHOPPER 2	17-8B
SPREADER HOOD	17-9
TRANSMISSION 1	18-1
TRANSMISSION 2	18-2

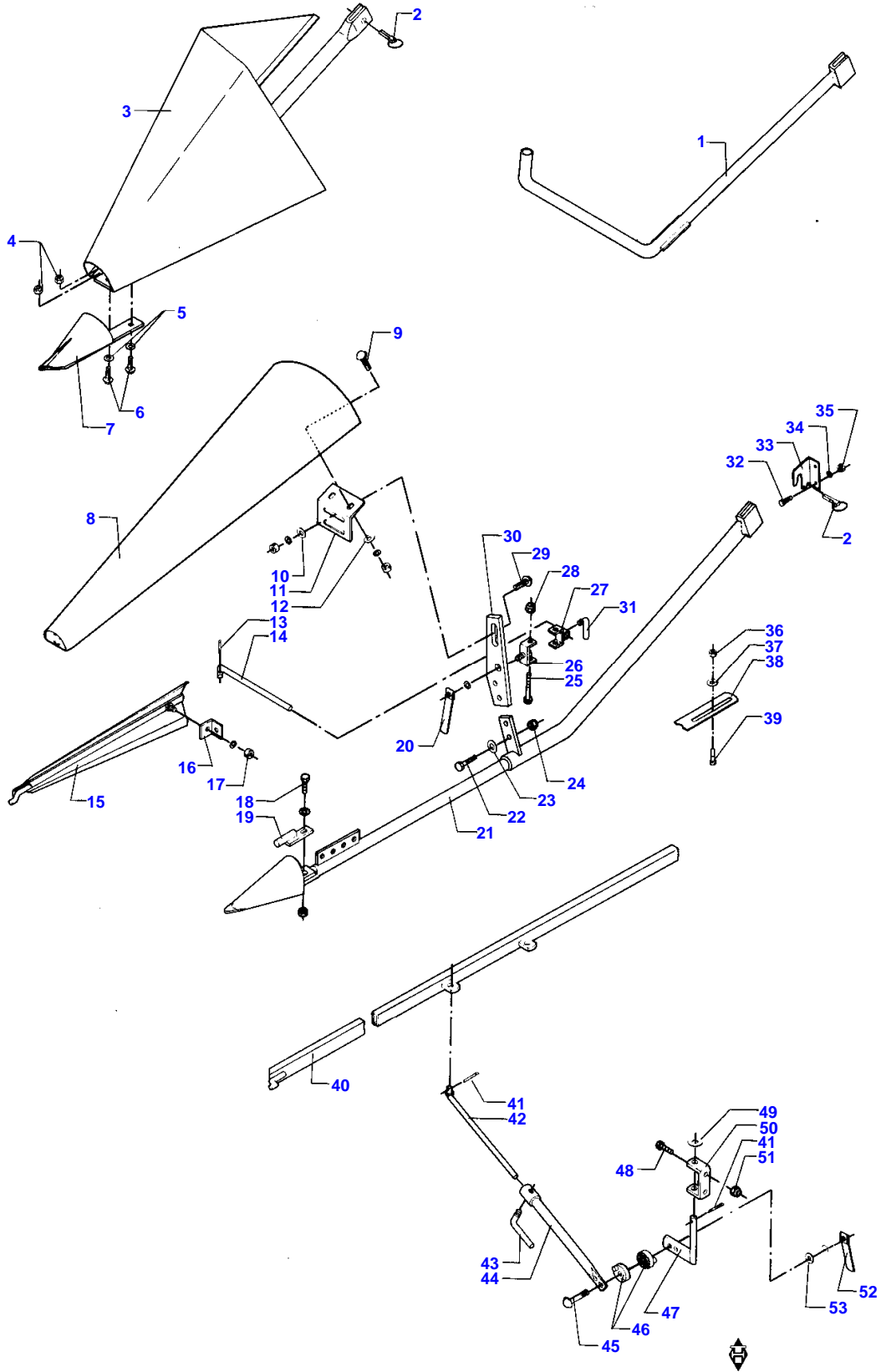

STRAW DIVIDER

Item	Part Number	Qty	Description	Comments
1	D28230460	2	Divider	
2	D41447300	2	Split Ring	
3	D28251801	1	Point	POS. 2 - 7
	D28251802	1	Point	POS. 2 - 7
4	D41087600	4	Locknut	
5	D20400471	4	Washer	
6	D40066800	4	Screw Metric	
7	D28260226	2	Point	
	D28251622	1	Divider	(F0) POS. 8 - 31 Right Hand
	D28251623	1	Divider	(F1) POS. 8 - 31 Left Hand
8	D28211126	1	Divider	
9	D40063700	2	Screw	
10	D20400471	2	Washer	
11	D28230447	1	Plate	
12	D20400409	2	Washer	
13	D41408700	1	SPLIT PIN	
14	D28230462	1	Rod	
15	D28230457	1	Wing	
16	D27200313	1	Angle	
17	D41010800	1	Nut Metric	
18	D40407900	1	Screw Metric	
19	D27200640	1	Stop	
20	D27300323	1	Locknut	
21	D28230517	1	Support	
22	D40405000	2	Screw Metric	
23	D20400409	2	Washer	
24	D41013500	2	Nut	
	D28230467	1	Mounting	POS. 25 -28
25	D40424400	1	HEXAGON SCREW	
26	D28230468	1	Mounting	
27	D28230471	2	Mounting	
28	D41087500	1	Locknut	
29	D40066700	2	Screw	
30	D28250549	1	Plate	
31	D27200300	1	Pin	
32	D40407700	4	Screw	
33	D28230465	1	Support	Right Hand
	D28230466	1	Support	Left Hand
34	D20400471	4	Washer	
35	D41087600	4	Locknut	
36	D41087700	2	Locknut	
37	D20400426	2	Washer	
38	D28230453	2	Plate	
39	D40070200	2	Screw Metric	
	D28230487	2	Wing	POS. 40 - 53
40	D28230480	1	Wing	
41	D41410600	2	SPLIT PIN	
42	D28230482	1	Support	
43	D27200364	1	Handle	
44	D28230486	1	Pipe	
45	D40021300	1	Screw	
46	D28230488	2	Clutch	
47	D28230473	1	Support	
48	D40407700	2	Screw	
49	D20400518	1	Spacer	
50	D28230472	1	Bracket	
51	D41087600	2	Locknut	
52	D27300323	1	Locknut	
53	D20400426	1	Washer	(F0) ON THE RIGHT (F1) ON THE LEFT

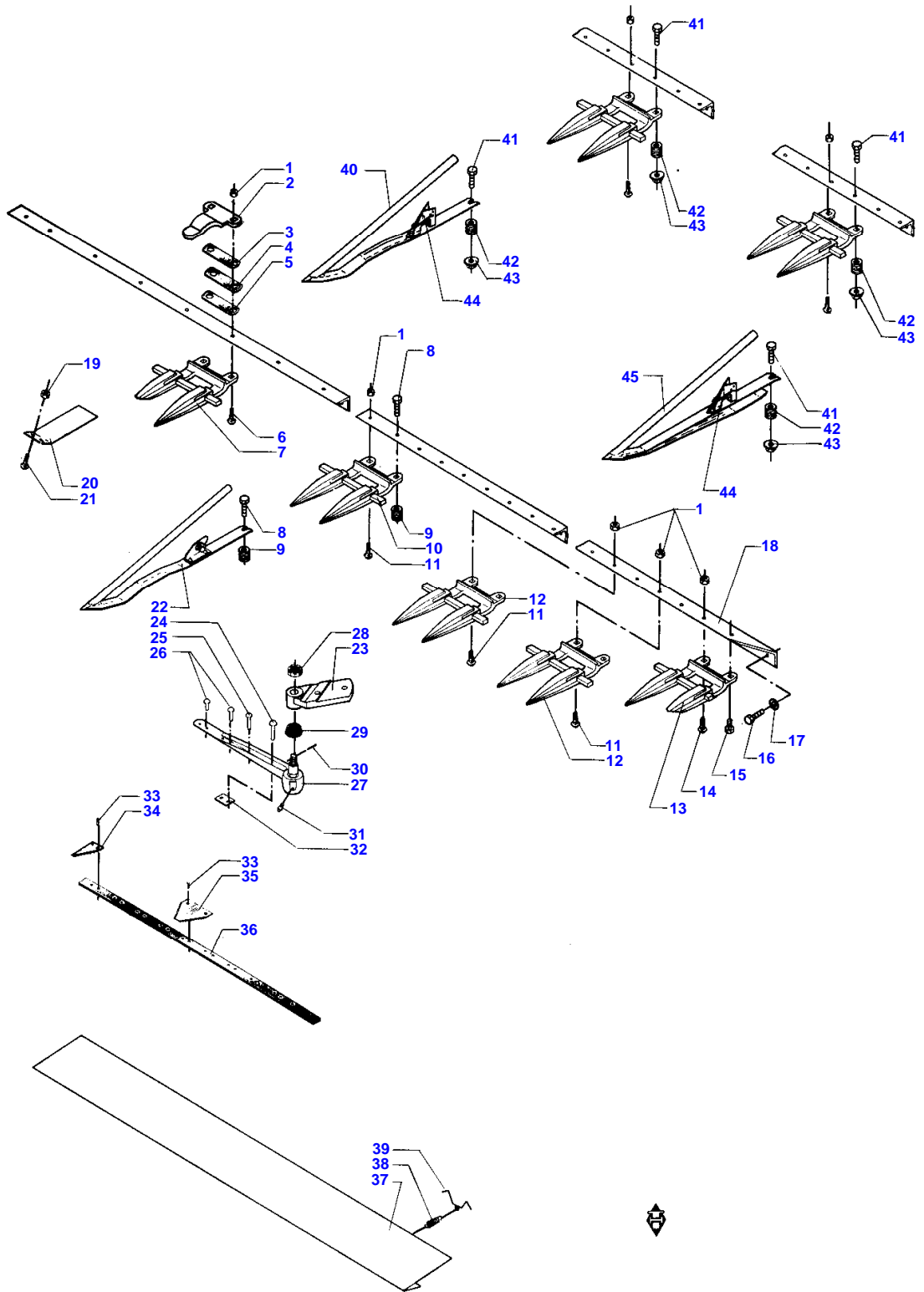

KNIVES AND FINGERS

Item	Part Number	Qty	Description	Comments
1	D41010800		Nut Metric	
2	D25200899	14	Clip	14'-4,34M
	D25200899	16	Clip	16'-4,95M
	D25200899	18	Clip	18'-5,56M
3	D28210349		Shim	
4	D28210350		Shim	
5	D28230292		Shim	
6	D40551600		Bolt	
7	D28260531	1	Finger	
8	D40425800		Screw	
9	D28230833		Nut	
10	D44102900	25	Finger	14'-4,43M
	D44102900	31	Finger	16'-4,95M
	D44102900	35	Finger	18'-5,56M
11	D40551600		Bolt	
12	D28280821	2	Finger	
13	D44104400	1	Finger	+F.46080
14	D40551500		Bolt	
15	D40407600	1	Screw	
16	D40407800		HEXAGON SCREW	
17	D20400471		Washer	
18	D28230011	1	Bar	14'
	D28230010	1	Bar	16'
	D28230009	1	Bar	18'
19	D41013500	2	Nut	
20	D28230829	1	Guard	
21	D40063700	2	Screw	
22	D49040000	14	Ear Lifter	14'-4,34M
	D49040000	16	Ear Lifter	16'-4,95M
	D49040000	18	Ear Lifter	18'-5,56M
23	D28230227	2	Lever	
	D28230034	1	Blade	14'
				POS. 24 - 36 4,34M
	D28230037	1	Knife	16'
				POS. 24 - 36 4,95M
	D28230040	1	Knife	18'
				POS. 24 - 36 5,56M
24	D41378300	3	Rivet	
25	D41377800	2	Rivet	
26	D41378200	4	Rivet	
27	D44120000	1	Knife Head	POS, 28 - 29
28	D41048700	1	Castle Nut	
29	D44120200	1	Cap	
30	D41406000	1	SPLIT PIN	
31	D43004900	1	Foam	
32	D28230120	1	Spacer	
33	D41377500		Rivet	
34	D44103400	1	Blade	
35	D44100000		Section	
36	D28230008	1	Knife Back	14'-4,34M
	D28230007	1	Knife Back	16'-4,95M
	D28230006	1	Knife Back	18'-5,56M
39	D28230842	1	Guard	(T7) POS. 38 - 39
37	D28230843	1	Guard	(T7) POS. 38 - 39
37	D28230844	1	Guard	(S4) POS. 38 - 39
37	D28230845	1	Guard	(S4) POS. 38 - 39
37	D28230842	2	Guard	(T8) POS. 38 - 39
38	D26500317	2	Spring	
39	D28230841	2	Spring	
40	D49040200	14	Ear Lifter	(3) 14' 4,36M
40	D49040200	16	Ear Lifter	(3)

KNIVES AND FINGERS

Item	Part Number	Qty	Description	Comments
40	D49040200	18	Ear Lifter	16' 4,95M (3)
41	D40426100		Screw	18' 5,56M TYPE 2 + 3
42	D49040500		Roller	TYPE 2 + 3
43	D41013600		Nut	
44	D49040400		Spring	TYPE 2 + 3
45	D49040300	14	Ear Lifter	(3) 14' 4,36M
45	D49040300	16	Ear Lifter	(3) 16' 4,95M
45	D49040300	18	Ear Lifter	(3) 18' 5,56M (S4) 16' (T7) 14' (T8) 18' (3) OPTIONAL EQUIPMENT



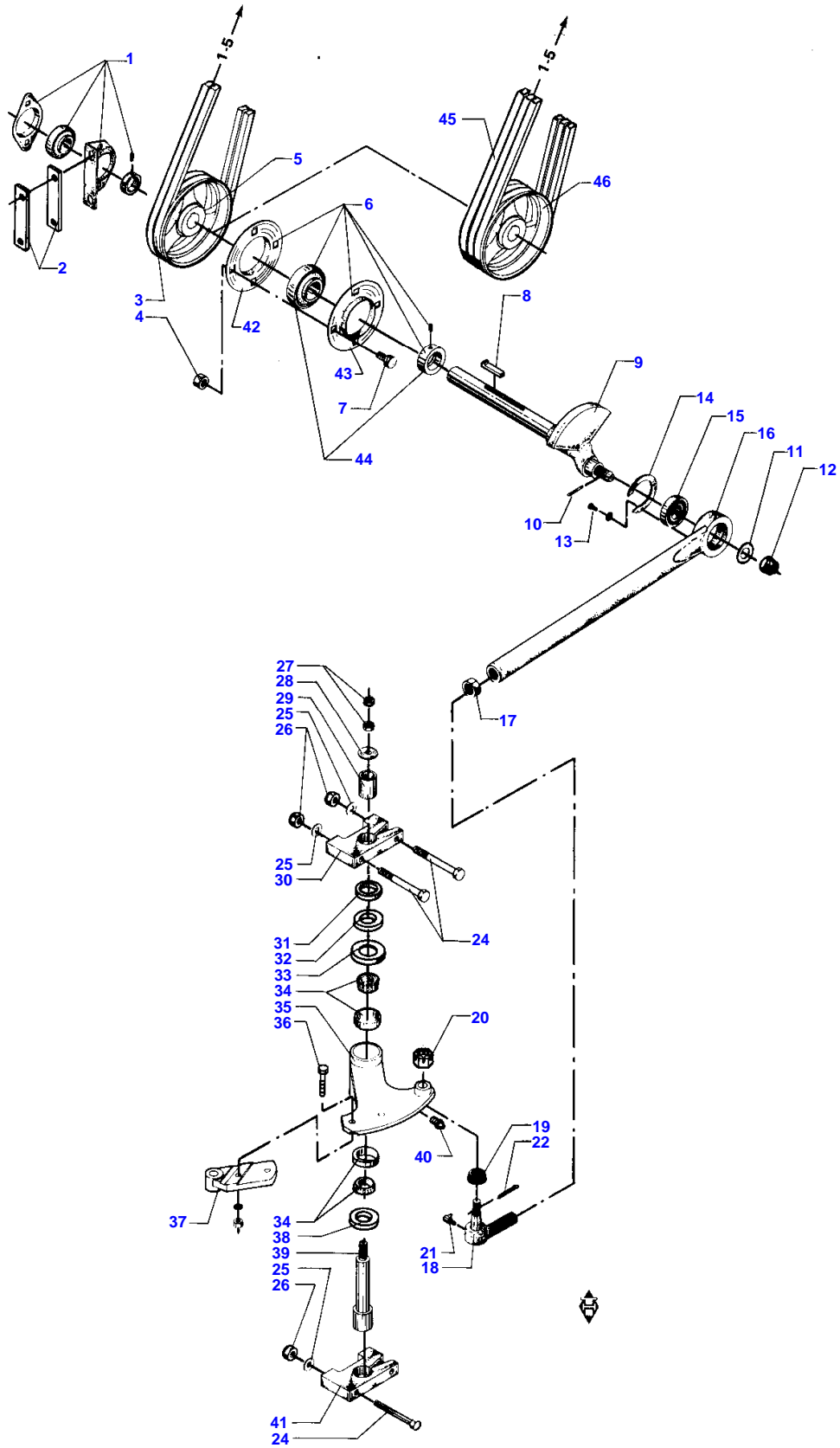

KNIFE CRANK AND BELLE CRANK

Item	Part Number	Qty	Description	Comments
1	D41707300	1	Bearing	
2	D28211109	2	Shim	
3	D41964300	2	V Belt	(V7)
4	D41087700	4	Locknut	
5	D28250704	1	Pulley	(V7)
6	D41707900	1	Flange	(V7)
7	D40410800	4	HEXAGON SCREW	
8	D43155200	1	Gib Key	(V7)
9	D28250169	1	Arm	(T7)
	D28240124	1	Crankshaft	(T8)
10	D41409100	1	SPLIT PIN	
11	D20400448	1	Washer	
12	D41049100	1	Castle Nut	
	D28230249	1	Pitman	POS. 13 - 21
13	D40402200	3	Screw Metric	
14	D28220084	1	Lock Washer	
15	D41706100	1	Bearing Ball	
16	D28230247	1	Conrod	
17	D28220093	1	Locknut	
18	D44120100	1	Toggle	POS. 19 - 20
19	D44120200	1	Cap	
20	D41048700	1	Castle Nut	
21	D43005100	1	Greaser	
22	D41409000	1	Pin	
24	D40429800	4	HEXAGON SCREW	
25	D20400426	1	Washer	
26	D41087700	1	Locknut	
	D28230231	1	Bellcrank	POS. 27 - 40
27	D41012300	2	HEXAGON SCREW	
28	D28220087	1	Washer	
29	D28250691	1	Bush	
30	D28210913	1	Clamp	
31	D28250690	1	Spacer	
32	D45409100	1	Seal	
33	D28250692	1	Ring	
34	D41667400	2	Bearing Roller	
35	D28230224	1	Crank	
36	D40428300	2	HEXAGON SCREW	
37	D28230227	1	Lever	
38	D45409000	1	Seal	
39	D28220086	1	Shaft	M16
40	D43001500	1	Greaser	
41	D28210913	1	Clamp	
42	D41714700	1	Flange	(T8)
43	D41705600	1	Flange	(T8)
44	D41663700	1	Bearing	(T8)
45	D41963900	3	Belt	(T8)
46	D28250705	1	Pulley	(T8)
				18'
				(V7)
				14' - 16'

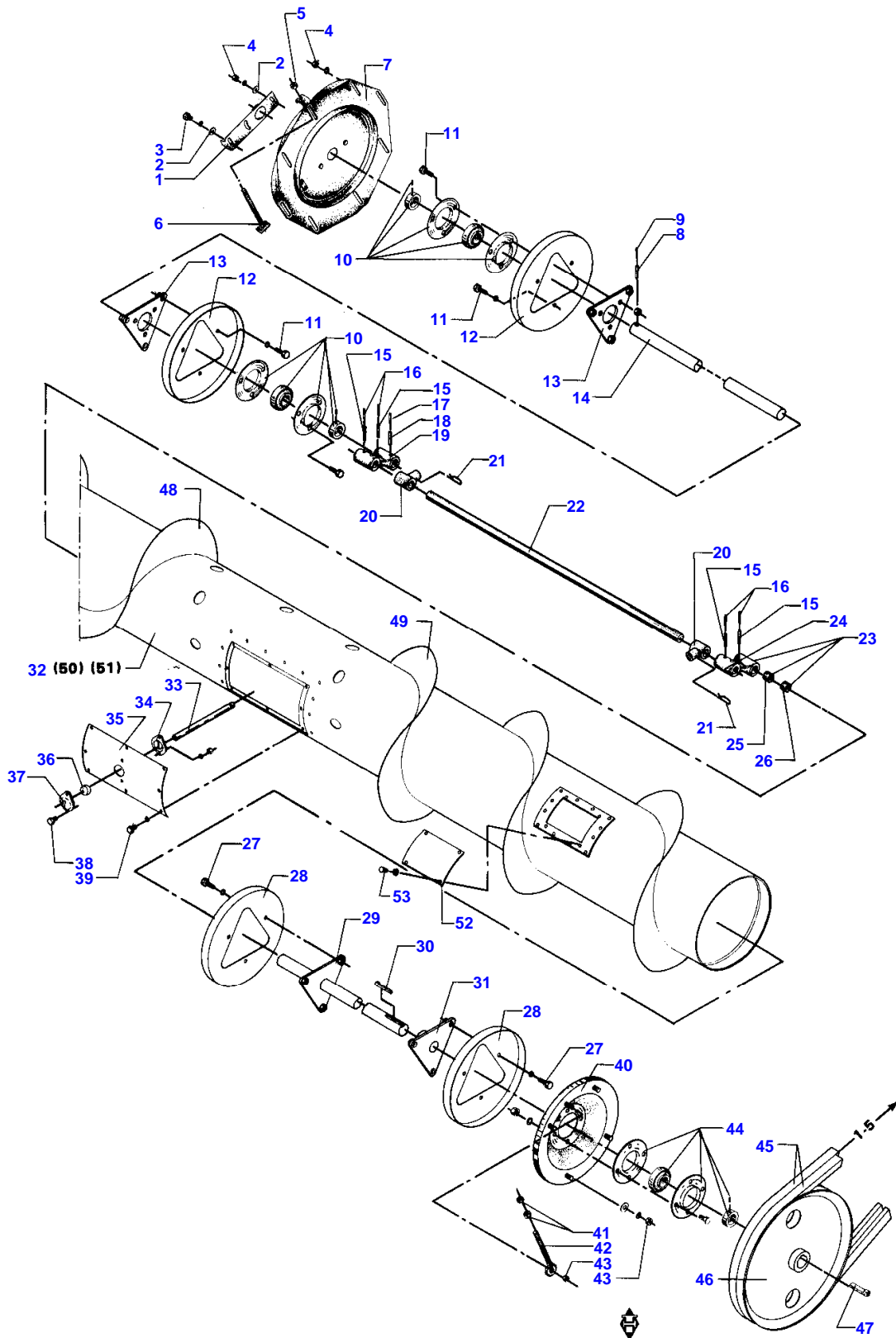

FEEDER DRUM

Item	Part Number	Qty	Description	Comments
1	D28250111	1	Bracket	
2	D20400409		Washer	
3	D40404700	1	Screw Metric	
4	D41013500	2	Nut	
5	D41010800	1	Nut Metric	
6	D28211023	1	Bolt	
7	D28251319	1	Plate	Right Hand F.915608
	D28220110	1	Plate	T.915607
8	D42625300	1	Pin	
9	D42616400	1	Pin	
	D28250381	1	Shaft	POS. 10 - 26
	D28250382	1	Shaft	POS. 10 - 26
	D28250930	1	Shaft	POS. 10 - 26
10	D41707800	2	Flange	
11	D40407700	12	Screw	
12	D28251405	2	Plate	+F.914863
13	D28250107	2	Plate	
14	D28250109	1	Shaft	14'
	D28250251	1	Crankshaft	16'
	D28250252	1	Crankshaft	18'
15	D42616200	4	Pin	
16	D42609900	4	Pin	
17	D42616400	1	Pin	
18	D42625300	1	Pin	
19	D28250385	1	Arm	Right Hand
20	D28250585	15	Support	
21	D28281236	12	Hair Pin	
22	D28200547	1	Shaft	
23	D28250384	1	Arm	(T7) POS. 23 - 26
23	D28230051	1	Arm	(T9) POS. 23 - 26
24	D28250096	1	Arm	Left Hand (T7)
24	D28230050	1	Arm	(T9) Left Hand
25	D43338100	1	Bearing	(T7)
	D43338700	1	Bush	(T9)
26	D43338300	1	Bush	(T7)
	D43338900	1	Bush	(T9)
27	D40407600	6	Screw	
28	D28251405	2	Plate	+F.914863
29	D28250101	1	Drive Shaft	14' POS. 30 - 31
29	D28250247	1	Drive Shaft	16' POS. 30 - 31
29	D28250248	1	Drive Shaft	18' POS. 30 - 31
30	D43154300	1	Gib Key	
31	D28250535	1	Flange	(T7)
	D28250536	1	Flange	16' - 18'
32	D28251363	1	Auger	(T7) POS. 10 - 31
32	D28251365	1	Auger	(S4) POS. 10 - 31
32	D28251367	1	Auger	(T8) POS. 10 - 31
33	D28250566	15	Finger	
34	D28200150	15	Support	
35	D28251302	1	Cover	F.915608
	D28200133	1	Cover	T.915607
36	D28260314	15	Toggle	
37	D28200151	15	Support	
38	D40402400	30	Screw Metric	
39	D40402200	8	Screw Metric	
40	D28210870	1	Plate	(T7)
	D28230103	1	Plate	(T9)
41	D41010800	2	Nut Metric	
42	D28210895	1	Bolt	
43	D41010700	5	Nut Metric	

FEEDER DRUM

Item	Part Number	Qty	Description	Comments
44	D41707800	1	Flange	(T7)
44	D41707900	1	Flange	(T9)
45	D41983500	2	V Belt	(R8) 14' - 16'
45	D41983600	2	Belt	(R8) 18'
45	D41983500	1	V Belt	(R9) 14' - 16'
45	D41983600	2	Belt	(T5) 14' - 16'
46	D28250887	1	Pulley	(R8) 14'
46	D28230198	1	Pulley	(R8) 16' - 18'
46	D28250887	1	Pulley	(R9)
47	D43155200	1	Gib Key	(T7)
47	D43156800	1	Gib Key	(T9)
48	D28251332	1	Spiral	(T7)
48	D28251333	1	Spiral	(S4)
48	D28251334	1	Spiral	(T8)
49	D28251329	1	Spiral	(T7)
49	D28251330	1	Spiral	(S4)
49	D28251331	1	Spiral	(T8)
50	D28251303	1	Tube	
51	D28251337	2	Tube	(T7) 14'
51	D28251342	2	Shell	(S4)
51	D28251341	2	Shell	(T8)
52	D28250412	2	Cover	(T9)
53	D40402200	8	Screw Metric	(R8) FOR TABLES WITH DOUBLE BELT (R9) FOR TABLES WITH SINGLE BELT (S4) 16' (T5) ONLY FOR DRY LANDS (T7) 14' (T8) 18' (T9) 16' - 18'

**Buy Now**



Our support email:

[ebooklibonline@outlook.com](mailto:ebooklibonline@outlook.com)