

Page Title	Page Number
SECTION DIVIDER	1
ENGINE INSTALLATION	2
CYLINDER BLOCK - A4.248 ENGINE	3
CRANKSHAFT, PISTONS AND CONNECTING RODS - A4.248 ENGINE	4
CYLINDER HEAD - A4.248 ENGINE	5
ROCKER SHAFT - A4.248 ENGINE	6
TIMING GEAR AND CAMSHAFT - A4.248 ENGINE	7
BALANCER UNIT - A4.248 ENGINE	8
FUEL INJECTION EQUIPMENT (DIESEL) - A4.248 ENGINE	9
LUBRICATING OIL SUMP - A4.248 ENGINE	10
LUBRICATING OIL FILTER AND INTEGRAL COOLER - A4.248 ENGINE	11
WATER PUMP, THERMOSTAT AND HEAT EXCHANGER - A4.248 ENGINE	12
FUEL OIL LIFT PUMP - A4.248 ENGINE	13
AIR INDUCTION AND EXHAUST SYSTEM - A4.248 ENGINE	14
ALTERNATOR POSITIONER - A4.248 ENGINE	15
JOINTS AND GASKETS - A4.248 ENGINE	16
BATTERIES AND CABLES - TRACTORS WITH CAB - DOUBLE BATTERY	17
COOLING SYSTEM	18
AIR CONDITIONER	19
AIR CONDITIONER - COMPRESSOR	20
FUEL SYSTEM-FUEL TANK AND ATTACHMENTS	21
FUEL SYSTEM-FUEL FILTERS AND PIPES	22
FUEL SYSTEM-FUEL FILTER	23
AIR FILTER-DRY - DUAL ELEMENT - AIR INTAKE - OVER BONNET	24
EXHAUST SYSTEM-VERTICAL	25
THROTTLE CONTROLS	26
CONSOLE ELECTRICS-CAB MODELS	27
INSTRUMENT PANEL AND INSTRUMENTS - WITH CAB UP TO B18008 - FOOTSTEP UP TO A29150	28
CLUTCH-PEDAL	29
CLUTCH-SPLIT TORQUE CERAMETALLIC - 12/305MM PITCH CIRCLE DIAMETER	30
12 SPEED SYNCHROMESH SHUTTLE TRANSMISSION-HOUSING	31
12 SPEED SYNCHROMESH SHUTTLE TRANSMISSION-FORK AND GEARSHIFT RAIL	32
12 SPEED SYNCHROMESH SHUTTLE TRANSMISSION-INPUT SHAFT	33
12 SPEED SYNCHROMESH SHUTTLE TRANSMISSION-MAIN SHAFT	34
TOP COVER-12 SPEED CREEPER SHUTTLE TRANS - CABLE CONTROL	35
TOP COVER-12 SPEED CREEPER SHUTTLE TRANS - DRIVE GEAR BOX	36
TOP COVER-12 SPEED CREEPER SHUTTLE TRANS - CONTROL	37
SHIFT LEVERS-12 SPEED SYNCHRO SHUTTLE TRANS	38
SHIFT LEVERS-12 SPEED SYNCHRO SHUTTLE TRANS	39
4 WHEEL DRIVE CONTROLS	40
RANGEBOX-4 WHEEL DRIVE	41
RANGEBOX-4 WHEEL DRIVE POD	42
BOLTING ARRANGEMENT-CENTRE HOUSING TO TRANS. CASE	43
DRIVE SHAFT-CENTRE HOUSING TO TRANS. CASE	44
REAR AXLE-CENTRE HOUSING	45
REAR AXLE-SIDE COVER MK3A HYDRAULICS	46
REAR AXLE-SIDE COVER -IPTO - WITH 2 SPEED SHIFTABLE IPTO - UP TO SERIAL B49391	47
REAR AXLE-PTO DRIVE MECHANISM-TWO SPEED - 2 SPEED SHIFTABLE IPTO WITH HIGH FLOW PUMP	48
REAR AXLE-IPTO CLUTCH AND VALVES - WITH 2 SPEED SHIFTABLE IPTO	49
REAR AXLE-DIFFERENTIAL - WITH 2 SPEED SHIFTABLE IPTO	50
REAR AXLE-DIFFERENTIAL LOCK MECHANISM	51

TABLE OF CONTENT

REAR AXLE DIFFERENTIAL LOCK MECHANISM	51
REAR AXLE-HOUSING	52
DIFFERENTIAL LOCK CONTROLS	53
PTO CONTROLS	54
DIPSTICK	55
BRAKES-DISC BRAKES	56
BRAKES-SLAVE CYLINDER	57
BRAKES-HYDRAULIC PIPES	58
BRAKES-MASTER CYLINDER	59
BRAKES-MASTER CYLINDER	60
BRAKES-PEDALS	61
BRAKES-HANDBRAKE	62
REAR WHEELS-SQUARE DISC	63
FRONT WHEELS-4 WHEEL DRIVE	64
FRONT AXLE 4 WHEEL DRIVE-INSTALLATION	65
DRIVE SHAFT-4 WHEEL DRIVE	66
FRONT AXLE 4 WHEEL DRIVE-HOUSING	67
FRONT AXLE 4 WHEEL DRIVE-DIFFERENTIAL	68
FRONT AXLE 4 WHEEL DRIVE-STEERING	69
FRONT AXLE 4 WHEEL DRIVE-STEERING CYLINDERS	70
FRONT AXLE 4 WHEEL DRIVE-FINAL DRIVE	71
STEERING-STEERING WHEEL AND COLUMN - ADJUSTABLE STEERING - TRACTORS WITH CAB	72
STEERING ORBITROL UNIT	73
STEERING AUXILIARY HYDRAULIC LINES - TANDEM PUMP	74
STEERING TANDEM PUMP - SUNDSTRAND HYDRATEC	75
STEERING TANDEM PUMP - BOSCH	76
OIL COOLER-IPTO - WITH HYDROLOCK	77
HYDRAULIC LIFT PUMP-PUMP	78
HYDRAULIC LIFT PUMP-STRAINER UNIT	79
HYDRAULIC LIFT-LIFT COVER	80
HYDRAULIC LIFT-LIFT ARMS	81
HYDRAULIC LIFT-QUADRANT SUPPORT	82
REAR CONTROLS-SIDE CONSOLE	83
REAR CONTROLS-RESPONSE - EXTERNAL CONTROL	84
REAR CONTROLS-RESPONSE	85
SPOOL VALVE-SPOOL VALVE INSTALLATION	86
MALE COUPLER	87
SPOOL VALVE-VALVE	88
SPOOL VALVE-CONTROLS AND SUPPORT	89
SPOOL VALVE-PIPES AND FITTINGS - COMBINED FLOW	90
SELECTOR VALVE MK3A-VALVE	91
TRAILER BRAKES-TRAILER BRAKE VALVE INSTALLATION	92
TRAILER BRAKES-VALVE - SAFETY VALVE	93
FRONT HITCH	94
TOP LINKS-STOWAGE HOOK	95
LINKAGE-LOWER LINKS CAT 1 AND 2 - STANDARD	96
STABILISER-CHAIN	97
SHEET METAL-GRILLE	98
SHEET METAL-HOOD	99
BULKHEAD	100
GUARD-PTO	101
TOOL BOX	102
EMBLEMS	103
DECALS-ENGLISH	104

TABLE OF CONTENT

DECALS-ENGLISH	105
TRACTOR CAB-MOUNTS	106
TRACTOR CAB-HEATER	107
TRACTOR CAB-HEATER	108
TRACTOR CAB-HEATER HOSES	109
TRACTOR CAB-FRAME	110
STEP PLATE	111
TRACTOR CAB-DOORS	112
TRACTOR CAB-WINDOWS	113
TRACTOR CAB-ROOF	114
TRACTOR CAB-ROOF	115
TRACTOR CAB-AIR CONDITIONING	116
TRACTOR CAB-AIR CONDITIONER - EVAPORATOR	117
TRACTOR CAB-BLOWER UNIT	118
TRACTOR CAB-FLOOR PANELS	119
TRACTOR CAB-TRIM	120
TRACTOR CAB-ELECTRICAL WIRING	121
TRACTOR CAB-WINDSCREEN WIPER AND MIRRORS	122
TRACTOR CAB-CAB LIGHTING	123
TRACTOR CAB-RADIO INSTALLATION	124
SEAT-BOSTROM	125
LIGHTING EQUIPMENT-REAR - TRACTORS WITH CAB - UP TO B18008	126
HEXAGON HEAD BOLTS - DIMENSIONS:- 'X' = DIAMETER, 'Y' = OVERALL LENGTH, 'Z' = THREAD LENGTH,(E.G. M8 X 35/22)	127
CARRIAGE BOLTS - DIMENSIONS:- 'X' = DIAMETER, 'Y' = OVERALL LENGTH, 'Z' = THREAD LENGTH,(E.G. M8 X 35/22)	128
HEXAGON SETSCREWS - DIMENSIONS:- 'X' = DIAMETER, 'Y' = OVERALL LENGTH, 'Z' = THREAD LENGTH,(E.G. M8 X 35/22)	129
MISCELLANEOUS SCREWS - DIMENSIONS:- 'X' = DIAMETER, 'Y' = OVERALL LENGTH, 'Z' = THREAD LENGTH,(E.G. M8 X 35/22)	130
HEXAGON NUTS-MISCELLANEOUS	131
WASHERS	132

3-0001-085-B

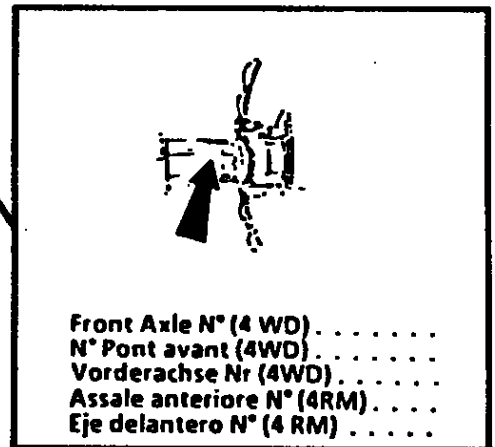
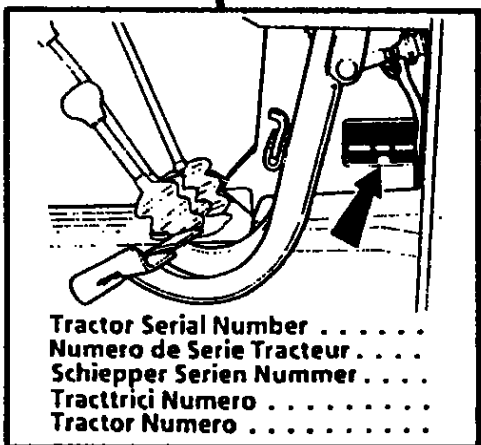
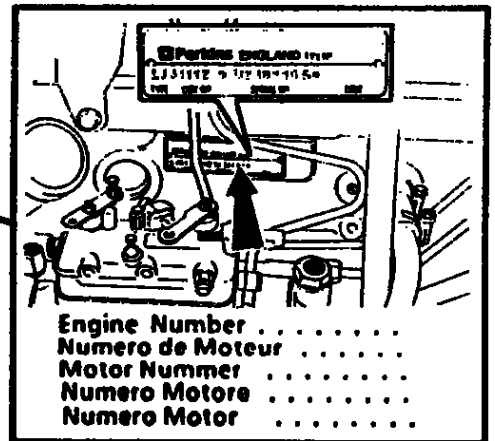
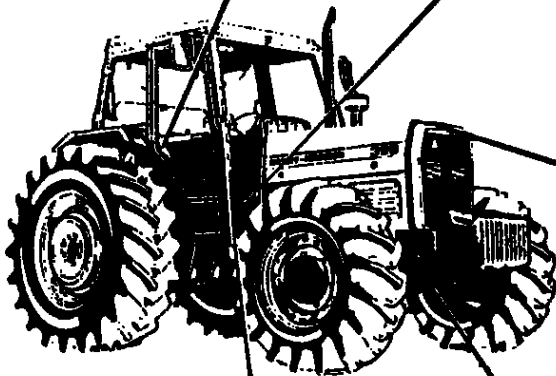
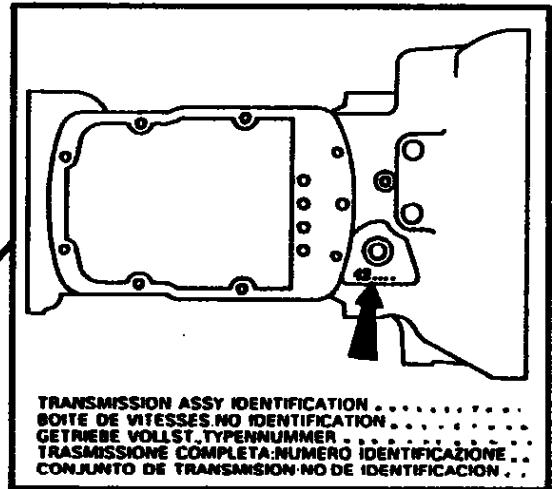
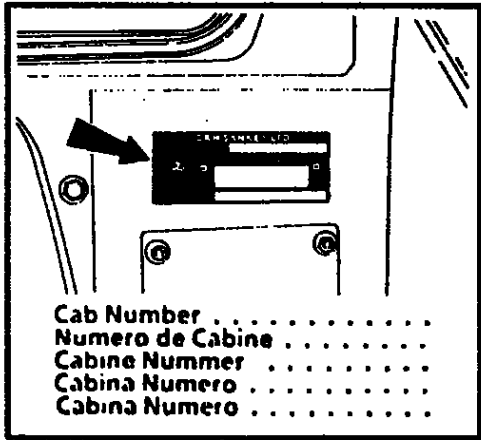

SECTION DIVIDER

Description	Comments
.	For UK only or any text in English only SERIAL NUMBERS
.	For France only or any text in French only NUMEROS DE SERIES
.	For Germany only or any text in German only SERIEN NUMMER
.	For Italy only or any text in Italian only MATR.O NUMERO
.	E NUMERO SERIE

3-AA02-028-B

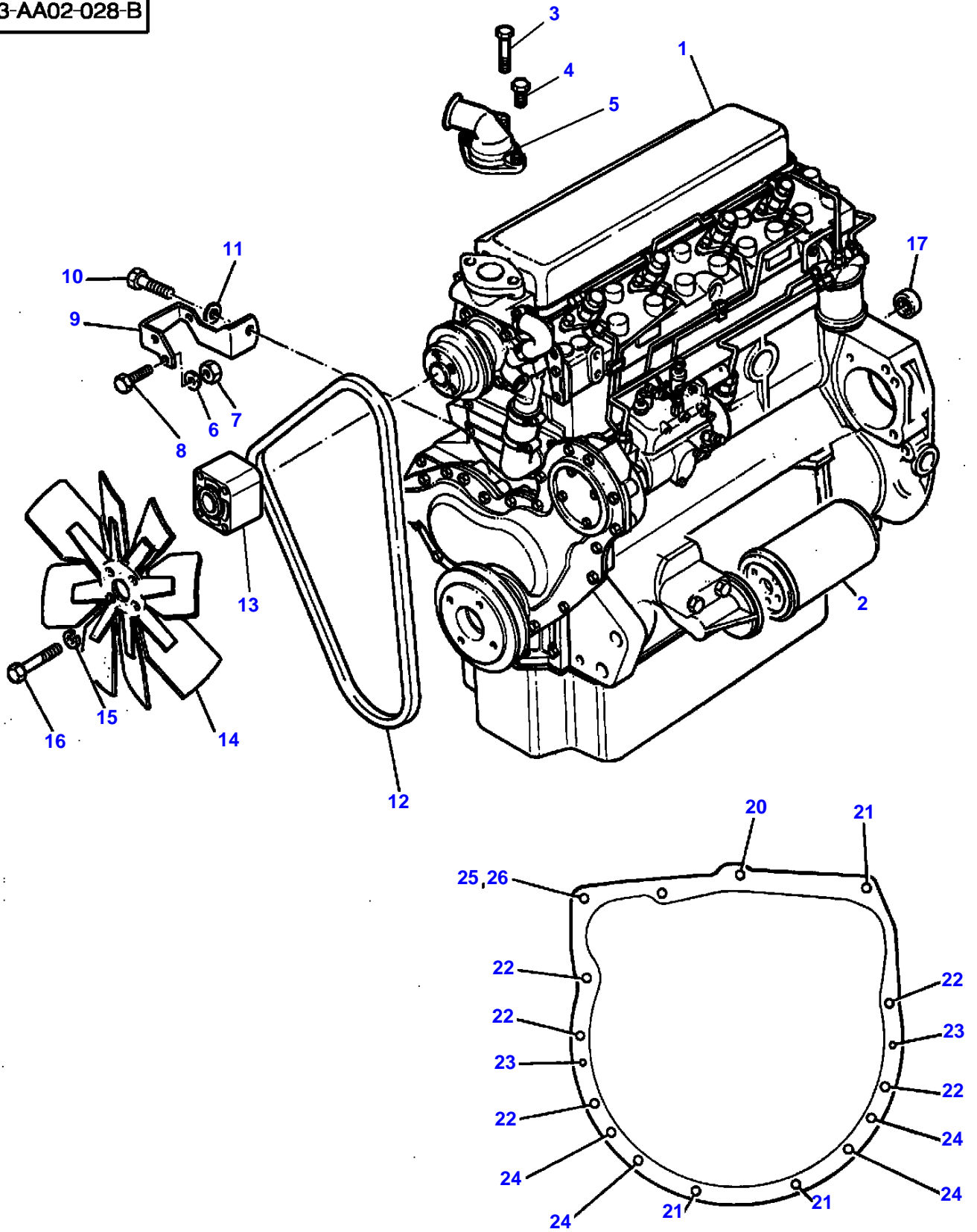

ENGINE INSTALLATION

Item	Part Number	Qty	Description	Comments
1	3761005M91	1	Engine	PEL - LF31258 Repairs and replaces 3701278M91
1	3476392M91	1	Short Engine	PEL - LF39307
2	1447048M1	1	Oil Filter	
3	354502X1	1	Bolt Unf	3/8 UNF X 3.12
4	353546X1	1	Screw	3/8 UNF X 2"
5	3701434M1	1	Connection	
6	353755X1	1	Washer	
7	355565X1	1	Nut Unc	
8	376334X1	1	Screw Unc	
9	1694276M4	1	Bracket	
10	353536X1	1	Screw Unf	
11	353756X1	1	Washer	
12	3700658M91	1	Kit, V Belt	
13	3638568M1	1	Spacer	Thickness 55,8MM
14	3700577M1	1	Fan	8 BLADE
15	353770X1	4	Washer	
16	378805X1	4	Bolt Unf	
17	828123M2	1	Bearing Assy	
21	3019851X1	3	Bolt Metric	
22	3019853X1	5	Bolt Metric	
23	825302M1	2	Dowel	
24	3019855X1	4	Bolt Metric	
25	3019878X1	1	Bolt Metric	
26	3019862X1	1	Nut Metric	
27	3019858X1	1	Bolt Metric	..

L-0560-53M-A

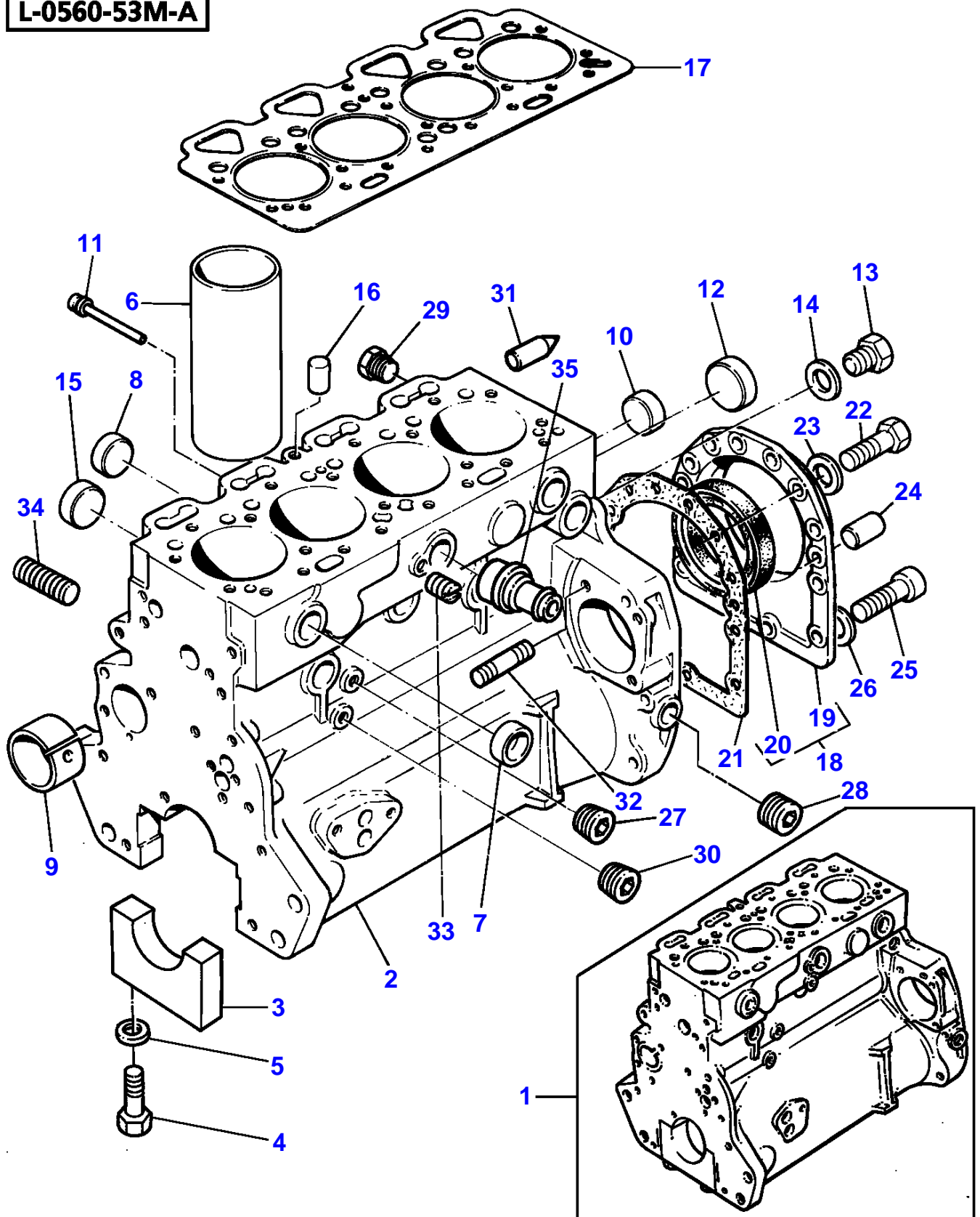

CYLINDER BLOCK - A4.248 ENGINE

Item	Part Number	Qty	Description	Comments
				A4.248 ENGINE
1	ZZ 50162	1	Kit,Cyl.Block	
2		1	Cylinder Block	(1) Not serviced, order REF.1
3		5	Bearing Cap	(1) Not serviced, order REF.1
4	32166329	10	Bolt	(1)
5	33142111	10	Thimble	(1)
6	3135X033	4	Liner	(1) (A)
6	3135X034	X	Liner	(B)
7	0650710	6	Plug	(1)
8	32418122	4	Plug	(1)
9	31134164	1	Bush	(1)
10	0650710	2	Plug	(1)
11	2485A204	1	Plug	(1)
12	32416105	1	Plug	(1)
13	0650582	1	Plug	(1)
14	3311R003	1	Washer	(1)
15	0650577	4	Plug	(1)
16	32417134	1	Plug	(1)
17	3681E018	1	Head Gasket	
18	4142V064	1	Housing	
19		1	Housing	(18) Not serviced, order REF.18
20	2418F475	1	Seal	(18)
21	36817157	1	Joint	
22	0746211	10	Bolt	
23	0920003	10	Washer	
24	0350009	2	Dowel	
25	2172530	2	Capscrew	
26	33112111	2	Washer	
27	0650588	2	Plug	
28	0650588	1	Plug	
29	32161114	3	Plug	
30	0650594	1	Plug	
31	32452113	1	Pointer	
32	0826481	3	Stud	
33	32114143	1	Plug	
34	0826249	1	Stud	
35	3346C004	1	Adaptor	

(A)
PRESS FIT

(B)
SLIP FIT

L-0563-50M-A

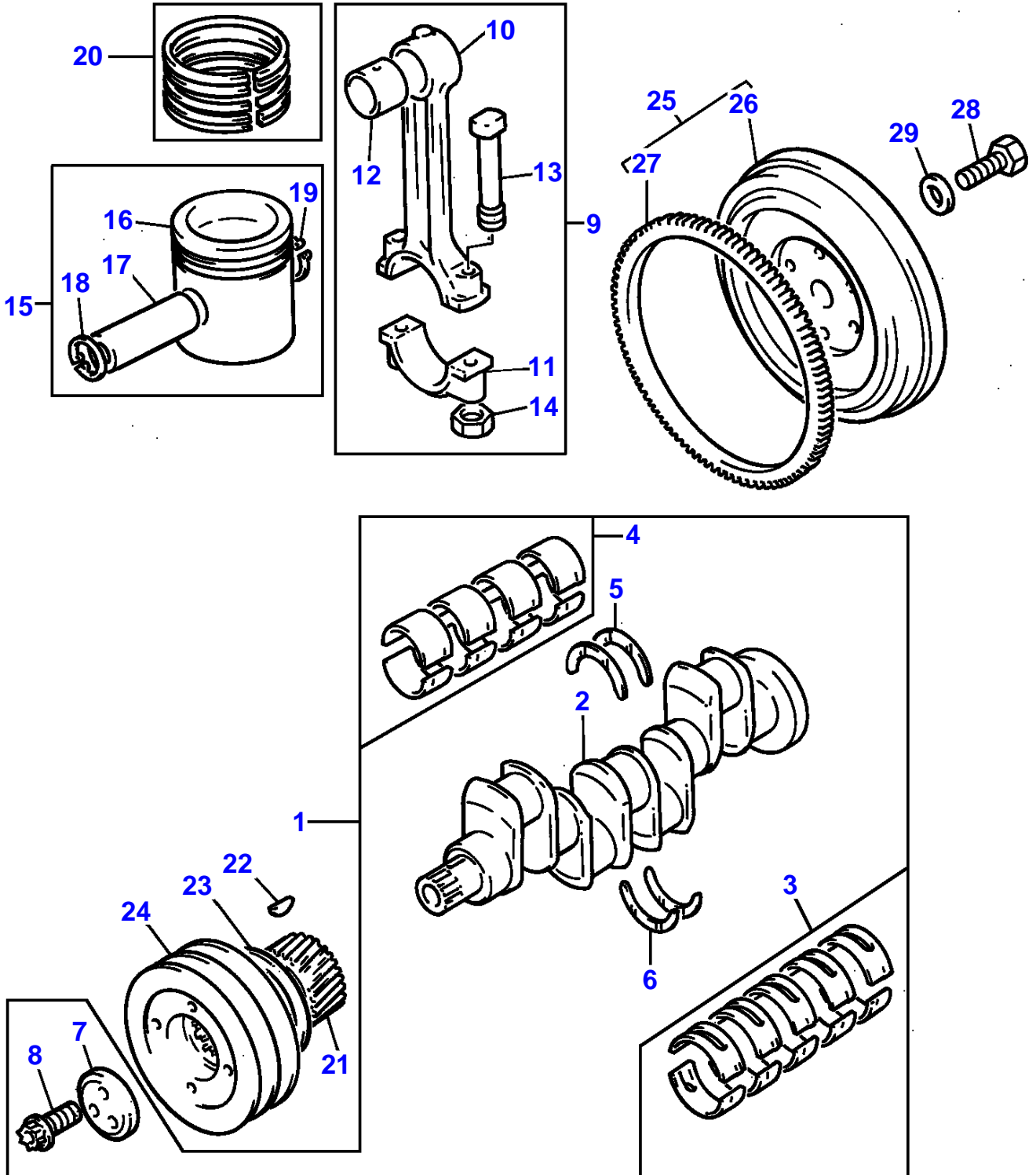

Item	Part Number	Qty	Description	Comments
				A4.248 ENGINE
1	ZZ 90082	1	Kit, Crankshaft	
2		1	Crankshaft	(1) Not serviced, order REF.1
3	81558	1	Kit, Bearing	(1) (A)
3	81558A	X	Kit, Bearing	(A) Thickness (-)0.25MM Thickness (-)0.010"
3	81558B	X	Kit, Bearing	(A) Thickness (-)0.50MM Thickness (-)0.020"
3	81558C	X	Kit, Bearing	(A) Thickness (-)0.75MM Thickness (-)0.030"
4	85042	1	Kit, Bearing	(1) (A)
4	85042A	X	Kit, Bearing	(A) Thickness (-)0.25MM Thickness (-)0.010"
4	85042B	X	Kit, Bearing	(A) Thickness (-)0.50MM Thickness (-)0.020"
4	85042C	X	Kit, Bearing	(A) Thickness (-)0.75MM Thickness (-)0.030"
5	31137551	2	Thrust Washer	(1)
	31137312	X	Thrust Washer	Thickness (+)0.19MM Thickness (+)0.0075"
6	31137561	2	Thrust Washer	(1)
	31137322	X	Thrust Washer	Thickness (+)0.19MM Thickness (+)0.0075"
7	3242T001	1	Thrust Block	(1)
8	32186139	3	Screw	(1)
9	ZZ 90009	4	Kit, Conrod	
10		1	Conrod	(9) Not serviced, order REF.9
11		1	Cap	(9) Not serviced, order REF.9
12	31134123	1	Bush	(9)
13	32762144	2	Bolt	(9)
14	33221328	2	Nut	(9)
15	U5LU0005	4	Kit, Piston	(B)
	U5LP0009	4	Kit, Piston	(C)
16		1	Piston	(15) Not serviced, order REF.15
17		1	Pin	(15) Not serviced, order REF.15
18	2721A029	1	Circlip	(15)
19	2721A029	1	Circlip	(15)
20	41158022	4	Kit, Piston Ring	
21	31171681	1	Gear,Crankshaft	Number of teeth/spines 28
22	0500012	1	Woodruff Key	
23	33125416	1	Washer	
24	3115P021	1	Pulley,Crank	
25	41117084	1	Flywheel	
26		1	Flywheel	(25) Not serviced, order REF.25
27	0410236	1	Starter Ring	(25) Number of teeth/spines 115
28	32162203	6	Screw	
29	33117127	6	Washer	
				(A) PRE-FINISHED
				(B) UNTOPPED

MASSEY FERGUSON

MF 382 N TRACTOR, JAPAN ONLY - 819792

819792

CRANKSHAFT, PISTONS AND CONNECTING RODS - A4.248 ENGINE

4

Item	Part Number	Qty	Description	Comments
				(C) PRE-TOPPED

L-0566-53M-A

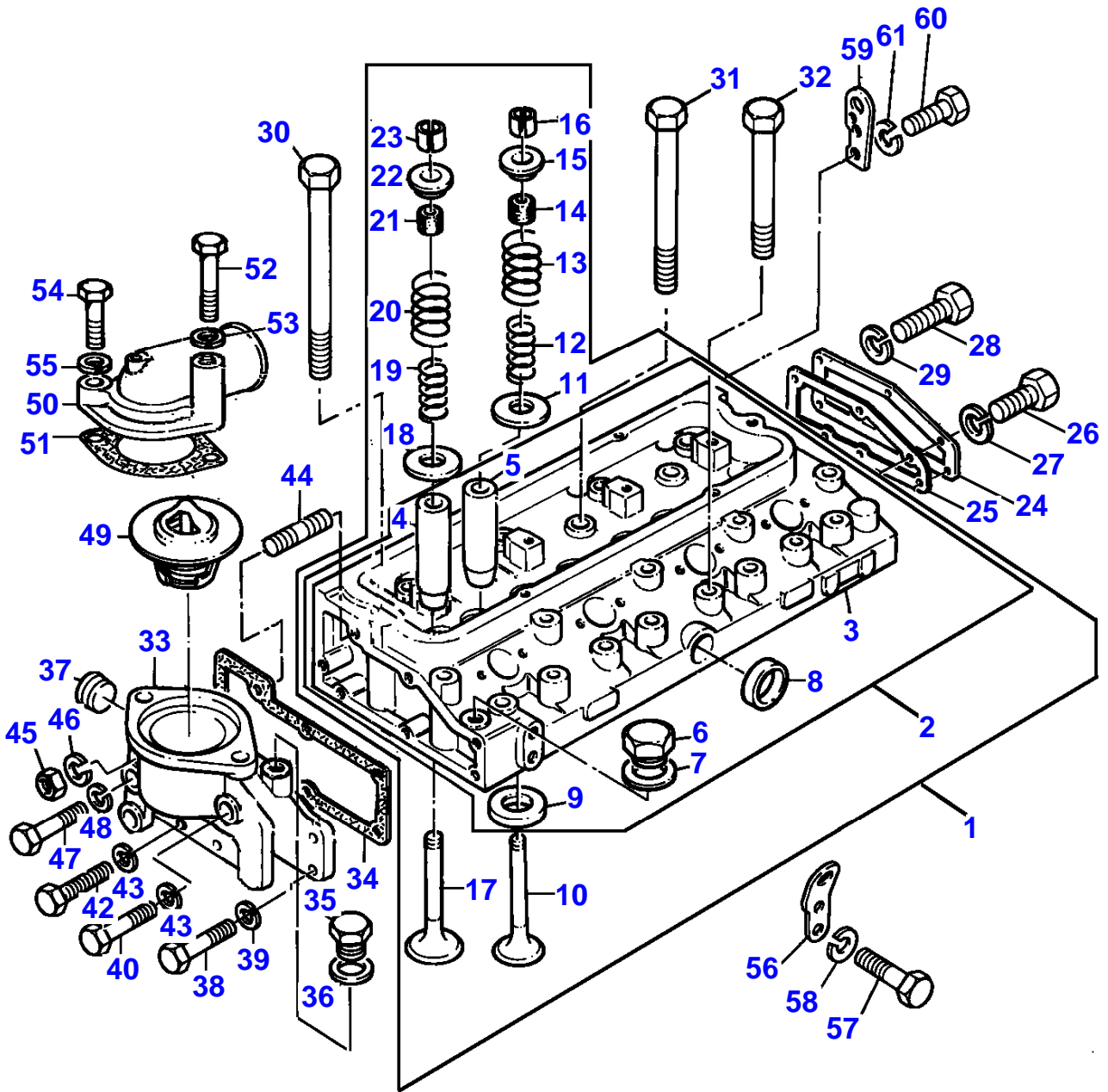

Buy Now



Our support email:

ebooklibonline@outlook.com