

**PUMA 165
PUMA 180
PUMA 195
PUMA 210
Tractors**

Operator's Manual

Print No. 84140686

3rd edition

English 07/08

Replaces p/n 87732574

CASE II
AGRICULTURE

PUMA 165
PUMA 180
PUMA 195
PUMA 210
Tractors

Operator's Manual

Print No. 84140686

3rd edition

English 07/08

Replaces p/n 87732574



CONTENTS

Title	Page
Section 1 - General Information and Safety	
To the Owner	1-1
Product Identification	1-3
Ecology and the Environment	1-6
Safety Precautions	1-7
Safety Decals	1-15
International Symbols	1-21
Airborne Noise Emission	1-22
Section 2 - Controls, Instruments and Operation	
Cab	2-6
Electrical Power Sockets	2-21
Seats	2-24
Handbrake, Throttle and Foot Controls	2-32
Instrument Console	2-34
Analogue/Digital Instruments	2-38
Full Powershift Transmission	2-80
Differential Lock and Four Wheel Drive	2-100
Section 3 - Field Operation	
Important Information	3-2
Boosting the Tractor Battery	3-7
Starting the Engine	3-8
Stopping the Engine	3-11
Power Management	3-13
Constant Engine Speed	3-14
Headland Management Control	3-16
Turn Assist	3-28
Rear Power Take-Off	3-30
Front Power Take-Off and Hydraulic Lift	3-45
Electronic Hitch Control	3-66
Remote Control Valves	3-78
Electro-Hydraulic Remote Control Valves	3-86
Three-point Hitch	3-109
Quick Hitch	3-115
Linkage Stabilisers	3-117
Drawbars and Towing Attachments	3-123
Trailer Braking Systems	3-139
Front Wheel Track Adjustment	3-146
Steerable Front Fenders	3-154
Rear Wheel Track Adjustment	3-156
Ballasting and Tyres	3-167

Section 4 - Lubrication and Maintenance

General Information	4-1
Guard Removal	4-7
Lubrication and Maintenance Chart	4-11
Servicing: When Warning Lights Illuminate	4-14
10-hour/daily service	4-18
50-hour service	4-19
100-hour service	4-31
300-hour service	4-30
600-hour service	4-33
1200-hour/12 month service	4-41
1200-hour/24 month service	4-48
Every 3 years	4-55
General Maintenance - as required	4-57
Storing the Tractor	4-76

Section 5 - Fault Finding

Introduction	5-1
Engine	5-4
Transmission	5-7
Hydraulics	5-8
3-point Hitch	5-9
Brakes	5-10
Cab	5-10
Electrical	5-11

Section 6 - Accessories

AFS 200 Monitor	6-2
Rotating Beacon	6-3
Auxiliary Headlights	6-3
Battery Isolator Switch	6-4

Section 7 - Specification

General Dimensions	7-2
Vehicle Weights	7-6
Lubricant and Fluid Capacities	7-7
Engine	7-8
Fuel System	7-8
Cooling System	7-9
Transmission Options	7-9
Maximum Operating Angle	7-10
Rear Power Take-Off	7-10
Front Power Take-Off	7-10
Hydraulic System	7-11
Rear 3-Point Hitch	7-11
Remote control valves	7-15
Front 3-Point Hitch	7-15
Front Remote Valves	7-15
Brakes	7-16
Steering	7-16
Electrical Equipment	7-17
Hardware Torque Tables	7-18

Section 8 - First 50-hour Service Forms	8-1
--	------------

Section 9 - Index	9-1
--------------------------------	------------

Section 10 - Supplemental Information	10-1
3-Pin Implement Socket	10-2
Proportional Joystick	10-3
Hydraulic Power Boost	10-5
110mm Assist Rams	10-6
Gross Vehicle Weight	10-8
Transmission/Hydraulic Oil Filter Change	10-9

SECTION 1

GENERAL INFORMATION AND SAFETY

TO THE OWNER

GENERAL

This Manual has been prepared to assist you in the correct procedure for running-in, driving and operating and for the maintenance of your new tractor. Read this Manual carefully. Your tractor is intended for use in normal and customary agricultural applications.

If at any time you require advice concerning your tractor, do not hesitate to contact your authorised dealer. He has factory trained personnel, genuine manufacturers' parts and the necessary equipment to carry out all your service requirements.

Your tractor has been designed and built to give maximum performance, economy and ease of operation under a wide variety of operating conditions. Prior to delivery, the tractor was carefully inspected, both at the factory and by your dealer to ensure that it reaches you in optimum condition. To maintain this condition and ensure trouble-free operation, it is important that the routine services, as specified in Section 4 of this Manual, are carried out at the recommended intervals.

OPERATORS MANUAL STORAGE

A storage pocket for the Operators Manual can be found on the rear of the seat. The manual should be kept in this pocket at all times when not in use.

SAFETY

Pages 1-7 to 1-14 inclusive list the precautions to be observed to ensure your safety and the safety of others. Read the safety precautions and follow the advice offered **before** operating the tractor.

CLEANING THE TRACTOR

Your tractor is a state-of-the-art machine with sophisticated, electronic controls. This should be taken into consideration when cleaning the tractor, particularly if using a high pressure washer. Even though every precaution has been taken to safeguard electronic components and connections, the pressure generated by some of these machines is such that complete protection against water ingress cannot be guaranteed.

When using a high pressure washer, do not stand too close to the tractor and avoid directing the jet at electronic components, electrical connections, breathers, seals, filler caps, etc. Never direct a cold water jet at a hot engine or exhaust.

ELECTRO-MAGNETIC INTERFERENCE (EMC)

This tractor complies strictly with the European Regulations on electro-magnetic emissions. However, interference may arise as a result of add-on equipment which may not necessarily meet the required standards. As such interference can result in serious malfunction of the unit and/or create unsafe situations, you must observe the following:

- Ensure that each piece of non-Case IH equipment fitted to the tractor bears the CE mark.
- The maximum power of emission equipment (radio, telephones, etc.) must not exceed the limits imposed by the national authorities of the country where you use the tractor.
- The electro-magnetic field generated by the add-on system should not exceed 24 V/m at any time and at any location in the proximity of electronic components.

Failure to comply with these rules will render the Case IH warranty null and void.

FIRST 50 HOUR SERVICE

In Section 8, at the back of this Manual, you will find the 50-hour service reports.

After you have operated the tractor for 50 hours, take your tractor, together with this Manual, to your dealer. He will then perform the factory recommended 50 hour service and complete the service report sheets (pages 8-1 and 8-3). The first sheet (page 8-1) is the dealer's copy and should be removed by the dealer after the service has been carried out. The second sheet (page 8-3) is your copy of the service performed. **Ensure that you and the dealer sign both copies.**

SERVICE PARTS

It should be pointed out that genuine parts have been examined and approved by the Company. The installation and/or use of 'non-genuine' products could have negative effects upon the design characteristics of your tractor and thereby affect its safety. The Company is not liable for any damage caused by the use of 'non-genuine' parts and accessories. Only genuine Case IH replacement parts should be used. The use of non-genuine parts may invalidate legal approvals associated with this product.

It is prohibited to carry out any modifications to the tractor unless specifically authorised, in writing, by the After Sales Service department of the Company.

WARRANTY

Your tractor is warranted according to legal rights in your country and the contractual agreement with the selling dealer. No warranty shall, however, apply if the tractor has not been used, adjusted and maintained according to the instructions given in the Operator's Manual.

BIODIESEL FUELS

IMPORTANT: Before using Biodiesel fuels in your tractor, refer to the information on page 4-5 regarding the storage and use of Biodiesel fuels.

PRODUCT IDENTIFICATION

The tractor and major components are identified using serial numbers and/or manufacturing codes. Tractor identification data must be supplied to the dealer when requesting parts or service and will also be needed to aid in identifying the tractor if it is ever stolen.

The following provides the locations of the identification data.

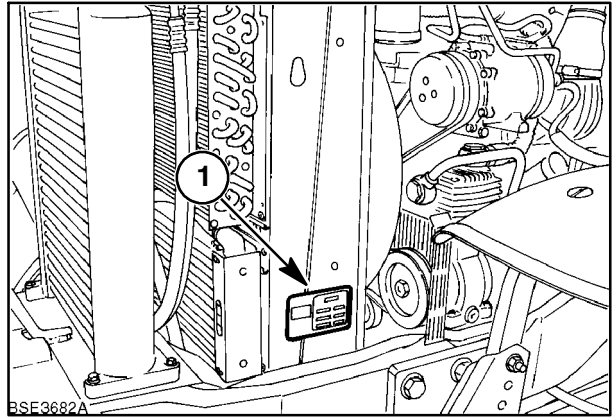

1

Vehicle Identification Plate

The vehicle identification plate, (1) Figure 1 is located on the left-hand radiator support. Record the information on the sample identification plate provided below.

CNH INTERNATIONAL S.A.	TRACTOR NUMBER []
	MODEL []
	DRIVELINE []
	ENGINE []
	HYDRAULIC PUMP []
	HYDRAULIC LIFT []
	FRONT AXLE []
	Made in England

2

Tractor Identification

The serial number and model identification information is stamped on the right-hand side of the front support (1). These numbers are also repeated on the vehicle identification plate reproduced above.

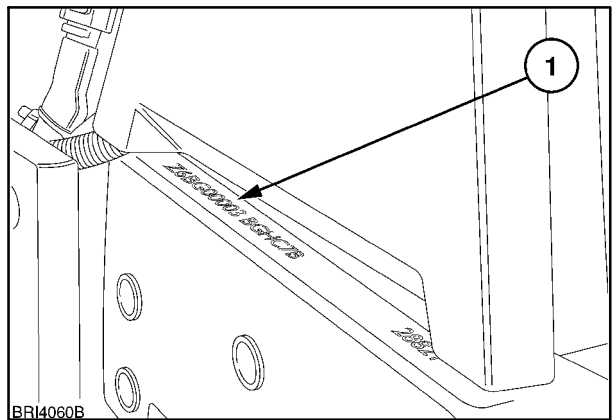

3

Engine Information

The engine serial number and date of manufacture are stamped on the right-hand side of engine block (1), below the manifold. Record the number below.

Engine Serial No. _____

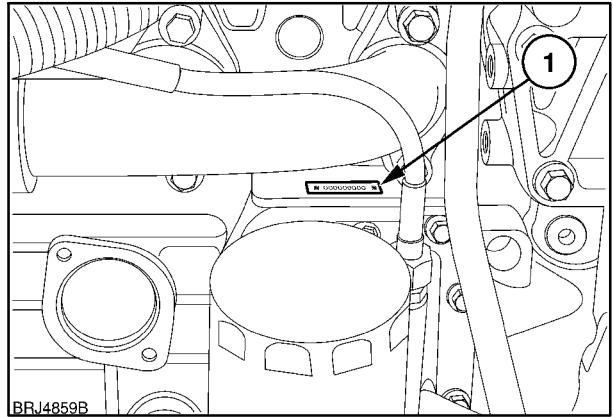

4

The details are repeated on the information plate located on the left side of the engine oil pan.

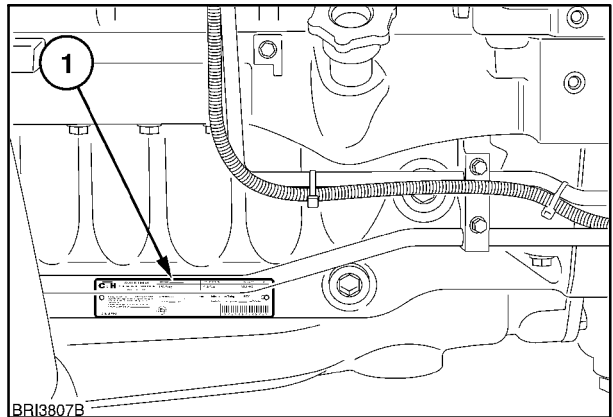

5

Further information relating to engine adjustments and emission level compliance are also shown on the engine information plate.

NOTE: The details displayed on the engine information plate may change according to the country in which the tractor is sold.

	CNH U.K. Limited IMPORTANT ENGINE INFORMATION Assembled in UK	CID/Litre	Engine Serial No.	FEL g/kW-hr	EPA
		E.P.A. Family	Model Type	NOx+MMHC	PM
This engine conforms to US, E.P.A. & California Regulations for large non-road compression ignition diesel engines. This engine is designed to operate on commercially available diesel fuel. When making adjustments set parking brake and block wheels.		Advertised BHP/kW	rpm	Engine Model	Initial Injection Timing
Date of Manufacture		Valve Lash Cold (mm)	Inlet	Exh.	BTDC
e3		Low Idle	rpm	Fuel rate @ advertised power	mm ³ /Stroke
e3		3 8 1 9 3 1 8 7 5 2 0 6 7 8			

Driveline Identification

The serial number plate (1) is located on the right-hand side of the transmission casing behind the battery carrier. This number is repeated on the vehicle identification plate. Record the information below for quick reference.

Driveline Serial No. _____

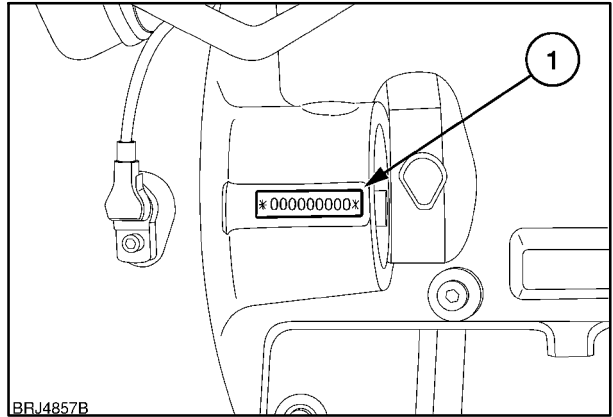

6

Cab Identification

The cab serial number and other information is on the OECD certification plate. This plate can be found on the right-hand side of the cab trim panel, below the rear window. Record the cab serial number below for quick reference.

Cab Serial No. _____

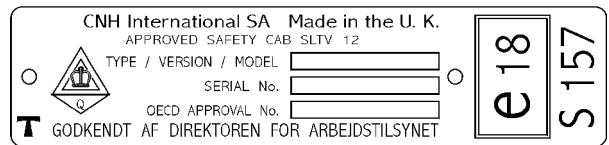

7

Product Identification Number Plate

The Product Identification Number plate provides important information on tractor and towed equipment weight combinations. This plate can be found on the right-hand side of the cab exterior trim panel, below the rear window.

The figures shown are the maximum permissible vehicle and towing weights and should not be exceeded, to do so may affect the safe operation of the tractor. See Drawbars and Towing Attachments in Section 3.

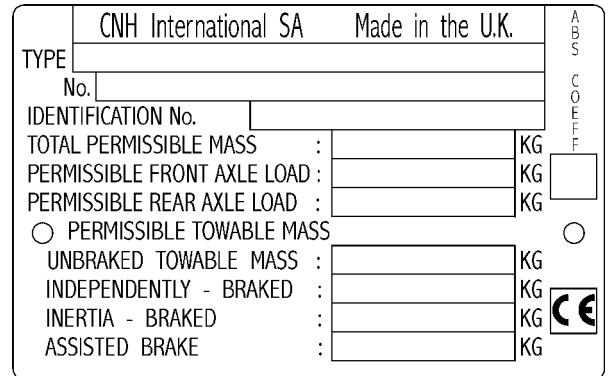

8

ECOLOGY AND THE ENVIRONMENT

Soil, air and water are vital factors of agriculture and life in general. Where legislation does not yet rule the treatment of some of the substances which are required by advanced technology, common sense should govern the use and disposal of products of a chemical and petrochemical nature.

The following are recommendations which may be of assistance:

- Become acquainted with and ensure that you understand the relative legislation applicable to your country.
- Where no legislation exists, obtain information from suppliers of oils, filters, batteries, fuels, anti freeze, cleaning agents, etc., with regard to their effect on man and nature and how to safely store, use and dispose of these substances. Agricultural consultants will, in many cases, be able to help you as well.

HELPFUL HINTS

1. Avoid filling tanks using unsuitable containers or inappropriate pressurised fuel delivery systems which may cause considerable spillage.
2. In general, avoid skin contact with all fuels, oils, acids, solvents, etc. Most of them contain substances which can be harmful to your health.
3. Modern oils contain additives. Do not burn contaminated fuels and/or waste oils in ordinary heating systems.
4. Avoid spillage when draining off used engine coolant mixtures, engine, gearbox and hydraulic oils, brake fluids, etc. Do not mix drained brake fluids or fuels with lubricants. Store them safely until they can be disposed of in a proper way to comply with local legislation and available resources.
5. Modern coolant mixtures, i.e. antifreeze and other additives, should be replaced every two years. They should not be allowed to get into the soil but should be collected and disposed of safely.
6. Do not open the air-conditioning system yourself. It contains gases which should not be released into the atmosphere. Your dealer or air conditioning specialist has a special extractor for this purpose and will have to recharge the system anyway.
7. Repair any leaks or defects in the engine cooling or hydraulic system immediately.
8. Do not increase the pressure in a pressurised circuit as this may lead to the components exploding.
9. Protect hoses during welding as penetrating weld splatter may burn a hole or weaken them, causing the loss of oils, coolant, etc.

SAFETY PRECAUTIONS

A careful operator is the best operator. Most accidents can be avoided by observing certain precautions. To help prevent accidents, read and take the following precautions **before** driving, operating or servicing the tractor. Equipment should be operated only by those who are responsible and instructed to do so.

PRECAUTIONARY STATEMENTS

Throughout this Manual you will see text, preceded by the words **NOTE**, **ATTENTION**, **IMPORTANT**, **CAUTION**, **WARNING** or **DANGER**. Such text has the following significance:

MACHINE SAFETY

NOTE: This text stresses a correct operating technique or procedure.

ATTENTION: This text warns the operator of potential machine damage if a certain procedure is not followed.

IMPORTANT: This text informs the reader of something that he needs to know to prevent minor machine damage if a certain procedure is not followed.

PERSONAL SAFETY



The word **CAUTION** is used where a safe behavioural practice, according to operating and maintenance instructions and common safety practices will protect the operator and others from accident involvement.



The word **WARNING** denotes a potential or hidden hazard which could possibly cause serious injury. It is used to warn operators and others to exercise due care and attention to avoid a surprise accident with machinery.



The word **DANGER** denotes a forbidden practice in connection with a serious hazard.

Failure to follow the **CAUTION**, **WARNING** and **DANGER** instructions may result in serious bodily injury or even death.

THE TRACTOR

1. Read the Operator's Manual carefully before using the tractor. Lack of operating knowledge can lead to accidents.
2. Only allow properly trained and qualified persons to operate the tractor.
3. To prevent falls, use the handrails and step plates when getting on and off the tractor. Keep steps and platform clear of mud and debris.
4. Replace all missing, illegible or damaged safety decals.
5. Keep safety decals free of dirt or grime.



6. Do not permit anyone but the operator to ride on the tractor except for driver training or instruction. When used for these purposes an additional seat may be fitted in the cab. Passengers should not be carried on the tractor at any time.
7. Keep children away from the tractor and farm machinery at all times.
8. Do not modify or alter or permit anyone else to modify or alter the tractor or any of its components or any tractor function without first consulting your dealer.
9. Install all guards before starting the engine or operating the tractor.

Buy Now



Our support email:

ebooklibonline@outlook.com