

NEW HOLLAND

T7030

T7040

T7050

T7060

T7070

With SideWinder™ II Armrest

84257389

replaces p/n 87636357

OPERATOR'S MANUAL

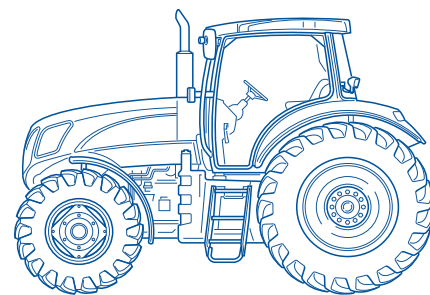

ORIGINAL INSTRUCTIONS - according to Directives 2006/42/EC, Annex I 1.7.4.1

OPERATOR'S MANUAL

T7030

T7040

T7050

T7060

T7070

With SideWinder™ II Armrest

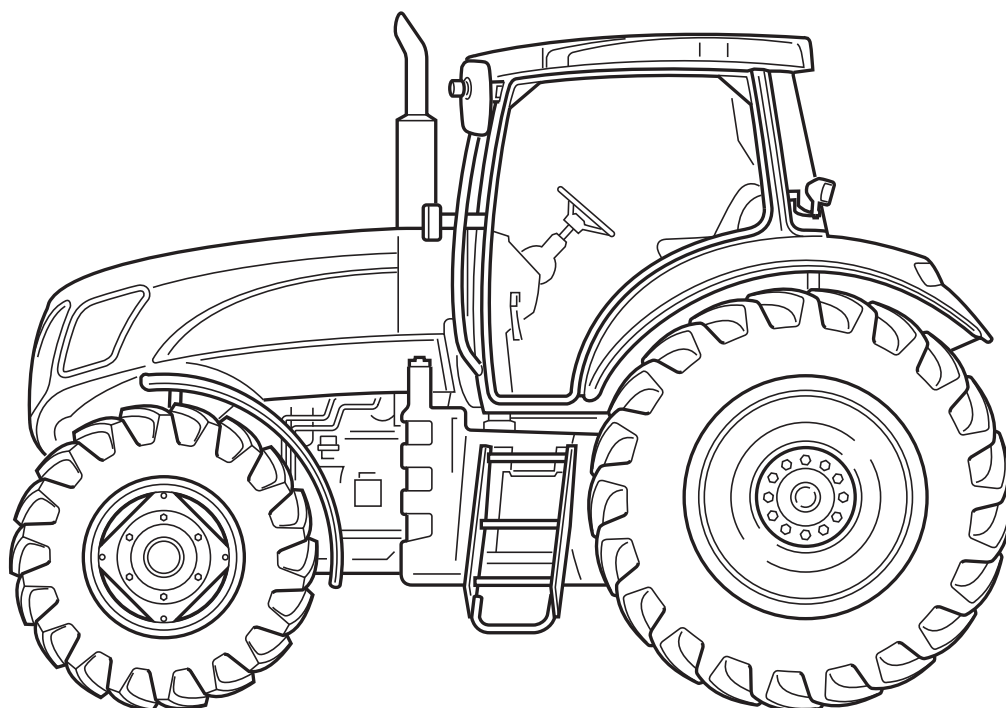

Print No. 84257389

2nd edition

NA English 08/09

Replaces p/n 87636357



TO THE OWNER

This manual contains information concerning the adjustment and maintenance of your New Holland T7030, T7040, T7050, T7060 Tractor. You have purchased a dependable machine, but only by proper care and operation can you expect to receive the performance and long service built into this tractor. Please have all operators read this manual carefully and keep it available for ready reference.

This machine was designed to power and propel itself. It is intended to load and move materials with a variety of buckets and forks. Allied attachments built and supplied by other manufacturers can be used on the tractor where recommended and approved by New Holland.

DO NOT use this machine for any purpose or in any manner other than as described in this manual, decals, or other product safety information provided with this machine. These materials define the machine's intended use.

All persons who will be operating this machine shall possess a valid local vehicle operating permit and/or other applicable local age work permits.

Your New Holland dealer will instruct you in the general operation of your tractor. (Refer to the "Delivery Report" at the back of this manual.) Your dealer's staff of factory-trained service technicians will be glad to answer any questions that may arise regarding the operation of your tractor.

Your New Holland dealer carries a complete line of genuine New Holland service parts. These parts are manufactured and carefully inspected to insure high quality and accurate fitting of any necessary replacement parts. Be prepared to give your dealer the model and PIN number of the engine and tractor, when ordering parts. Locate these numbers now and record them below. Refer to the "General Information" section of this manual for the location of the model and PIN numbers of your tractor.

Model _____ Engine Model _____

PIN Number _____ Engine Serial Number _____

IMPROVEMENTS

CNH America LLC is continually striving to improve its products. We reserve the right to make improvements or changes when it becomes practical and possible to do so, without incurring any obligation to make changes or additions to the equipment sold previously.

CONTENTS

SECTION 0

To the Owner	0-1
Improvements	0-1

SECTION 1

General Information and Safety	1-1
End User License Agreement Terms	1-2
Product Identification	1-3
Ecology and the Environment	1-7
Precautionary Statements	1-8
Personal Safety	1-8
Machine Safety	1-8
Information	1-8
Safety Precautions	1-9
Operator Protective Structure	1-16
Fire or Explosion Prevention	1-17
Fire Prevention - Engine Area	1-18
Service Area, Fire Extinguisher, First Aid Kit	1-19
Safety Decals	1-20
International Symbols	1-26
Airborne Noise Emission	1-27

SECTION 2

Controls, Instruments, and Operation	2-1
Integrated Control Panel	2-2
Cab	2-5
Seats	2-23
Instrument Console	2-30
Analog/Digital Instrument Cluster	2-33
Instrument Panel Displays	2-37
Enhanced Keypad and Performance Monitor (Where Fitted)	2-52
Programming the Displays	2-56
Power Command Transmission	2-80
Auto Command Transmission	2-104
Differential Lock	2-125
Four Wheel Drive (Where Fitted)	2-127
Terraglide™ Front Axle Suspension (Where Fitted)	2-130

SECTION 3

Field Operations	3-1
Starting the Engine	3-4
Engine Power Management	3-9
Engine Speed Management	3-10
Custom Headland Management	3-16
Fast Steer (Where Fitted)	3-36
Rear Power Take-off	3-38
Front P.T.O. and 3-Point Hitch (Where Fitted)	3-56
Electronic Draft Control	3-72
Electro-Hydraulic Remote Valves (Where Fitted)	3-87
Continuous Oil Supply for Remote Service (Where Fitted)	3-115
Three-point Hitch	3-120
Drawbars and Towing Attachments	3-128
Hydraulic Trailer Brakes	3-132
Front Wheel Track Adjustment (Four Wheel Drive)	3-133
Wheels with Cast Center Disc	3-143
Ballasting and Tires	3-146

SECTION 4

Lubrication and Maintenance	4-1
General Lubrication and Maintenance Information	4-1
Protective Guards	4-6
Lubricants and Coolants	4-8
Lubricant and Coolant Specification	4-10
Lubrication and Maintenance Chart	4-11
When the Warning Symbol Appears	4-13
Every 10 Hours of Operation or Daily (Whichever Occurs First)	4-16
Every 50 Hours Complete the Preceding Operations Plus the Following	4-18
Every 300 Hours Carry Out the Preceding Checks Plus the Following	4-28
Every 600 Hours Carry Out the Preceding Checks Plus the Following	4-32
Every 1200 Hours or 12 Months (Whichever Occurs First) Carry Out the Preceding Checks Plus the Following	4-40
Every 1200 Hours or 2 Years (Whichever Occurs First) Carry Out the Preceding Checks Plus the Following	4-49
Every 3 Years Carry Out the Following	4-55
General Maintenance (To Be Performed as and When Required)	4-56
Protecting the Electronic and Electrical Systems During Battery Charging or Welding	4-81
Storing the Tractor	4-82

SECTION 5

Troubleshooting 5-1

SECTION 6

Accessories 6-1

SECTION 7

Specifications 7-1

General Dimensions All Models 7-2

Minimum Hardware Tightening Torques 7-18

SECTION 8

Delivery Report 8-1

First 50 Hour Service 8-5

Check and Adjust, as Required 8-5

(North America Only)
(California Only)

CALIFORNIA

Proposition 65 Warning

Diesel engine exhaust and some of its constituents are known to the State of California to cause cancer, birth defects, and other reproductive harm.

Battery posts, terminals and related accessories contain lead and lead compounds. Wash hands after handling.

SECTION 1

GENERAL INFORMATION AND SAFETY

GENERAL

This Manual has been prepared to assist you in the correct procedure for running-in, driving and operating and for the maintenance of your new tractor. Read this Manual carefully. Your tractor is intended for use in normal and customary agricultural applications.

If at any time you require advice concerning your tractor, do not hesitate to contact your authorized dealer. They have factory trained personnel, genuine manufacturers' parts and the necessary equipment to carry out all your service requirements.

Your tractor has been designed and built to give maximum performance, economy and ease of operation under a wide variety of operating conditions. Prior to delivery, the tractor was carefully inspected, both at the factory and by your dealer to ensure that it reaches you in optimum condition. To maintain this condition and ensure trouble-free operation, it is important that the routine services, as specified in Section 4 of this Manual, are carried out at the recommended intervals.

OPERATORS MANUAL STORAGE

A storage pocket for the Operators Manual can be found on the rear of the seat. The manual should be kept in this pocket at all times when not in use.

CLEANING THE TRACTOR

Your tractor is a state-of-the-art machine with sophisticated, electronic controls. This should be taken into consideration when cleaning the tractor, particularly if using a high pressure washer. Even though every precaution has been taken to safeguard electronic components and connections, the pressure generated by some of these machines is such that complete protection against water ingress cannot be guaranteed.

When using a high pressure washer, do not stand too close to the tractor and avoid directing the jet at electronic components, electrical connections, breathers, seals, filler caps, etc. Never direct a cold water jet at a hot engine or exhaust.

SAFETY

Pages 1-8 to 1-14 inclusive list the precautions to be observed to ensure your safety and the safety of others. Read the safety precautions and follow the advice offered **before** operating the tractor.

FIRST 50 HOUR SERVICE

In Section 8, at the back of this Manual, you will find the 50-hour service reports.

After you have operated the tractor for 50 hours, take your tractor, together with this Manual, to your dealer. He will then perform the factory recommended 50 hour service and complete the service report sheets (pages 8-5 and 8-7). The first sheet (page 8-5) is the dealer's copy and should be removed by the dealer after the service has been carried out. The second sheet (page 8-7) is your copy of the service performed. **Ensure that you and the dealer sign both copies.**

SERVICE PARTS

It should be pointed out that genuine parts have been examined and approved by the Company. The installation and/or use of 'non-genuine' products could have negative effects upon the design characteristics of your tractor and thereby affect its safety. The Company is not liable for any damage caused by the use of 'non-genuine' parts and accessories. Only genuine New Holland replacement parts should be used. The use of non-genuine parts may invalidate legal approvals associated with this product.

It is prohibited to carry out any modifications to the tractor unless specifically authorized, in writing, by the After Sales Service department of the Company.

WARRANTY

Your tractor is warranted according to legal rights in your country and the contractual agreement with the selling dealer. No warranty shall, however, apply if the tractor has not been used, adjusted and maintained according to the instructions given in the Operator's Manual.

END USER LICENSE AGREEMENT TERMS

- You have acquired a device (“DEVICE”) that includes Software licensed by CNH America LLC from Microsoft Licensing, GP or its affiliates (“MS”). Those installed software products of MS origin, as well as associated media, printed materials, and “online” or electronic documentation (“SOFTWARE”) are protected by international intellectual property laws and treaties. The SOFTWARE is licensed, not sold. All rights reserved.
- IF YOU DO NOT AGREE TO THIS END USER LICENSE AGREEMENT (“EULA”), DO NOT USE THE DEVICE OR COPY THE SOFTWARE. INSTEAD, PROMPTLY CONTACT CNH AMERICA LLC FOR INSTRUCTIONS ON RETURN OF THE UNUSED DEVICE(S) FOR A REFUND. **ANY USE OF SOFTWARE INCLUDING BUT NOT LIMITED TO USE ON THE DEVICE, WILL CONSTITUTE YOUR AGREEMENT TO THIS EULA (OR RATIFICATION OF ANY PREVIOUS CONSENT.)**
- **GRANT OF SOFTWARE LICENSE.** This EULA grants you the following license:
 - You may use the SOFTWARE only on the DEVICE.
 - **NOT FAULT TOLERANT.** THE SOFTWARE IS NOT FAULT TOLERANT. CNH AMERICA LLC HAS INDEPENDENTLY DETERMINED HOW TO USE THE SOFTWARE IN THE DEVICE, AND MS HAS RELIED UPON CNH AMERICA LLC TO CONDUCT SUFFICIENT TESTING TO DETERMINE THAT THE SOFTWARE IS SUITABLE FOR SUCH USE.
 - **NO WARRANTIES FOR THE SOFTWARE.** THE SOFTWARE is provided “AS IS” and with all faults. THE ENTIRE RISK AS TO SATISFACTORY QUALITY, PERFORMANCE, ACCURACY AND EFFORT (INCLUDING LACK OF NEGLIGENCE) IS WITH YOU. ALSO, THERE IS NO WARRANTY AGAINST INTERFERENCE WITH YOUR ENJOYMENT OF THE SOFTWARE OR AGAINST INFRINGEMENT. **IF YOU HAVE RECEIVED ANY WARRANTIES REGARDING THE DEVICE OR THE SOFTWARE, THOSE WARRANTIES DO NOT ORIGINATE FROM, AND ARE NOT BINDING ON, MS.**
- **No Liability for Certain Damages.** **EXCEPT AS PROHIBITED BY LAW, MS SHALL HAVE NO LIABILITY FOR ANY INDIRECT, SPECIAL, CONSEQUENTIAL OR INCIDENTAL DAMAGES ARISING FROM OR IN CONNECTION WITH THE USE OR PERFORMANCE OF THE SOFTWARE. THIS LIMITATION SHALL APPLY EVEN IF ANY REMEDY FAILS OF ITS ESSENTIAL PURPOSE. IN NO EVENT SHALL MS BE LIABLE FOR ANY AMOUNT IN EXCESS OF U.S. TWO HUNDRED AND FIFTY DOLLARS (U.S. \$250.00)**
- **Limitations on Reverse Engineering, Decompilation, and Disassembly.** You may not reverse engineer, decompile, or disassemble the SOFTWARE, except and only to the extent that such activity is expressly permitted by application law notwithstanding this limitation.
- **SOFTWARE TRANSFER ALLOWED BUT WITH RESTRICTIONS.** You may permanently transfer rights under this EULA only as part of a permanent sale or transfer of the DEVICE, and only if the recipient agrees to this EULA. If the SOFTWARE is an upgrade, any transfer must also include all prior versions of the SOFTWARE.
- **EXPORT RESTRICTIONS.** You acknowledge that SOFTWARE is subject to U.S. export jurisdiction. You agree to comply with all applicable international and national laws that apply to the SOFTWARE, including the U.S. Export Administration Regulations, as well as end-user, end-use and destination restrictions issued by U.S. and other governments. For additional information see <http://www.microsoft.com/exporting/>.

PRODUCT IDENTIFICATION

The tractor and major components are identified using product identification numbers and/or manufacturing codes.

Tractor identification data must be supplied to the dealer when requesting parts or service and will also be needed to aid in identifying the tractor if it is ever stolen.

The following provides the locations of the identification data.

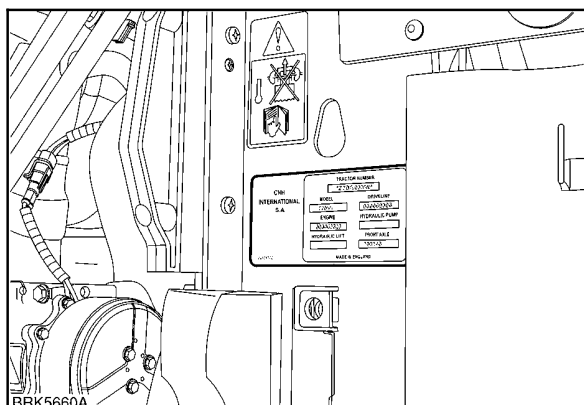

1

Vehicle Identification Plate

The vehicle identification plate, Figure 1, is located on the right-hand radiator support. Record the information on the sample identification plate provided below.

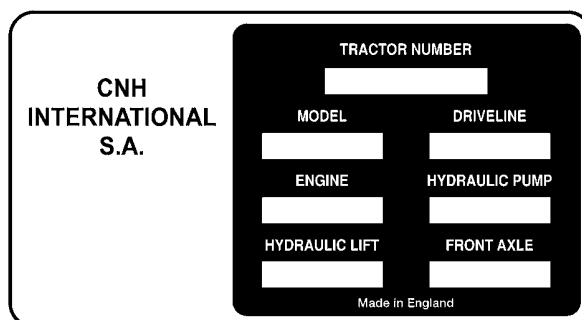

2

Tractor Product Identification Number

The product identification number and model identification information is stamped on the right-hand side of the front support, 1. These numbers are also repeated on the vehicle identification plate reproduced above.

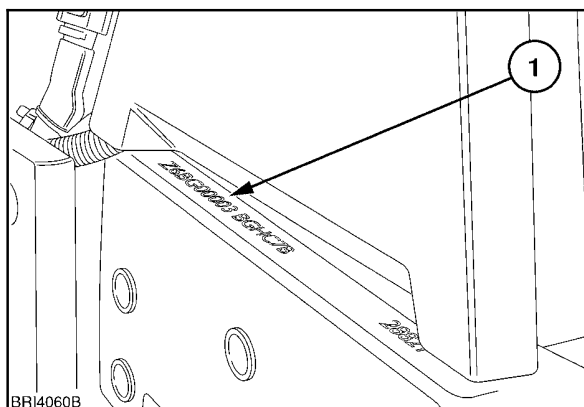

3

SECTION 1 - GENERAL INFORMATION AND SAFETY

Engine Identification

The engine product identification number (PIN) and date of manufacture are stamped on the right-hand side of engine block, 1, below the manifold. Record the number below.

Engine PIN: _____

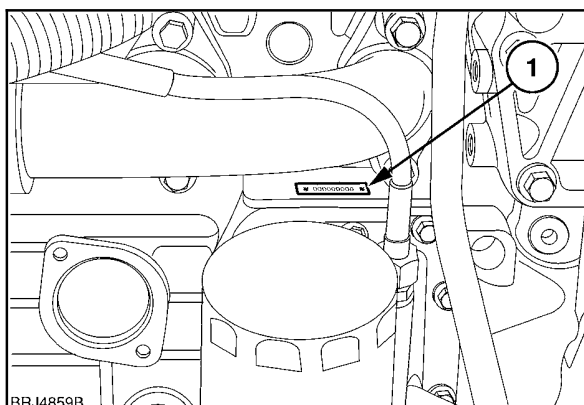

The details are repeated on the information plate located on the left side of the engine oil pan.

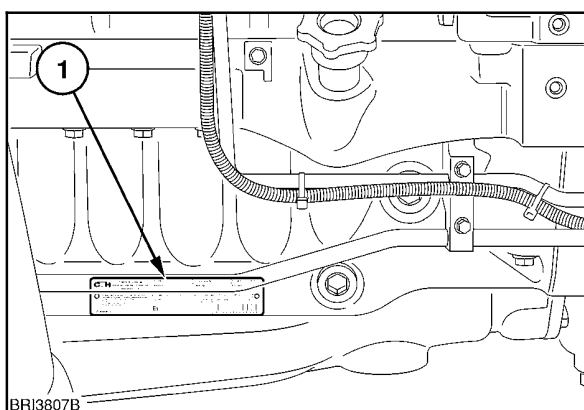

Further information relating to engine adjustments and emission level compliance are also shown on the engine information plate.

NOTICE: The details displayed on the engine information plate may change according to the country in which the tractor is sold.

	CNH U.K. Limited IMPORTANT ENGINE INFORMATION Assembled in UK	CID/Litre	Engine Serial No.	FEL g/kW-hr	EPA	
	This engine conforms to US E.P.A. & California Regulations for large non-road compression ignition diesel engines. This engine is designed to operate on commercially available diesel fuel. When making adjustments set parking brake and block wheels. Date of Manufacture	E.P.A. Family	Model Type	NOx+NMHC	PM	
		Advertised BHP/kW	rpm	Engine Model		
		Valve Lash Cold (mm)	Inlet	Exh.	Initial Injection Timing	BTDC
Low Idle	rpm	Fuel rate @ advertised power		mm ³ /Stroke		
e3 e3			 3 8 1 9 3 1 8 7 5 2 0 6 7 8			

Driveline Identification

Power Command Transmission

The product identification number plate, 1, is located on the right-hand side of the transmission casing behind the battery carrier. This number is repeated on the vehicle identification plate and should be recorded below for quick reference.

Driveline PIN: _____

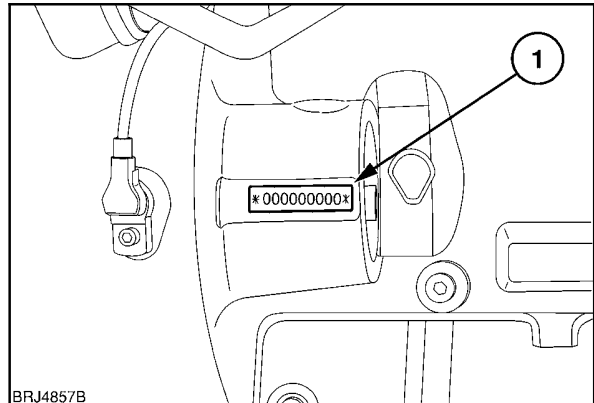

6

Auto Command Transmission

A product identification number plate, 1, is located on top of the transmission casing on the right-hand side of the tractor.

The plate can be found adjacent to the rear of the hydrostatic drive unit. This number is repeated on the vehicle identification plate and should be recorded below for quick reference.

Driveline PIN: _____

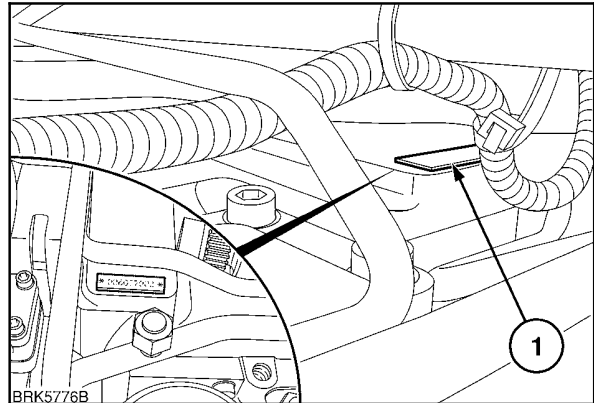

7

Thank you so much for reading.
Please click the “Buy Now!”
button below to download the
complete manual.



After you pay.

You can download the most
perfect and complete manual in
the world immediately.

Our support email:

ebooklibonline@outlook.com