

OPERATOR'S MANUAL

ORIGINAL INSTRUCTIONS - according to Directive 2006/42/EC, Annex I 1.7.4.1

T9030

T9040

T9050

T9060

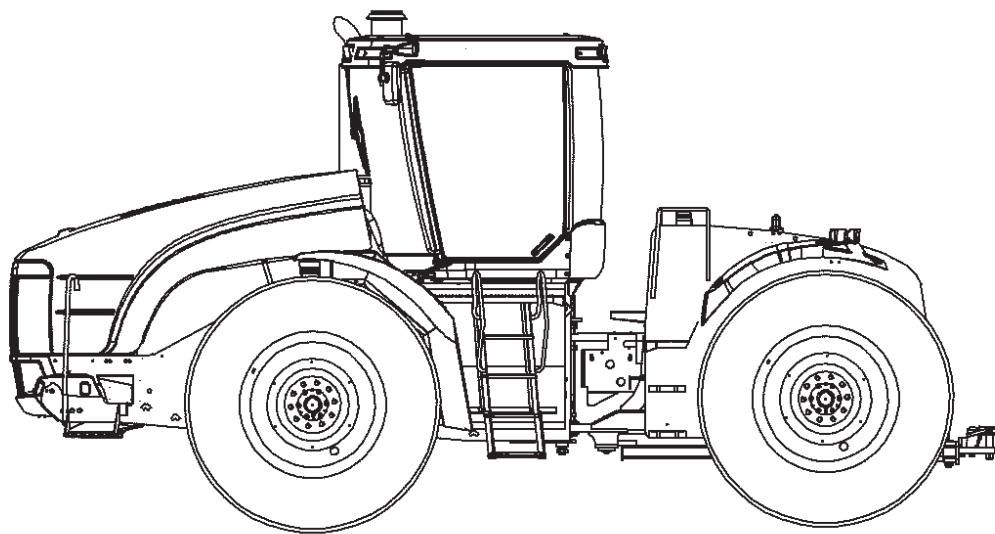

Print No. 84266061

1st edition

English 11/09

From serial no. ZAF218001



PRECAUTIONARY STATEMENTS

PERSONAL SAFETY



This is the safety alert symbol. It is used to alert you to potential personal injury hazards. Obey all safety messages that follow this symbol to avoid possible injury or death.

Throughout this manual and on machine decals, you will find signal words **DANGER**, **WARNING**, and **CAUTION** followed by specific instructions. These precautions are intended for the personal safety of you and those working with you. Please take the time to read them.



DANGER indicates a hazardous situation which, if not avoided, will result in death or serious injury. The color associated with Danger is RED.

M1169A



WARNING indicates a hazardous situation which, if not avoided, could result in death or serious injury. The color associated with Warning is ORANGE.

M1170A



CAUTION, used with the safety alert symbol, indicates a hazardous situation which, if not avoided, could result in minor or moderate injury. The color associated with Caution is YELLOW.

M1171A

FAILURE TO FOLLOW DANGER, WARNING, AND CAUTION INSTRUCTIONS COULD RESULT IN DEATH OR SERIOUS INJURY.

MACHINE SAFETY

NOTICE: *NOTICE is used to address practices not related to personal safety. The color associated with Notice is BLUE.*

The signal word NOTICE is intended for machine safety. It is used throughout this manual followed by specific instructions to prevent machine damage. Failure to follow NOTICE messages could result in machine damage.

INFORMATION

NOTE: *NOTE is used to identify instructions that clarify steps, procedures, or other information in this manual.*

CNH America LLC Technical Manuals

Manuals are available from your Dealer for the operation, service, and repair of your machine. For prompt convenient service, contact your Dealer for assistance in obtaining the manuals for your machine.

Your Dealer can expedite your order for Operator's Manuals, Parts Catalogs, Service Manuals, and maintenance records.

Always give the Machine Name, Model, and P.I.N. (Product Identification Number) or S.N. (Serial Number) of your machine so your Dealer can provide the correct manuals for your machine.

The company is continually striving to improve its products and therefore reserves the right to make improvements and changes when it becomes practical and possible to do so, without incurring any obligation to make changes or additions to the equipment sold previously.

All data given in this manual is subject to production variations. OPERATING AND SERVICE MESSAGES DISPLAYED ON THE ELECTRONIC OPERATING PANEL MAY VARY FROM WHAT IS SHOWN IN THE OPERATOR'S MANUAL. SHOULD THIS OCCUR ADHERE TO THE LATEST INSTRUCTION ON THE ELECTRONIC OPERATING PANEL.

Dimensions and weights are approximate only and the illustrations do not necessarily show the machine in standard condition. For exact information about any particular machine, please consult your dealer.

EC DECLARATION OF CONFORMITY DOCUMENT

Clause of 2006/42/EC Annex II	BG	CS	DA	DE	EL	EN	ES	ET	FI	FR	HR	HU	IT	LT	LV	NL	NO	PL	PT	RO	SK	SL	BV	TR	
1.A.1	Декларация за съответствие ЕС съгласно Директивата 2006/42/ЕО и 2004/108/ЕО	Prohlášení o shodě EU podle směrnice 2006/42/EU a 2004/108/ES	EU-overensstemmelseserklæring ifølge direktivene 2006/42/EF & 2004/108/EF	EG – Konformitätserklärung laut Richtlinien 2006/42/EG & 2004/108/EG	Α Δήλωση Συμμόρφωσης ΕΚ σύμφωνα με τις Οδηγίες 2006/42/ΕΚ & 2004/108/ΕΚ	DECLARATION OF CONFORMITY According to Directives 2006/42/EC & 2004/108/EC	Declaración CE de conformidad de acuerdo con las Directivas 2006/42/CE & 2004/108/CE	EU vastavõtmise deklaratsioon vastavalt direktiividele 2006/42/EÜ ja 2004/108/EÜ	EY-vaatimustenmukaistusvakuutus Direktiivien 2006/42/EY ja 2004/108/EY mukaisesti	Declaration de conformité CE selon les Directives 2006/42/CE et 2004/108/CE	DECLARATION OF CONFORMITY According to Directives 2006/42/EC & 2004/108/EC	ÉK Megfelelőségi nyilatkozat az 2006/42/EK és 2004/108/EK irányelvek alapján	Dichiarazione CE di conformità secondo le Direttive 2006/42/CE e 2004/108/CE	EB atitūstības deklarācija atbilstoši direktīvai 2006/42/EĻ un 2004/108/EĻ	EK atbilstības deklarācija atbilstoši direktīvai 2006/42/EK un 2004/108/EK	EG Conformiteitsverklaring overeenkomstig Richtlijnen 2006/42/EG & 2004/108/EG	EC Samsvareklæring i henhold til Direktiv 2006/42/EC & 2004/108/EC	Deklaracja zgodności WE zgodnie z dyrektywami 2006/42/EC i 2004/108/EC	Declaração de conformidade CE segundo as Diretivas 2006/42/CE e 2004/108/CE	Declaratia de Conformitate CE in conformitate cu Directiva 2006/42/CE si 2004/108/CE	ES výhlášení o shodě podle směrnice 2006/42/ES a 2004/108/ES	EU-överensstemmelseerklæring ifølge direktivene 2006/42/EF & 2004/108/EF	EK atbilstības deklarācija atbilstoši direktīvai 2006/42/EK un 2004/108/EK	EG-förklarung om överensstemmelse enligt direktiv 2006/42/EG och 2004/108/EG	AT Üyumlük Beyanı 2006/42/AT & 2004/108/AT Direktiflerine Göre
1.A.2	представителите от Антон Вермоуден, Leon Claystraat 3A, B8210 Zoelgem (Belgium)	zástupce Anton Vermoulen, Leon Claystraat 3A, B8210 Zoelgem (Belgium)	repræsentant af Anton Vermoulen, Leon Claystraat 3A, B8210 Zoelgem (Belgium)	vertreter durch Anton Vermoulen, Leon Claystraat 3A, B8210 Zoelgem (Belgium)	επιφοροποιουμενο στο Αντον Βερμουδεν, Leon Claystraat 3A, B8210 Zoelgem (Belgium)	represented by Anton Vermoulen, Leon Claystraat 3A, B8210 Zoelgem (Belgium)	representado por Anton Vermoulen, Leon Claystraat 3A, B8210 Zoelgem (Belgium)	esindajalgat Anton Vermoulen, Leon Claystraat 3A, B8210 Zoelgem (Belgium)	edustajattaranne Anton Vermoulen, Leon Claystraat 3A, B8210 Zoelgem (Belgium)	Représenté par Anton Vermoulen, Leon Claystraat 3A, B8210 Zoelgem (Belgium)	represented by Anton Vermoulen, Leon Claystraat 3A, B8210 Zoelgem (Belgium)	aktualizator Anton Vermoulen, Leon Claystraat 3A, B8210 Zoelgem (Belgium)	representat de Anton Vermoulen, Leon Claystraat 3A, B8210 Zoelgem (Belgium)	atstovėjai Anton Vermoulen, Leon Claystraat 3A, B8210 Zoelgem (Belgium)	Anton Vermoulen, Leon Claystraat 3A, B8210 Zoelgem (Belgium)	vertegenwoordigd door Anton Vermoulen, Leon Claystraat 3A, B8210 Zoelgem (Belgium)	representant av Anton Vermoulen, Leon Claystraat 3A, B8210 Zoelgem (Belgium)	aktualizator Anton Vermoulen, Leon Claystraat 3A, B8210 Zoelgem (Belgium)	aktualizator Anton Vermoulen, Leon Claystraat 3A, B8210 Zoelgem (Belgium)	representado por Anton Vermoulen, Leon Claystraat 3A, B8210 Zoelgem (Belgium)	zástupce Anton Vermoulen, Leon Claystraat 3A, B8210 Zoelgem (Belgium)	EU-överensstemmelseerklæring ifølge direktivene 2006/42/EF & 2004/108/EF	EK atbilstības deklarācija atbilstoši direktīvai 2006/42/EK un 2004/108/EK	EG-förklarung om överensstemmelse enligt direktiv 2006/42/EG och 2004/108/EG	AT Üyumlük Beyanı 2006/42/AT & 2004/108/AT Direktiflerine Göre
1.A.3	дипломатичен, полевият машина отговорност, че продуктът: Конструктивна машина / Търговска марка и модел: [2] / Обозначение: [3] / Тип: [4] / Серийен номер: [5]	profesionalno, poljski odgovornost, že proizvod: Konstrukcijska mašina / Trgovska marka in model: [2] / Oznaka: [3] / Tip: [4] / Vrlovalni štoli: [5]	Zusätzliches Wort / Obchodní název a model: [2] / Označení: [3] / Typ: [4] / Výrobní číslo: [5]	erklærer herved at nedennævnte beskrevet produkt: Landbrugsmaskine / Kommercielt navn og Model: [2] / Benævnelser: [3] / Type: [4] / Serienummer: [5]	erklærer herved at nedennævnte beskrevet produkt: Landbrugsmaskine / Handelsbezeichnung und Modell: [2] / Funktionen: [3] / Typ: [4] / Serienummer: [5]	επιφοροποιουμενο στο τροποποιηθενο με το παρακατω: Γεωργιαστικη μηχανη / Εμπορικη ονομασια και μοντελο: [2] / Ονομα: [3] / Τυπος: [4] / Τυπος: [4] / Τυπος: [4] / Τυπος: [4]	declare under our sole responsibility, that the product: Agricultural machine / Commercial Name and Model: [2] / Denomination: [3] / Type: [4] / Serial Number: [5]	declararions, bajo nuestra exclusiva responsabilidad, que el producto: Máquina agrícola / Denominación Comercial e Modelo: [2] / Descripción: [3] / Tipo: [4] / Número de serie: [5]	Armlidat, kura atbildīgas, ir: boods: Poljumsaules mašīna / Komercijais nosaukums un modeļi: [2] / Nominācija: [3] / Tipi: [4] / Sērijnumurs: [5]	epäkuulijamme omanlaista vastuuttamme, että tuote: Maatalouskone / Kaupallinen nimi ja malli: [2] / Yleisnimi: [3] / Tyyppi: [4] / Sarjainumero: [5]	deklarons sous notre seule responsabilité, que le produit: Machine agricole / Dénomination Commerciale et Modèle: [2] / Fonction: [3] / Fondon: [3] / Type: [4] / Numéro de série: [5]	declared under our sole responsibility, that the product: Agricultural machine / Commercial Name and Model: [2] / Denomination: [3] / Type: [4] / Serial Number: [5]	nyilatkozom, hogy a termék: Mezőgazdasági gép / Kereskedelmi név, modellje: [2] / Megnevezés: [3] / Típus: [4] / Sorozatszám: [5]	deklararion, sotto nostra esclusiva responsabilità, che il prodotto: Macchina agricola / Denominazione commerciale e Modello: [2] / Descrizione: [3] / Tipo: [4] / Numero di serie: [5]	atbilstošas deklarācija, ka produkts: Lauksaimniecības mašīna / Komercijais nosaukums un modeļi: [2] / Nosaukums: [3] / Tipi: [4] / Sērijas numurs: [5]	er viertegenwoordigd atbilstendepkin, dat het product: Landbouwmachine / Landbouwmachine / Commerciële benaming en Model: [2] / Functie: [3] / Type: [4] / Serienummer: [5]	erklærer engi i ansvarforordning, dat het produkt: Landbouwmachine / Landbouwmachine / Commerciële benaming en Model: [2] / Functie: [3] / Type: [4] / Serienummer: [5]	erklærer som eneransvarlig produkt: Landbouwmachine / Landbouwmachine / Commerciële benaming en Model: [2] / Functie: [3] / Type: [4] / Serienummer: [5]	otwiazczam na swojej wylozono odpowiedzialnosci, ze produkt: Maszyna rolnicza / Marka i model: [2] / Nazwa: [3] / Typ: [4] / Numer seryjny: [5]	declaração de conformidade CE segundo as Diretivas 2006/42/CE e 2004/108/CE	Declaratia de Conformitate CE in conformitate cu Directiva 2006/42/CE si 2004/108/CE	ES výhlášení o shodě podle směrnice 2006/42/ES a 2004/108/ES	EK atbilstības deklarācija atbilstoši direktīvai 2006/42/EK un 2004/108/EK	EG-förklarung om överensstemmelse enligt direktiv 2006/42/EG och 2004/108/EG	AT Üyumlük Beyanı 2006/42/AT & 2004/108/AT Direktiflerine Göre
1.A.4	as a que se refere esta declaração, está em conformidade com as disposições das Directivas 2006/42/CE e 2004/108/CE, modificadas por [6]	na koje se referira presente declaracione conforma a las disposiciones de las Directivas 2006/42/CE & 2004/108/CE, modificadas por [6]	na koho se tolo vyhlášení vztahuje, odpovídá všem platným ustanovením směrnice 2006/42/ES a 2004/108/ES, změněnými v [6]	auf das sich diese Erklärung bezieht, allen einschlägigen Bestimmungen dieser Richtlinien 2006/42/EG und 2004/108/EG entspricht, abgeändert durch [6]	το οποίο αφορά αυτήν την δήλωση συμμόρφωσης, είναι σύμφωνη με τις διατάξεις των οδηγιών 2006/42/ΕΚ & 2004/108/ΕΚ, τροποποιημένης σε [6]	as a que se refere esta declaração, está em conformidade com as disposições das Directivas 2006/42/CE e 2004/108/CE, modificadas por [6]	as a que se refere esta declaração, está em conformidade com as disposições das Directivas 2006/42/CE e 2004/108/CE, modificadas por [6]	as a que se refere esta declaración, está em conformidade con las disposiciones de las Directivas 2006/42/CE & 2004/108/CE, modificadas por [6]	na koho se tolo vyhlášení vztahuje, odpovídá všem platným ustanovením směrnice 2006/42/ES a 2004/108/ES, změněnými v [6]	na koto se tolo vyhlášení vztahuje, odpovídá všem platným ustanovením směrnice 2006/42/EF & 2004/108/EF, změněnými v [6]	as a que se refere esta declaração, está em conformidade com as disposições das Directivas 2006/42/CE e 2004/108/CE, modificadas por [6]	as a que se refere esta declaração, está em conformidade com as disposições das Directivas 2006/42/CE e 2004/108/CE, modificadas por [6]	as a que se refere esta declaração, está em conformidade com as disposições das Directivas 2006/42/CE e 2004/108/CE, modificadas por [6]	as a que se refere esta declaración, está em conformidade con las disposiciones de las Directivas 2006/42/CE & 2004/108/CE, modificadas por [6]	na koto se tolo vyhlášení vztahuje, odpovídá všem platným ustanovením směrnice 2006/42/EF & 2004/108/EF, změněnými v [6]	na koto se tolo vyhlášení vztahuje, odpovídá všem platným ustanovením směrnice 2006/42/EF & 2004/108/EF, změněnými v [6]	as a que se refere esta declaração, está em conformidade com as disposições das Directivas 2006/42/CE e 2004/108/CE, modificadas por [6]	as a que se refere esta declaração, está em conformidade com as disposições das Directivas 2006/42/CE e 2004/108/CE, modificadas por [6]	as a que se refere esta declaração, está em conformidade com as disposições das Directivas 2006/42/CE e 2004/108/CE, modificadas por [6]	as a que se refere esta declaração, está em conformidade com as disposições das Directivas 2006/42/CE e 2004/108/CE, modificadas por [6]	na koto se tolo vyhlášení vztahuje, odpovídá všem platným ustanovením směrnice 2006/42/EF & 2004/108/EF, změněnými v [6]	EK atbilstības deklarācija atbilstoši direktīvai 2006/42/EK un 2004/108/EK	EG-förklarung om överensstemmelse enligt direktiv 2006/42/EG och 2004/108/EG	AT Üyumlük Beyanı 2006/42/AT & 2004/108/AT Direktiflerine Göre	
1.A.7	Para la relevante implementación de las Directivas 2006/42/CE y 2004/108/CE, se han aplicado las siguientes normas (armonizadas):	Para la implementación de las Directivas se han aplicado las siguientes normativas (armonizadas):	Direktivy sa také uplatňujú (harmonizované) normy:	Zur sachgerechten Umsetzung der in den EG-Richtlinien enthaltenen Forderungen werden folgende (abgeänderte) Normen herangezogen:	Για η σχετική υλοποίηση των οδηγιών 2006/42/ΕΚ & 2004/108/ΕΚ, έχουν εφαρμοστεί οι ακόλουθοι (τροποποιημένοι) πρότυποι:	For the relevant implementation of the Directives, the following (harmonized) standards have been applied:	Para a implementação de las Directivas, se han aplicado las siguientes normativas (armonizadas):	Skaiti (gyvendinti) direktyvą nuostatius buvo taikyti (taikytiniai) standartai:	EY-direktiivissä mainittujen vaatimusten tähteyttä on toteutettu (harmonisoituneita) standardeja käyttäen:	Pour mettre en pratique les prescriptions harmonisées des Directives, les normes suivantes (harmonisées) ont été appliquées:	For relevant implementation of the relevant Directives, the following (harmonized) standards have been applied:	As a que se refere esta declaração, está em conformidade com as disposições das Directivas 2006/42/CE e 2004/108/CE, modificadas por [6]	Per l'implementazione delle disposizioni delle Direttive, sono state applicate le seguenti norme (armonizzate):	Skaiti (gyvendinti) direktyvą nuostatius buvo taikyti (taikytiniai) standartai:	La atbilstoši realizuoti direktyvų nuostatus, taikyti (taikytiniai) standartai:	Plats en handtekening van de gemachtigde persoon [8]	For relevant implementation of the relevant Directives, the following (harmonized) standards have been applied:	As a que se refere esta declaração, está em conformidade com as disposições das Directivas 2006/42/CE e 2004/108/CE, modificadas por [6]	As a que se refere esta declaração, está em conformidade com as disposições das Directivas 2006/42/CE e 2004/108/CE, modificadas por [6]	As a que se refere esta declaração, está em conformidade com as disposições das Directivas 2006/42/CE e 2004/108/CE, modificadas por [6]	As a que se refere esta declaração, está em conformidade com as disposições das Directivas 2006/42/CE e 2004/108/CE, modificadas por [6]	As a que se refere esta declaração, está em conformidade com as disposições das Directivas 2006/42/CE e 2004/108/CE, modificadas por [6]	EK atbilstības deklarācija atbilstoši direktīvai 2006/42/EK un 2004/108/EK	EG-förklarung om överensstemmelse enligt direktiv 2006/42/EG och 2004/108/EG	AT Üyumlük Beyanı 2006/42/AT & 2004/108/AT Direktiflerine Göre
1.A.9	Local e data de declaração: [7]	Nome e assinatura da pessoa autorizada: [8]	Vi, [1]	Wir, [1]	Επί, [1]	Name and signature of authorized person: [8]	Nombre y firma de la persona autorizada: [8]	Vi, [1]	Me, [1]	Nous, [1]	Name and signature of authorized person: [8]	Államnév és aláírás az engedélyezett személytől: [8]	Nome e assinatura da pessoa autorizada: [8]	Vi, [1]	Me, [1]	Wij, [1]	Vi, [1]	Nous, [1]	Firma [1]	Nome e assinatura da pessoa autorizada: [8]	Vi, [1]	Wir, [1]	Επί, [1]	AT Üyumlük Beyanı 2006/42/AT & 2004/108/AT Direktiflerine Göre	
1.A.10	Logo e indirizzo del responsabile della [8]	Logo e indirizzo del responsabile della [8]	Logo e indirizzo del responsabile della [8]	Logo e indirizzo del responsabile della [8]	Logo e indirizzo del responsabile della [8]	Logo e indirizzo del responsabile della [8]	Logo e indirizzo del responsabile della [8]	Logo e indirizzo del responsabile della [8]	Logo e indirizzo del responsabile della [8]	Logo e indirizzo del responsabile della [8]	Logo e indirizzo del responsabile della [8]	Logo e indirizzo del responsabile della [8]	Logo e indirizzo del responsabile della [8]	Logo e indirizzo del responsabile della [8]	Logo e indirizzo del responsabile della [8]	Logo e indirizzo del responsabile della [8]	Logo e indirizzo del responsabile della [8]	Logo e indirizzo del responsabile della [8]	Logo e indirizzo del responsabile della [8]	Logo e indirizzo del responsabile della [8]	Logo e indirizzo del responsabile della [8]	Logo e indirizzo del responsabile della [8]	Logo e indirizzo del responsabile della [8]	Logo e indirizzo del responsabile della [8]	Logo e indirizzo del responsabile della [8]



CNH America LLC
Racine WI 53404
(U.S.A.)

NEW HOLLAND

On page 1-4 is provided copy of the "EC" Declaration of Conformity (EC Declaration of Conformity according to 2006/42/EC).

The EC Declaration of Conformity is the manufacturer's declaration about equipment compliance to relevant EU provisions.

Please keep the original document in a safe place. Local authorities may require you to show this document in order to assure compliance of your equipment.

Translation of this declaration in your own country language is provided on the original document.

For your better and easier understanding of the document you'll find original text reproduced hereafter together with some notes.

Clause of 2006/42/EC Annex I*1	<p style="text-align: center;">EN</p> <p style="text-align: center;">EC Declaration of Conformity</p> <p style="text-align: center;">According to Directives 2006/42/EC & 2004/108/EC</p>		 <p style="text-align: center;">CNH America LLC Racine WI 53404 (U.S.A.)</p>
1.A.1	We, [1]	[1]	CNH America LLC
1.A.2	represented by Antoon Vermeulen, Leon Claeystraat 3A, B8210 Zedelgem (Belgium)		
1.A.3	declare under our sole responsibility, that the product: Agricultural machine Commercial Name and Model: [2] Denomination: [3] Type: [4] Serial number: [5]	[2] [3] [4] [5]	New Holland T9030, T9040, T9050, T9060 Tractor F2
1.A.4	to which this declaration relates, fulfills all the relevant provisions of Directives 2006/42/EC & 2004/108/EC, amended by: [6]	[6]
1.A.7	For the relevant implementation of the provisions of the Directives, the following (harmonised) standards have been applied: <ul style="list-style-type: none"> • EN ISO 4254-1 • EN 15811 • EN ISO 14982 • Other standards: see Operator's Manual 		
1.A.9	Place and date of the declaration: [7]	[7]
1.A.10	Name and signature of authorized person: [8]	[8]

Effective 29-December-09

HEALTH AND SAFETY RELATED STANDARDS APPLIED TO YOUR MACHINE

- Tractor Safety according to **ISO 26322-1**
- FOPS level on this tractor is certified according to **OECD Code 10**
- Cab is certified Category 2 according to **EN 15695-1**
- Noise Emission Levels are rated according to **77/311/EEC**
- Vibration Levels are rated according to **78/764/EEC**
- ROPS Protection inside cab is certified according to **EN 15694**



NOTE: Refer to further explanation and details on above mentioned standards within this manual.

GENERAL TABLE OF CONTENTS

1-TO THE OWNER	1
T9000 SERIES TRACTORS	1
GENERAL INFORMATION	2
TRACTOR NOISE LEVEL INFORMATION	5
TRACTOR VIBRATION LEVEL INFORMATION	6
TRACTOR ORIENTATION	7
MACHINE MAIN COMPONENTS	8
PRODUCT IDENTIFICATION AND SERIAL NUMBERS	9
CHEMICAL TANK MOUNTING	13
BUSINESS BAND RADIO READY (IF EQUIPPED)	14
2-SAFETY/DECALS	16
SAFETY	16
PERSONAL SAFETY	19
INSTRUCTIONAL SEAT SAFETY	19
ROLL-OVER AND TIP-OVER HAZARDS	20
MAINTENANCE SAFETY	21
FIRE SAFETY	22
BATTERY SAFETY	23
MACHINE OPERATION SAFETY	23
HAZARDOUS CHEMICALS	24
SAFETY DECALS	26
ARTICULATION CYLINDER LOCKING BLOCKS	34
MOUNTING AND DISMOUNTING THE TRACTOR	34
ROPS (ROLLOVER PROTECTIVE STRUCTURE)	35
CAB CATEGORY	36
CLEANING CAB WINDOWS	37
RIGHT-HAND SERVICE WINDOW	37
INTERIOR REAR VIEW MIRROR	37
SEAT BELTS	38
TRACTOR WARNING LAMPS AND SMV SYMBOL	40
IMPLEMENT WARNING LAMPS	41
SAFETY CHAIN	42
3-OPERATING CONTROLS	43
TRACTOR ACCESS	43
CAB POWER CUT-OFF SWITCH	45
OPERATOR'S SEAT WITH AIR SUSPENSION	46
INSTRUCTIONAL SEAT (IF EQUIPPED)	48
STEERING COLUMN CONTROLS	50
FOOT PEDALS	51
CENTER CONSOLE CONTROLS	52
RIGHT-HAND ARMREST CONSOLE CONTROLS	53
RIGHT-HAND ARMREST CONTROL CONSOLE	54
ARMREST CONSOLE CONTROLS	61
6TH-7TH/MEGAFLOW ELECTRIC REMOTE VALVES (IF EQUIPPED)	63
AUTO GUIDANCE ROADING SWITCH (IF EQUIPPED)	63
UPPER CONSOLE CONTROLS	64
MP3 PLAYER/SATELLITE RADIO JACK	67
HVAC CONTROL SYSTEM	68
AUTOMATIC TEMPERATURE CONTROL OPERATION	71
POWER MIRROR CONTROL (IF EQUIPPED)	72

4-INSTRUMENTATION	76
ROPS POST INSTRUMENT CLUSTER OVERVIEW	76
ICON DESCRIPTION	82
PROGRAMMING THE DISPLAY MONITOR	84
OLD HOURS	91
PROGRAM ADJUST MENU	92
WARNING FAULT DISPLAYS	96
INSTRUMENTATION CLUSTER OPERATION	103
DIAGNOSTIC DISPLAY	119
5-OPERATING INSTRUCTIONS	120
BEFORE STARTING THE ENGINE	120
SEAT BELTS	121
STEERING COLUMN ADJUSTMENT	122
STARTING THE ENGINE	123
COLD WEATHER STARTING	125
STARTING FLUID CONTAINER REPLACEMENT (T9060 ONLY, IF EQUIPPED)	127
STOPPING THE ENGINE	128
COLD TEMPERATURE OPERATION	129
TOWING THE TRACTOR	132
TRANSPORTING THE TRACTOR	134
POWERSHIFT TRANSMISSION OPERATION (IF EQUIPPED)	135
CONSTANT GROUND SPEED OPERATION	140
DIFFERENTIAL LOCK (IF EQUIPPED)	151
CONSTANT ENGINE SPEED OPERATION (IF EQUIPPED)	152
6-FIELD OPERATION	153
POWER TAKEOFF (IF EQUIPPED)	153
OPERATING THE POWER TAKEOFF (PTO)	156
STANDARD DRAWBAR	158
THREE POINT HITCH PREPARATION	162
HITCH COUPLER - CATEGORY III OR IV-N	167
HITCH OPERATION	171
RAISING AND LOWERING THE HITCH	172
REMOTE HYDRAULICS	184
AUXILIARY IMPLEMENT POWER CONNECTIONS	197
7-IN-FIELD PERFORMANCE	201
TRACTOR BALLAST	201
FRONT AND REAR SUITCASE WEIGHTS	207
WHEEL WEIGHTS	210
WHEEL WEIGHT BOLT TORQUE	211
TIRE AND RIM SERVICE	212
TIRE PRESSURE FOR MAXIMUM TIRE LOAD AT RATED INFLATION	216
TRACTOR JACKING POINTS	219
WHEEL BOLT TORQUES	221
SCRAPER OPERATING PROCEDURES	229

8-LUBRICATION/FILTERS/FLUID/MAINTENANCE	231
LUBRICATION AND MAINTENANCE	231
LUBRICANTS AND CAPACITIES	231
ENGINE LUBRICATION	232
LUBRICATION AND MAINTENANCE CHART	234
BIODIESEL FUEL	238
GRILLE AND HOOD ACCESS	239
AIR INDUCTION SYSTEM	267
PRESSURE COOLING SYSTEM	295
SCA SERVICE REQUIREMENTS (T9060 ONLY)	295
DISASSEMBLY, DECOMMISSIONING OR SCRAPPING THE MACHINE	297
9-ELECTRICAL SYSTEM	299
SPECIFICATIONS	299
FUSES	299
GENERAL SERVICE INFORMATION	304
10-SPECIFICATIONS	305
GENERAL SPECIFICATIONS	305
TRACTOR WEIGHTS	308
APPROXIMATE OVERALL MEASUREMENTS	311
11-DETAIL INDEX	313

T9000 SERIES TRACTORS

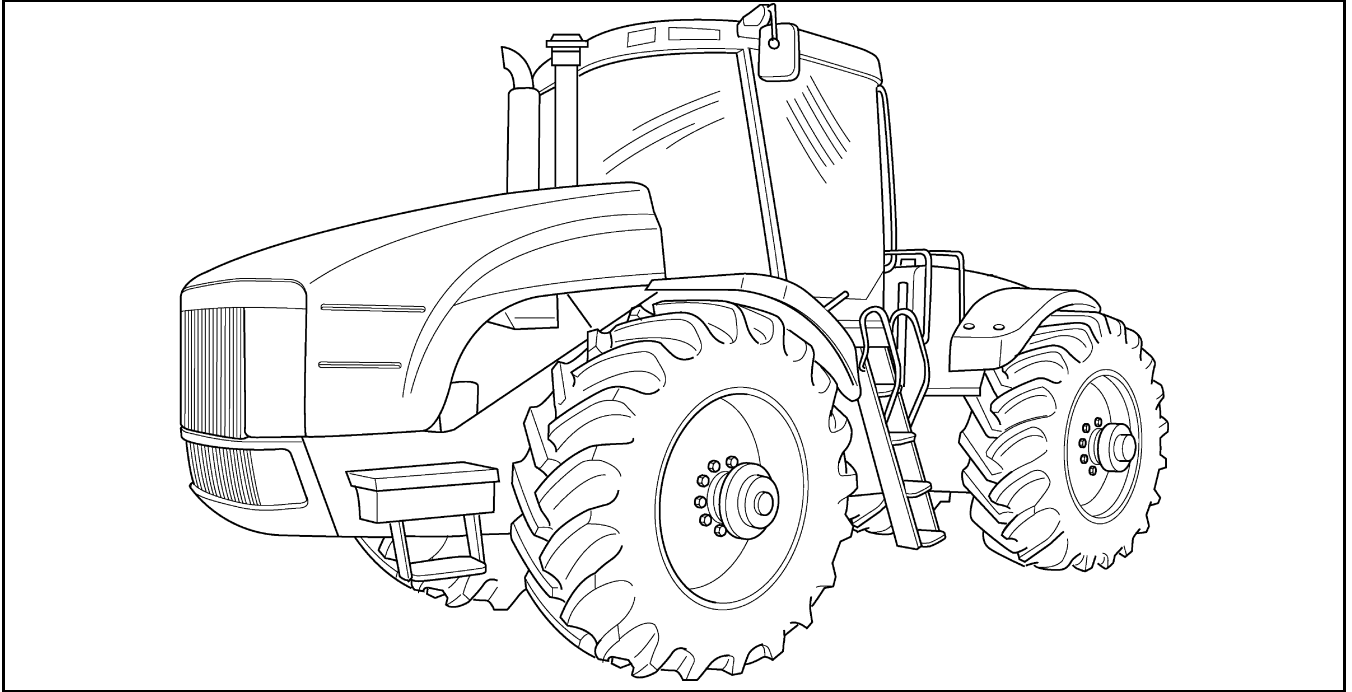

MK01G135A

NOTE: *When you are in the Tractor seat looking forward, the right and left side of the tractor are the same as your right hand and left hand.*



522L94

CNH America, LLC
Racine, WI 53404 U.S.A.

DEALER'S STAMP

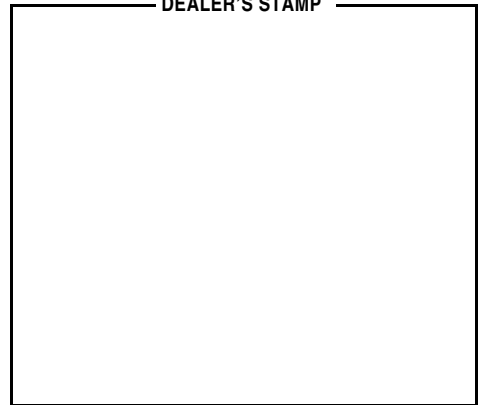

HEALTH AND SAFETY RELATED STANDARDS APPLIED TO YOUR TRACTOR

Tractor Safety according to **ISO 26322-1**

FOPS level on this Ag version tractor is certified according to **OECD Code 10**

Cab is certified Category 2 according to **EN 15695-1**

Noise Emission Levels are rated according to **77/311/EEC and 74/151/EEC**

Vibration Levels are rated according to **78/764/EEC**

Instruction Seat Protection inside ROPS cab is certified according to **EN 15694**

Safety Signs and hazard pictorials are certified according to **ISO 11684**

NOTE: *Refer to further explanation and details on above mentioned standards within this manual.*

GENERAL INFORMATION

Introduction to this Manual

This manual gives information for use of your T9000 Series Tractor, as intended and under the conditions foreseen by the manufacturer during normal operation and routine service and maintenance.

The manual is divided into ten sections as outlined in the General Table of Contents Page(s). Refer to the Detail Index at the end of this manual for locating specific items about your tractor.

Scope and Required Training Level

This manual gives information for use of your tractor, as intended and under the conditions foreseen by the manufacturer during normal operation and routine service and maintenance.

Normal operation consists of use of the tractor for the purpose intended by the manufacturer by an operator that is familiar with the tractor and the mounted or towed equipment, and who is complying with the information for operation and safe practices, as specified by the manufacturer in this manual and by the signs on the tractor and the equipment.

Normal operation includes such actions as the preparation and storage of the tractor, swinging components into work position and vice versa, adding or removing ballast, picking up and setting off mounted or towed equipment, and the adjustment and setting of the tractor and equipment for the specific condition of the field and/or the crop.

Routine service and maintenance consists of activities that must be performed daily in order to maintain proper tractor function by an owner/operator who is familiar with tractor characteristics, and who is complying with the information for routine service and safe practices, as specified by the manufacturer in this manual and by the decals on the tractor.

Routine service includes activities such as fueling, cleaning, washing, topping up fluid levels, greasing, and replacing consumable articles such as lamp bulbs.

Periodic service and maintenance are those actions which must be performed at regularly defined intervals to maintain proper tractor function by an owner/operator who is familiar with tractor characteristics, and who is complying with the information on periodic service and safe practices in this manual and in the decals on the tractor.

Periodic service and maintenance includes such actions as checking, cleaning and changing air filters, changing engine oil and filters, changing transmission oil and filters, changing axle and wheel hub fluids, changing coolant, etc.

Some actions in the periodic service and maintenance chart are beyond the knowledge and skills of the owner/operator: for example, engine valve adjustment, fuel injector nozzles. For these actions, the manual instructs the owner/operator to have the action performed by their authorized dealer.

This manual does not contain all the information related to periodical service, converting and repairs to be carried out professional service personnel. These actions require special facilities, technical skills, and/or tools which are not supplied with the machine.

Converting is changing the tractor configuration for a specific crop or soil condition and requires rebuilding or adding components to the vehicle: for example, installation of dual wheels. Repairing is the disassembly and assembly of the tractor to restore proper operation after a component failure or degradation of performance.

Read this manual before you start the engine or operate this tractor. If any information in this manual is not understood, or if you need more information or assistance, contact your dealer.

All persons training to operate, or who will be operating this tractor, should be old enough to possess a valid local vehicle operating permit (or other applicable local age requirement) and must have demonstrated the ability to operate and service the tractor correctly and safely.

Before permitting a new operator on this machine make sure:

1. That the operator is qualified to operate the machine correctly and safely.
2. That the operator has read and understood the instructions given in this manual.

Statement of Tractor Intended Use

The T9000 Series Tractor, with standard equipment and authorized attachments, is intended to be used for customary farming, land leveling and related agriculture operations. This tractor is not intended for forestry use or for use with loaders. The cab on this tractor does not offer sufficient protection for forestry work.

Installation of utility (dozer) blades, tile plows, front loaders or push bars on the tractor is not approved. Any tractor damage resulting from the installation and/or use of such equipment is not covered by the tractor warranty.

DO NOT use this machine for any purpose or in any manner other than as described in the manual, decals or other product safety information provide with the machine. These materials define the machine's intended use.

If your tractor requires replacement parts, do not use unauthorized parts or substitute materials. New Holland dealers stock New Holland approved service parts and have technicians with special training that know the best methods of repair and maintenance for your tractor.

ATTENTION: *The engine and fuel system on your machine is designed and built to government emissions standards. Tampering by dealer, customers, operators and users is **strictly prohibited by law**. Failure to comply could result in government fines, rework charges, invalid warranty, legal action and possible confiscation of the machine until rework to original condition is completed. Engine service and/or repairs must be done by a certified technician only!*

ALWAYS:

- Always wear the seat belt.
- Use only matching and compatible equipment
- Respect dynamic stability limits (speed, slope, adherence, abrupt cornering....)
- Download only approved/recommended software.

Operator Manual Storage Compartment

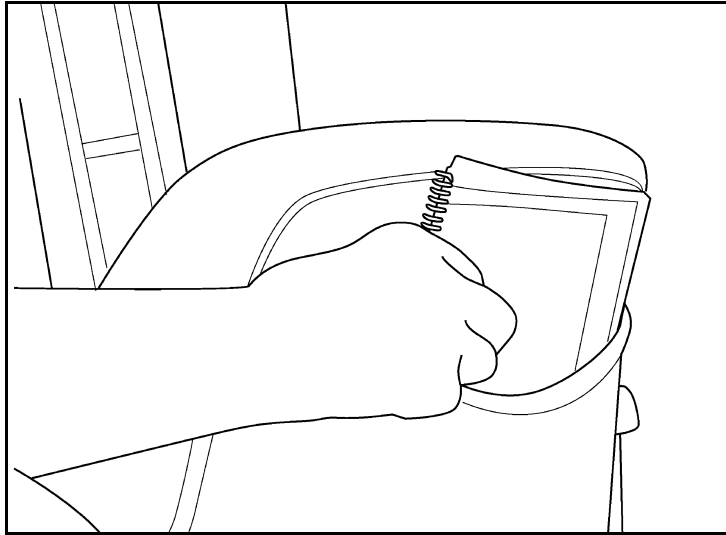

MK99H025

DO NOT permit anyone to operate or service this tractor until you or other operators have read this manual. The Operator's Manual is a part of your tractor and must be available to all operators.

Make sure the manual is complete and in good condition. Store the Operator's Manual and other important tractor information in the storage compartment provided on the rear side of the seat backrest.

Official Documents

A "EC" declaration of conformity

IMPORTANT: *An original of this "EC" declaration is supplied with each machine and must be kept carefully by the owner.*

IMPORTANT: *The official documents supplied with the machine must be kept by the owner so as to be able to present them to any inspecting authority which may request them.*

Thank you so much for reading.
Please click the “Buy Now!”
button below to download the
complete manual.



After you pay.

You can download the most
perfect and complete manual in
the world immediately.

Our support email:

ebooklibonline@outlook.com