

OPERATOR'S MANUAL

Boomer 40 Boomer 50 Compact Tractor

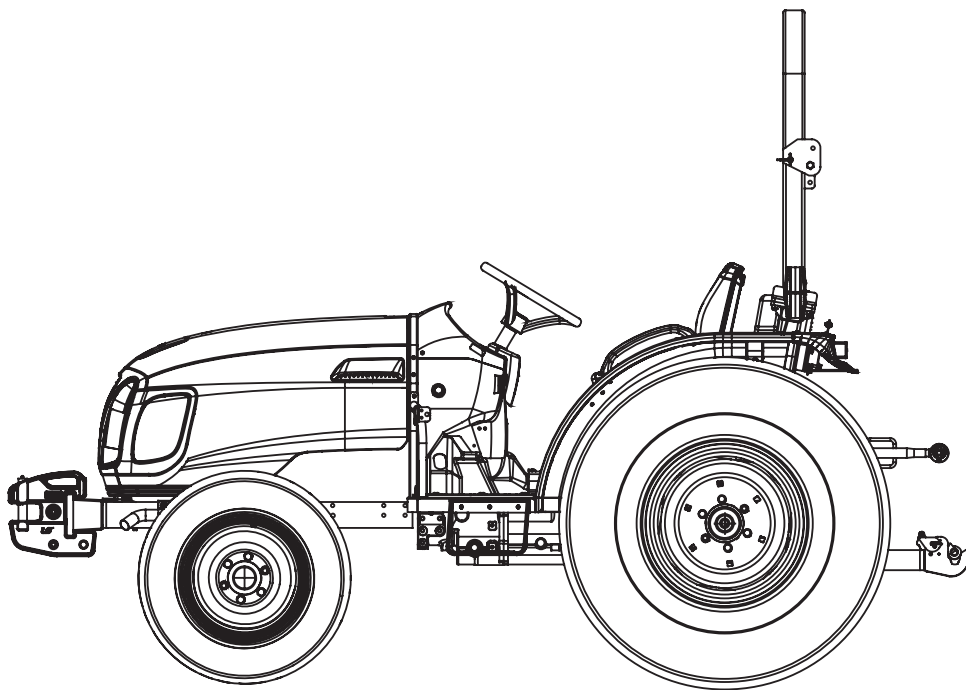

Part number 84471929
2nd edition English
April 2011
Replaces part number 84275459



Contents

1 GENERAL INFORMATION

Note to the Owner	1-1
Foreword Ecology and the Environment	1-2
General specification - Biodiesel Fuels	1-3
Proposition 65	1-4
Advice	1-5
FRAME AND CAB - Torque - Minimum Tightening Torques for Normal Assembly	1-6
Product identification	1-9

2 SAFETY INFORMATION

Precautionary statements and signal word definitions	2-1
Safety rules	2-2
Personal safety	2-7
Safety rules	2-8
ROPS - Personal safety - Roll-over protective structure	2-10
Safety decals	2-11
INSTRUCTIONAL DECALS	2-17
International symbols	2-20

3 CONTROLS/INSTRUMENTS

OPERATOR'S SEAT

Seat belt	3-1
Seat controls	3-1
Roll over protective structure	3-2

FORWARD CONTROLS

Instrument panel - Identification	3-4
Cruise control	3-6
Transmission shuttle shift lever	3-6
Clutch pedal	3-7
Brake pedals	3-7
Foot throttle pedal	3-8
Hand throttle lever	3-8
Horn switch	3-8
PTO switch	3-9
Key switch	3-10
Differential lock pedal	3-11
HST foot pedals	3-12
Tilt steering lever	3-12
Multifunction light switch	3-13

LEFT-HAND SIDE CONTROLS

Transmission range lever	3-14
Park brake	3-14
Front-wheel drive lever	3-15

Mid PTO lever	3-16
---------------------	------

RIGHT-HAND SIDE CONTROLS

PRIMARY HYDRAULIC POWER SYSTEM - Dynamic description	3-17
Draft control	3-18
Rear remote control valve(s)	3-19
Two-spool control valve	3-20
Transmission main shift lever	3-21
HST transmission range lever	3-22

EXTERIOR CONTROLS

Hood release lever	3-23
--------------------------	------

4 OPERATING INSTRUCTIONS

COMMISSIONING THE UNIT

Engine break-in procedure	4-1
Power take-off (PTO) operation	4-2
Three-point linkage	4-4
Attaching three-point equipment	4-5
Extendible drawbar	4-8
Hydraulic lift rocker	4-9
HPL drop rate control valve	4-9

STARTING THE UNIT

Key switch	4-10
Cold starting aids	4-10
Starting the engine	4-11
Starting the tractor with jumper cables - Starting the tractor with jumper cables	4-14

STOPPING THE UNIT

Stopping the engine	4-15
Emergency stopping	4-16
Brakes	4-17

MOVING THE UNIT

Steering wheel adjustment	4-19
Steering operation	4-20
Transmission operation at low ambient temperatures	4-21
Hydrostatic transmission (HST) operation	4-22
16 x 16 Synchronized transmission operation	4-24

PARKING THE UNIT

AXLES, BRAKES AND STEERING - Park - Parking the tractor	4-26
---	------

5 TRANSPORT OPERATIONS

ROAD TRANSPORT

LIGHTING SYSTEM - Identification	5-1
Hazard warning light operation	5-2
Turn signal operation	5-2
Headlight/work light operation	5-3
Rear work light operation	5-4
Driving the vehicle	5-5

SHIPPING TRANSPORT

Carrying the tractor on a transporter	5-6
---	-----

RECOVERY TRANSPORT

Towing	5-6
--------------	-----

6 WORKING OPERATIONS

GENERAL INFORMATION

Tractor ballasting	6-1
Tractor ballasting weights	6-2
Liquid Ballast	6-4

7 MAINTENANCE

GENERAL INFORMATION

General Information	7-1
Safety rules Diesel Fuel	7-3
Biodiesel fuel	7-4
Basic instructions Refueling the tractor	7-5

MAINTENANCE CHART

Maintenance Chart	7-6
-------------------------	-----

LUBRICATION SYSTEM

Recommended lubricants and coolants	7-8
LUBRICATION SYSTEM - Grease - Fittings	7-9

ENGINE

LUBRICATION SYSTEM - Check - Engine	7-10
LUBRICATION SYSTEM - Change fluid Engine	7-11

FUEL AND INJECTION SYSTEM

Fuel filter system Fuel filter - Drain fluid	7-12
Fuel filter system Fuel filter - Replace	7-13

FUEL AND INJECTION SYSTEM - Bleed	7-14
Fuel injector - Bleed	7-16

AIR INTAKE SYSTEM

Air cleaner - Check	7-18
Air cleaner - Cleaning - Primary element	7-19
Air cleaner - Replace - Inner safety element	7-20

TRANSMISSION

TRANSMISSION - Check - Rear axle and hydraulic system	7-21
TRANSMISSION - Change fluid - Rear axle and hydraulic system	7-22
Oil filter - Replace - Hydraulic system	7-23
Oil filter - Replace - HST system	7-24
Clutch Adjustment	7-25
HST Neutral Adjustment	7-26

ENGINE COOLANT SYSTEM

ENGINE COOLANT SYSTEM - Check - Coolant level	7-27
Cooling system assembly - Drain fluid - And flush	7-28
Fan and drive Belt - Check	7-29
Fan and drive Belt - Adjust	7-29

ROPS

ROPS - Check - Maintenance and inspection	7-30
ROPS - Replace - Possible damage	7-31

ELECTRICAL POWER SYSTEM

Battery - Test	7-32
Alternator - Check	7-33
Fuse identification	7-34
Maxi-Fuse Replacement	7-35

LIGHTING SYSTEM

Head light - Replace	7-36
Tail/Brake light bulb replacement	7-37
Turn signal/Hazard light bulb replacement	7-38

WHEELS AND TRACKS Wheels

WHEELS AND TRACKS Wheels - Check	7-40
WHEELS AND TRACKS Wheels - Tighten	7-42
Front wheel - Check - Toe-in	7-42
Front wheel - Adjust - Toe-in	7-43

SERVICE BRAKE

SERVICE BRAKE - Adjust	7-44
------------------------------	------

FRONT AXLE

Differential - Check - Front axle differential case and final reduction gear cases	7-44
Differential - Change fluid - Front axle differential case and final reduction gear case oil	7-45

STORAGE

Storage - Storing - Tractor	7-46
Storage - Check - Tractor	7-47

8 TROUBLESHOOTING

SYMPTOM(S)

ENGINE - Troubleshooting	8-1
Clutch - Troubleshooting	8-2
SERVICE BRAKE - Troubleshooting	8-2
Hydraulic Lift System - Troubleshooting	8-2
STEERING - Troubleshooting	8-3
TRANSMISSION Hydrostatic - Troubleshooting	8-3
ELECTRICAL POWER SYSTEM - Troubleshooting	8-4

9 SPECIFICATIONS

WHEELS AND TRACKS - Tire ratios - Wheel tread settings	9-1
WHEELS AND TRACKS - Tire pressure	9-2
Liquid Ballast	9-2
ENGINE AND PTO IN - General specification	9-3
FRAME AND CAB - Dimension	9-7

10 ACCESSORIES

Optional equipment	10-1
--------------------------	------

11 FORMS AND DECLARATIONS

Delivery report - Owner Copy	11-1
Delivery report - Dealer Copy	11-3

1 - GENERAL INFORMATION

Note to the Owner

This manual contains information concerning the adjustment and maintenance of your new equipment. You have purchased a dependable machine, but only by proper care and operation can you expect to receive the performance and long service built into this equipment. Please have all operators read this manual carefully and keep it available for ready reference.

Your NEW HOLLAND AGRICULTURE dealer will instruct you in the general operation of your new equipment. (Refer to the 'Delivery Report' at the back of this manual.) Your dealer's staff of factory-trained service technicians will be glad to answer any questions that may arise regarding the operation of your machine.

Your NEW HOLLAND AGRICULTURE dealer carries a complete line of genuine NEW HOLLAND AGRICULTURE service parts. These parts are manufactured and carefully inspected to insure high quality and accurate fitting of any necessary replacement parts. Be prepared to give your dealer the model and product identification number of your new equipment when ordering parts. Locate these numbers now and record them below. Refer to the 'General Information' section of this manual for the location of the model and product identification numbers of your machine.

PLEASE RECORD THE FOLLOWING INFORMATION

Model

Product Identification Number (PIN)

Date Purchased

Engine Model

Engine PIN



This is the safety alert symbol. It is used with and without signal words to alert you to potential personal injury hazards. Obey all safety messages that follow this symbol to avoid possible death or injury.

⚠ WARNING

Illustrations in this manual may show protective shielding open or removed to better illustrate a particular feature or adjustment.

Replace all shields before operating the machine.

Failure to comply could result in death or serious injury.

W0012A

IMPROVEMENTS

CNH America LLC is continually striving to improve its products. We reserve the right to make improvements or changes when it becomes practical and possible to do so, without incurring any obligation to make changes or additions to the equipment sold previously.

Foreword Ecology and the Environment

Soil, air, and water are vital factors of agriculture and life in general. When legislation does not yet rule the treatment of some of the substances which are required by advanced technology, common sense should govern the use and disposal of products of a chemical and petrochemical nature.

NOTICE: *The following are recommendations which may be of assistance:*

- Become acquainted with and ensure that you understand the relative legislation applicable to your country.
- Where no legislation exists, obtain information from suppliers of oils, filters, batteries, fuels, antifreeze, cleaning agents, etc., with regard to their effect on man and nature and how to safely store, use and dispose of these substances.
- Agricultural consultants will, in many cases, be able to help you as well.

HELPFUL HINTS

- Avoid filling tanks using cans or inappropriate pressurized fuel delivery systems which may cause considerable spillage.
- In general, avoid skin contact with all fuels, oils, acids, solvents, etc. Most of them contain substances which may be harmful to your health.
- Modern oils contain additives. Do not burn contaminated fuels and or waste oils in ordinary heating systems.
- Avoid spillage when draining off used engine coolant mixtures, engine, gearbox and hydraulic oils, brake fluids, etc. Do not mix drained brake fluids or fuels with lubricants. Store them safely until they can be disposed of in a proper way to comply with local legislation and available resources.
- Modern coolant mixtures, i.e. antifreeze and other additives, should be replaced every two years. They should not be allowed to get into the soil but should be collected and disposed of properly.
- Do not open the air-conditioning system yourself. It contains gases which should not be released into the atmosphere. Your NEW HOLLAND AGRICULTURE dealer or air conditioning specialist has a special extractor for this purpose and will have to recharge the system properly.
- Repair any leaks or defects in the engine cooling or hydraulic system immediately.
- Do not increase the pressure in a pressurized circuit as this may lead to a component failure.
- Protect hoses during welding as penetrating weld splatter may burn a hole or weaken them, allowing the loss of oils, coolant, etc.

General specification - Biodiesel Fuels

Fatty Acid Methyl Ester Biodiesel (Biodiesel Fuel) consists of a family of fuels derived from vegetable oils treated with methyl esters.

NOTICE: *Biodiesel Fuel blends are approved for your engine only if they comply with EN14214 Specification Standards or ASTM D6751.*

NOTICE: *It is imperative that you check which blend is approved for your engine with your NEW HOLLAND AGRICULTURE dealer. Be aware that the use of Biodiesel Fuel that does not comply with the Standards mentioned above could lead to severe damage to the engine and fuel system of your machine. The use of fuels that are not approved may void NEW HOLLAND AGRICULTURE Warranty coverage.*

Biodiesel Fuel Usage Conditions

NOTICE: *The Biodiesel Fuel must meet the fuel Specification mentioned above.*

Biodiesel Fuel must be purchased from a trusted supplier that understands the product and maintains good fuel quality. Biodiesel Fuel must be pre-blended by the supplier. Mixing Biodiesel Fuels on-site can result in incorrect mixture that can lead to problems with both engine and fuel system.

Engine performance is affected by the use of Biodiesel Fuel. There may be up to **12 %** reduction in power or torque depending on the blend used.

NOTICE: *DO NOT modify the engine and/or injection pump settings to recover the reduced performance.*

The reduced power must be accepted if using any Biodiesel Fuel blend.

Some modification may be required to allow your engine to run Biodiesel Fuel. Consult your dealer for complete information on these modifications.

Biodiesel Fuel has a higher cloud point than Diesel Fuel.

NOTICE: *The use of high Biodiesel Fuel blends are not recommended in cold weather conditions.*

With Biodiesel Fuels, it may be necessary to change the engine oil, engine oil filter and fuel filter elements more frequently than with Diesel Fuels. Biodiesel Fuel can remove rust and particles from the inside of on-site fuel storage tanks that would normally adhere to the sides of the tank. Like particle deposits that commonly occur with Diesel Fuel, these particles can become trapped by the machine fuel filters, causing blockage and shortening filter life. In cold weather, this is more likely to happen. Consult your NEW HOLLAND AGRICULTURE dealer for information on cold weather operation and proper maintenance intervals when using any Biodiesel Fuel blend.

When handling Biodiesel Fuel, care must be taken not to allow water into the fuel supply. Biodiesel Fuel will actually attract moisture from the atmosphere.

Fuel tanks must be kept as full as possible to limit the amount of air and water vapors in them. It may be necessary to drain the fuel filter water tap more frequently.

Potential oxidation and stability could be a problem with the fuel stored in the machine.

NOTICE: *Machines must not be stored for more than three months with Biodiesel Fuel blends in the fuel system.*

If long storage periods are necessary, the engine must run on Diesel Fuel for 20 hours to flush the Biodiesel Fuel out of the engine fuel system prior to storage.

NOTICE: *Biodiesel Fuel must not be stored in on-site storage tanks for more than three months.*

Any spillage of Biodiesel Fuel must be cleaned up immediately before it can cause damage to the environment and the paint finish of the machine.

Before using Biodiesel Fuel blends you should consult with your dealer to receive full information about the approved blend for your machine and any detailed conditions of its usage.

NOTICE: *Be aware that not fulfilling the requirements and conditions of Biodiesel Fuel usage will void your machine's NEW HOLLAND AGRICULTURE Warranty coverage.*

Proposition 65

**CALIFORNIA
PROPOSITION 65 WARNING**

Diesel engine exhaust and some of its constituents are known to the State of California to cause cancer, birth defects, and other reproductive harm.

Battery post, terminals and related accessories contain lead and lead compounds.

Wash hands after handling

BT09A213 1

Advice

This machine was designed to power and propel itself. It is intended for agricultural use to pull or carry tractor attachments or load and move materials when equipped with a front end loader with a variety of buckets.

PROHIBITED USAGE

No parts or attachments should be fitted to this machine, which have not been released by NEW HOLLAND AGRICULTURE. They might affect machine operation, safety of the user or other people, stability or wear characteristics of the machine.

NOTICE: *Use only approved accessories and attachments designed for your machine. Consult your dealer on changes, additions or modifications that may be required for your machine. Do not make any unauthorized modifications to your machine.*

NOTICE: *DO NOT use this machine for any purpose or in any manner other than as described in the manual, decals, or other product safety information provided with the machine. These materials define the machine's intended use.*

NOTICE: *The engine and fuel system on your machine is designed and built to government emissions standards. Tampering by dealer, customers, operators and users is strictly prohibited by law. Failure to comply could result in government fines, rework charges, invalid warranty, legal action and possible confiscation of the machine until rework to original condition is completed. Engine service and/or repairs must be done by a certified technician only!*

NOTE: *All persons who will be operating this machine shall possess a valid local vehicle operating permit and/or other applicable local age work permits.*

FRAME AND CAB - Torque - Minimum Tightening Torques for Normal Assembly

METRIC NON-FLANGED HARDWARE

NOM. SIZE	CLASS 8.8 BOLT and CLASS 8 NUT		CLASS 10.9 BOLT and CLASS 10 NUT		LOCKNUT CL.8 W/CL8.8 BOLT	LOCKNUT CL.10 W/CL10.9 BOLT
	UNPLATED	PLATED W/ZnCr	UNPLATED	PLATED W/ZnCr		
M4	2.2 N·m (19 lb in)	2.9 N·m (26 lb in)	3.2 N·m (28 lb in)	4.2 N·m (37 lb in)	2 N·m (18 lb in)	2.9 N·m (26 lb in)
M5	4.5 N·m (40 lb in)	5.9 N·m (52 lb in)	6.4 N·m (57 lb in)	8.5 N·m (75 lb in)	4 N·m (36 lb in)	5.8 N·m (51 lb in)
M6	7.5 N·m (66 lb in)	10 N·m (89 lb in)	11 N·m (96 lb in)	15 N·m (128 lb in)	6.8 N·m (60 lb in)	10 N·m (89 lb in)
M8	18 N·m (163 lb in)	25 N·m (217 lb in)	26 N·m (234 lb in)	35 N·m (311 lb in)	17 N·m (151 lb in)	24 N·m (212 lb in)
M10	37 N·m (27 lb ft)	49 N·m (36 lb ft)	52 N·m (38 lb ft)	70 N·m (51 lb ft)	33 N·m (25 lb ft)	48 N·m (35 lb ft)
M12	64 N·m (47 lb ft)	85 N·m (63 lb ft)	91 N·m (67 lb ft)	121 N·m (90 lb ft)	58 N·m (43 lb ft)	83 N·m (61 lb ft)
M16	158 N·m (116 lb ft)	210 N·m (155 lb ft)	225 N·m (166 lb ft)	301 N·m (222 lb ft)	143 N·m (106 lb ft)	205 N·m (151 lb ft)
M20	319 N·m (235 lb ft)	425 N·m (313 lb ft)	440 N·m (325 lb ft)	587 N·m (433 lb ft)	290 N·m (214 lb ft)	400 N·m (295 lb ft)
M24	551 N·m (410 lb ft)	735 N·m (500 lb ft)	762 N·m (560 lb ft)	1016 N·m (750 lb ft)	501 N·m (370 lb ft)	693 N·m (510 lb ft)

NOTE: M4 through M8 hardware torque specifications are shown in pound-inches. M10 through M24 hardware torque specifications are shown in pound-feet.

IDENTIFICATION

Metric Hex head and carriage bolts, classes 5.6 and up

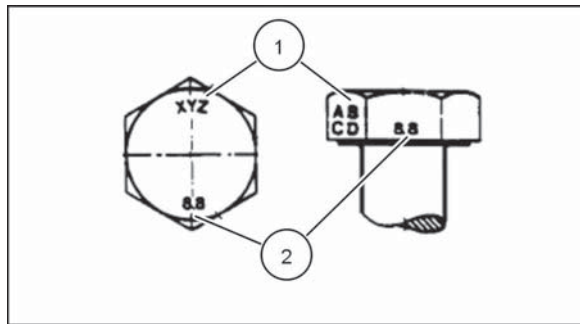

20083680 1

1. Manufacturer's Identification
2. Property Class

Metric Hex nuts and locknuts, classes 05 and up

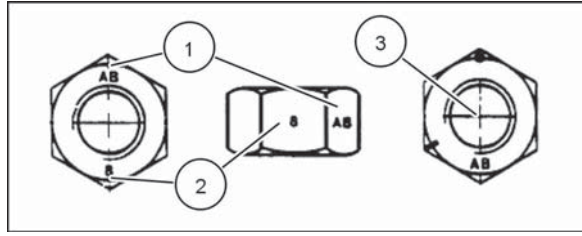

20083681 2

1. Manufacturer's Identification
2. Property Class
3. Clock Marking of Property Class and Manufacturer's Identification (Optional), i.e. marks 60 ° apart indicate Class 10 properties, and marks 120 ° apart indicate Class 8.

INCH NON-FLANGED HARDWARE

NOMINAL SIZE	SAE GRADE 5 BOLT and NUT		SAE GRADE 8 BOLT and NUT		LOCKNUT GrB W/ Gr5 BOLT	LOCKNUT GrC W/ Gr8 BOLT
	UN-PLATED or PLATED SILVER	PLATED W/ZnCr GOLD	UN-PLATED or PLATED SILVER	PLATED W/ZnCr GOLD		
1/4	8 N·m (71 lb in)	11 N·m (97 lb in)	12 N·m (106 lb in)	16 N·m (142 lb in)	8.5 N·m (75 lb in)	12.2 N·m (109 lb in)
5/16	17 N·m (150 lb in)	23 N·m (204 lb in)	24 N·m (212 lb in)	32 N·m (283 lb in)	17.5 N·m (155 lb in)	25 N·m (220 lb in)
3/8	30 N·m (22 lb ft)	40 N·m (30 lb ft)	43 N·m (31 lb ft)	57 N·m (42 lb ft)	31 N·m (23 lb ft)	44 N·m (33 lb ft)
7/16	48 N·m (36 lb ft)	65 N·m (48 lb ft)	68 N·m (50 lb ft)	91 N·m (67 lb ft)	50 N·m (37 lb ft)	71 N·m (53 lb ft)
1/2	74 N·m (54 lb ft)	98 N·m (73 lb ft)	104 N·m (77 lb ft)	139 N·m (103 lb ft)	76 N·m (56 lb ft)	108 N·m (80 lb ft)
9/16	107 N·m (79 lb ft)	142 N·m (105 lb ft)	150 N·m (111 lb ft)	201 N·m (148 lb ft)	111 N·m (82 lb ft)	156 N·m (115 lb ft)
5/8	147 N·m (108 lb ft)	196 N·m (145 lb ft)	208 N·m (153 lb ft)	277 N·m (204 lb ft)	153 N·m (113 lb ft)	215 N·m (159 lb ft)
3/4	261 N·m (193 lb ft)	348 N·m (257 lb ft)	369 N·m (272 lb ft)	491 N·m (362 lb ft)	271 N·m (200 lb ft)	383 N·m (282 lb ft)
7/8	420 N·m (310 lb ft)	561 N·m (413 lb ft)	594 N·m (438 lb ft)	791 N·m (584 lb ft)	437 N·m (323 lb ft)	617 N·m (455 lb ft)
1	630 N·m (465 lb ft)	841 N·m (620 lb ft)	890 N·m (656 lb ft)	1187 N·m (875 lb ft)	654 N·m (483 lb ft)	924 N·m (681 lb ft)

NOTE: For Imperial Units, 1/4 in and 5/16 in hardware torque specifications are shown in pound-inches. 3/8 in through 1 in hardware torque specifications are shown in pound-feet.

IDENTIFICATION

Inch Bolts and free-spinning nuts

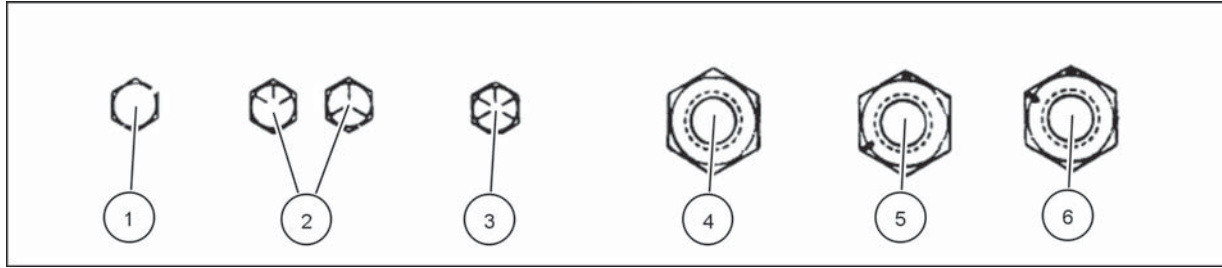

20083682 3

Grade Marking Examples

SAE Grade Identification			
1	Grade 2 - No Marks	4	Grade 2 Nut - No Marks
2	Grade 5 - Three Marks	5	Grade 5 Nut - Marks 120 ° Apart
3	Grade 8 - Five Marks	6	Grade 8 Nut - Marks 60 ° Apart

Inch Lock Nuts, All Metal (Three optional methods)

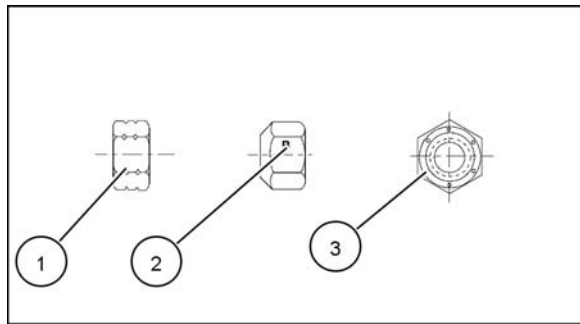

20090268 4

Grade Identification

Grade	Corner Marking Method (1)	Flats Marking Method (2)	Clock Marking Method (3)
Grade A	No Notches	No Mark	No Marks
Grade B	One Circumferential Notch	Letter B	Three Marks
Grade C	Two Circumferential Notches	Letter C	Six Marks

Thank you so much for reading.
Please click the “Buy Now!”
button below to download the
complete manual.



After you pay.

You can download the most
perfect and complete manual in
the world immediately.

Our support email:

ebooklibonline@outlook.com