

ORIGINAL INSTRUCTIONS

# OPERATOR'S MANUAL

---

**T4030N**

**T4040N**

**T4050N**

**T4060N**

Tractors

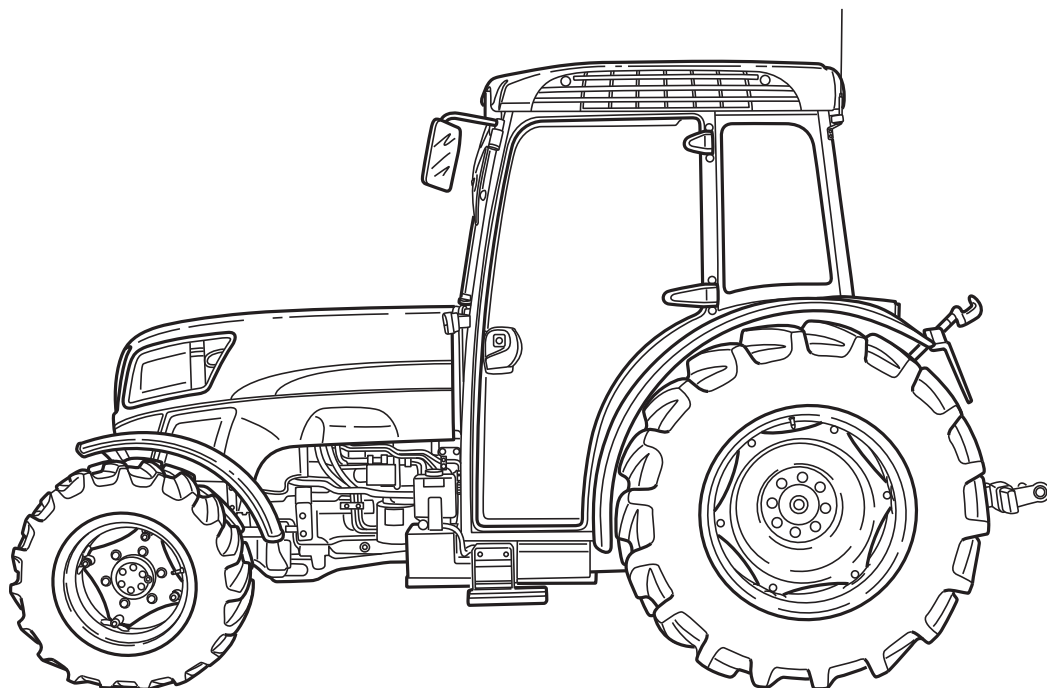

**Part Number 84515936**

2nd edition English

February 2012



# Contents

---

## 1 GENERAL INFORMATION

Note to the Owner .....	1-1
EC Declaration of Conformity .....	1-2
Noise levels.....	1-4
Electro-magnetic interference (EMC).....	1-5
International symbols .....	1-6
Introduction .....	1-8
Tractor intended use.....	1-9
Ecology and the Environment .....	1-11
Identification plates .....	1-12
Component Identification .....	1-14

## 2 SAFETY INFORMATION

Safety rules .....	2-1
Safety information .....	2-2
Air conditioning safety regulations.....	2-6
Vehicle vibration levels .....	2-7
Cab protection (ROPS and FOPS).....	2-8
Roll over protective structure (ROPS).....	2-10
Machine stability.....	2-11
Tractor jacking points.....	2-13
Fire or explosion prevention .....	2-14
Safety signs .....	2-15

## 3 CONTROLS/INSTRUMENTS

### ACCESS TO OPERATOR'S PLATFORM

Cab .....	3-1
Heating system.....	3-4
Heating, ventilation or air-conditioning control .....	3-5
Cab air filter.....	3-7

### OPERATOR'S SEAT

Operator seat.....	3-9
--------------------	-----

### FORWARD CONTROLS

Digital dashboard.....	3-11
Front controls.....	3-17

### LEFT-HAND SIDE CONTROLS

Console Left - Control identification .....	3-21
Parking brake for hydraulic transmissions.....	3-23

### RIGHT-HAND SIDE CONTROLS

Console Right - Control identification.....	3-24
---	------

---

## EXTERIOR CONTROLS

Console - Control identification .....	3-27
--	------

## DISPLAY SETTINGS

Instrument panel - Program .....	3-28
----------------------------------	------

## TRANSMISSION

TRANSMISSION - Operating 4WD models .....	3-35
Transmission with gear reducer and mechanical reversing mechanism .....	3-36
Transmission with gear reducer and electrohydraulic reversing mechanism .....	3-39
Transmission with additional gear reducer and mechanical reversing mechanism ...	3-42
Transmission with gear reducer, mechanical reversing mechanism and splitter .....	3-44
Parking brake for hydraulic transmissions.....	3-47
Transmission with gear reducer, electrohydraulic reversing mechanism and HI-LO control .....	3-48
Transmission with gear reducer, electrohydraulic reversing mechanism, HI-LO control and electrohydraulic clutch.....	3-51
Transmission with gear reducer, electrohydraulic reversing mechanism, HI-LO control and additional reducer .....	3-56

## 4 OPERATING INSTRUCTIONS

### STARTING THE UNIT

STARTING SYSTEM - Safety rules .....	4-1
STARTING SYSTEM - Care.....	4-2
STARTING SYSTEM - Start.....	4-3

### STOPPING THE UNIT

STARTING SYSTEM - Stop .....	4-5
------------------------------	-----

### MOVING THE UNIT

Moving the machine .....	4-6
--------------------------	-----

## 5 TRANSPORT OPERATIONS

### ROAD TRANSPORT

Transporting the machine .....	5-1
--------------------------------	-----

### PREPARING FOR ROAD TRANSPORT

Wheels and tires.....	5-1
Tyre dimensions .....	5-6
Wheel tread settings.....	5-8
Tire Combinations and Tread Positions .....	5-12
Ballast .....	5-15
Ballast .....	5-16

---

Maximum permitted weights.....	5-18
--------------------------------	------

## RECOVERY TRANSPORT

Towing the tractor.....	5-20
-------------------------	------

## 6 WORKING OPERATIONS

### GENERAL INFORMATION

Four-wheel drive with electrohydraulic actuation.....	6-1
Four-wheel drive with electrohydraulic actuation.....	6-2
Differential lock system.....	6-3
Differential lock system.....	6-4
Power take off (PTO).....	6-5
Hydraulic lift.....	6-9
Hydraulic lift with electronic control.....	6-12
Three-point linkage.....	6-17
Additional equipment attachment points.....	6-21
Additional equipment attachment points.....	6-22
Hydraulic control valves.....	6-23
Electrohydraulically controlled side hydraulic valves.....	6-26
Side hydraulic valves.....	6-28
Maintenance.....	6-29

## 7 MAINTENANCE

### GENERAL INFORMATION

Introduction.....	7-1
Various controls.....	7-3
Body maintenance.....	7-4
Break-in period.....	7-6
Fuel supply.....	7-7
General specification - Biodiesel Fuels.....	7-8
Fluids and lubricants.....	7-9
Opening the hood.....	7-11

### MAINTENANCE CHART

Maintenance Chart.....	7-12
------------------------	------

### AS REQUIRED

Radiator expansion tank.....	7-15
Windscreen washer tank.....	7-15
Road light - Check.....	7-15
Road light - Check.....	7-16
Clutch pedal adjustment.....	7-16
PARKING BRAKE - Adjust.....	7-16
Radiator - Cleaning.....	7-17
Tire pressure.....	7-17

---

Wheel nuts torque .....	7-17
Brake pedals .....	7-18

## AT WARNING MESSAGE DISPLAY

Engine air filters .....	7-19
Fuel filter water drain .....	7-20
Fuel filter water drain .....	7-21
Brake fluid level.....	7-21

## EVERY 10 HOURS OR EACH DAY

Engine oil level .....	7-23
------------------------	------

## EVERY 50 HOURS

Rear wheel hub.....	7-24
Lift and linkage .....	7-24
2WD steering cylinder .....	7-24
4WD steering cylinders.....	7-25
2WD front axle pivot .....	7-25
4WD front axle pivot .....	7-26
2WD left-hand stub axle.....	7-26
2WD right-hand stub axle .....	7-27
4WD propeller shaft .....	7-27
Front lift arms shaft .....	7-28
Front PTO coupling.....	7-28

## EVERY 100 HOURS

Transmission oil cooler .....	7-29
Air conditioning condenser .....	7-29
Intercooler .....	7-29
Cab air filter.....	7-30
Cab recirculated air filter .....	7-30

## EVERY 300 HOURS

Alternator belt.....	7-31
Alternator belt.....	7-31
Battery - Check .....	7-31
Transmission oil filter .....	7-32
Oil filter models with power shuttle/dual command.....	7-32
Engine air filters .....	7-32
Transmission oil level.....	7-33
4WD front axle housing.....	7-33
4WD front axle housing.....	7-33
4WD front axle housing.....	7-34
4WD front axle final drives .....	7-34
4WD front axle final drives .....	7-34
4WD front axles stub .....	7-35
4WD front axles stub .....	7-35
2WD front wheels.....	7-35

---

## EVERY 500 HOURS

Engine oil and filter .....	7-36
Fuel filter .....	7-37
Fuel pre-filter .....	7-38

## EVERY 600 HOURS

Engine oil and filter .....	7-39
Fuel filter .....	7-40
Fuel pre-filter .....	7-41

## EVERY 1200 HOURS OR ANNUALLY

Cab air filters .....	7-42
Cab recirculated air filter .....	7-42
Engine air filters .....	7-42
Fuel tank .....	7-43

## EVERY 1200 HOURS OR EVERY 2 YEARS

4WD front axle housing With brake .....	7-44
4WD front axle housing Without brake .....	7-44
4WD front axle housing .....	7-45
Engine valves .....	7-46
Change transmission oil .....	7-46
Washing cooling system .....	7-47

## EVERY 1800 HOURS

Fuel injector - Check .....	7-50
-----------------------------	------

## ELECTRICAL SYSTEM

Battery .....	7-51
Battery switch - Check .....	7-53
Fuses and relays .....	7-54
Fuses and relays location .....	7-55
Fuses and relays location .....	7-57
Fuses and relays location Fuses and relays on cab right hand upright .....	7-59
Power sockets .....	7-59
Head light - Adjust .....	7-60
Head light - Adjust .....	7-61
Head light - Replace .....	7-61
Head light - Replace .....	7-61
Brake, direction and rear lamp replacing .....	7-62
Number plate light .....	7-62
Front sidelight and marker light replacing .....	7-63
Front sidelight and marker light replacing .....	7-63
Front and rear work lights .....	7-63
Work lights for tractors with roll bar .....	7-64
Interior light .....	7-64

---

## CALIBRATIONS

Dual command calibration .....	7-65
Electronic lift calibration .....	7-68

## 8 TROUBLESHOOTING

### FAULT CODE RESOLUTION

Display fault codes .....	8-1
TRUBLESHOOTING ENGINE .....	8-3
ELECTRICAL POWER SYSTEM - Troubleshooting ELECTRICAL SYSTEM ....	8-5
PRIMARY HYDRAULIC POWER SYSTEM - Troubleshooting HYDRAULIC SYSTEM .....	8-6
HITCH - Troubleshooting HYDRAULIC LIFT AND 3-POINT LINKAGE .....	8-7
SERVICE BRAKE - Troubleshooting .....	8-8
ENVIRONMENT CONTROL - Troubleshooting .....	8-9

### ALARM(S)

Alarms .....	8-10
Alarms, cause, solutions .....	8-12

## 9 SPECIFICATIONS

Technical data .....	9-1
----------------------	-----

## 10 ACCESSORIES

Radio - Operating .....	10-1
Hydraulic valve for trailer brakes Not available on all markets .....	10-6
Towing equipment .....	10-8
Quick coupling three point linkage .....	10-12
FRONT PTO - Operating .....	10-14
Front hydraulic lift .....	10-17
Quick coupling three point linkage .....	10-18

---

# 1 - GENERAL INFORMATION

## Note to the Owner

This manual contains information concerning the adjustment and maintenance of your new equipment. You have purchased a dependable machine, but only by proper care and operation can you expect to receive the performance and long service built into this equipment. Please have all operators read this manual carefully and keep it available for ready reference.

Your NEW HOLLAND AGRICULTURE dealer will instruct you in the general operation of your new equipment. Your dealer's staff of factory-trained service technicians will be glad to answer any questions that may arise regarding the operation of your machine.

Your NEW HOLLAND AGRICULTURE dealer carries a complete line of genuine NEW HOLLAND AGRICULTURE service parts. These parts are manufactured and carefully inspected to insure high quality and accurate fitting of any necessary replacement parts. Be prepared to give your dealer the model and product identification number of your new equipment when ordering parts. Locate these numbers now and record them below. Refer to the 'General Information' section of this manual for the location of the model and product identification numbers of your machine.

PLEASE RECORD THE FOLLOWING INFORMATION
Model:
Product Identification Number (PIN):



This is the safety alert symbol. It is used with and without signal words to alert you to potential personal injury hazards. Obey all safety messages that follow this symbol to avoid possible death or injury.

### **▲ WARNING**

**Illustrations in this manual may show protective shielding open or removed to better illustrate a particular feature or adjustment.  
Replace all shields before operating the machine.  
Failure to comply could result in death or serious injury.**

W0012A

### Engine tampering statement:

**ATTENTION:** *The fuel system and engine on your machine are designed and built to government emissions standards. Tampering by dealers, customers, operators and users is strictly prohibited by law. Failure to comply could result in government fines, rework charges, invalid warranty, legal action and possible confiscation of the machine until rework to original condition is completed. Engine service and/or repairs must be done by a certified technician only!*





For your better and easier understanding of the document you'll find original text reproduced hereafter together with some notes

Clause of 2006/42/EC Annex II	EN EC Declaration of conformity According to Directive 2006/42/EC.
1.A.1	We, <b>[1]</b>
1.A.2	Represented by Giuseppe Gavioli, CNH Europe Holding S.A. 13, Rue Aldringen L-1118 Luxembourg
1.A.3	declare under our sole responsibility, that the product: Agricultural tractor Trade Name: <b>[2]</b> Model: <b>[3]</b> Type: <b>[4]</b> Serial Number: <b>[5]</b>
1.A.4	to which this declaration relates, fulfils all the relevant provisions of the Directive 2006/42/EC, amended by <b>[6]</b> .
1.A.7	For the relevant implementation of the provisions of the Directive, the following (harmonised) standards have been applied: • ISO 26322-1 part 1 or 2 Other standards: see Operators Manual
1.A.9	Place and date of the declaration: <b>[7]</b>
1.A.10	Name and signature of the authorised person: <b>[8]</b>

## HEALTH AND SAFETY RELATED STANDARDS APPLIED TO YOUR TRACTOR

- FOPS level on your tractor cab is certified according to OECD Code 10.
- BLUE CAB is certified Category 2 according to EN 15695-1.
- HVAC (Heating, ventilation Air Conditioning ) CAB is certified Category 1 according to EN 15695-1.
- HV (Heating, ventilation) cab is certified Category 1 according to EN 15695-1.
- NOISE EMISSION LEVELS are rated according to 77/311/EEC.
- VIBRATION LEVELS are rated according to 78/764/EEC.
- ROPS PROTECTION is certified according to EN 15694.

**NOTE:** See safety section 1 in this manual for further explanation and details on above mentioned standards and specific terminology.

## Noise levels

In conformity with the EU directive, the levels of noise at the operator's ear with the tractor stationary are measured in conformity with Directive **2009/76/EC**.

### NOISE LEVEL MEASURABLE AT OPERATOR'S EAR, dB (A)

<b>TRACTORS WITH ROLL BARS</b>	
Model	Noise level
<b>T4030N T4040N</b>	<b>84 dB</b>
<b>T4050N T4060N</b>	<b>86 dB</b>

<b>TRACTORS WITH CABS</b>		
Model	Tractors with closed cab - doors shut	
	Rear window closed	Rear window open
	Noise level	
<b>T4030N T4040N</b>	<b>78 dB</b>	<b>79 dB</b>
<b>T4050N T4060N</b>	<b>81 dB</b>	<b>82 dB</b>

## Electro-magnetic interference (EMC)

This machine complies strictly with the European Regulations on electro-magnetic emissions. However, interference may arise as a result of add-on equipment which may not necessarily meet the required standards. As such interference can result in serious malfunction of the unit and/or create unsafe situations, you must observe the following:

- Ensure that each piece of non- NEW HOLLAND AGRICULTURE equipment fitted to the machine bears the CE mark.
- The maximum power of emission equipment (radio, telephones, etc.) must not exceed the limits imposed by the national authorities of the country where you use the machine.
- The electro-magnetic field generated by the add-on system should not exceed **24 V/m** at any time and at any location in the proximity of electronic components.

Failure to comply with these rules will render the NEW HOLLAND AGRICULTURE warranty null and void.

## International symbols

TYPICAL APPLICATIONS	RECOMMENDED SI (METRIC) UNITS		IMPERIAL UNIT	
	NAME	SYMBOL	NAME	SYMBOL
<b>AREA</b>				
	hectare	<b>ha</b>	acre	<b>ha</b>
	square meter	<b>m<sup>2</sup></b>	square foot	<b>ft<sup>2</sup></b>
			square inch	<b>in<sup>2</sup></b>
	square millimetre	<b>mm<sup>2</sup></b>	square inch	<b>in<sup>2</sup></b>
<b>ELECTRICITY</b>				
	ampere	<b>A</b>	ampere	<b>A</b>
	volt	<b>V</b>	volt	<b>V</b>
	microfarad	<b>μF</b>	microfarad	<b>μF</b>
	ohm	<b>Ω</b>	ohm	<b>Ω</b>
<b>FORCE</b>				
	kilonewton	<b>kN</b>	pound	<b>lb</b>
	newton	<b>N</b>	pound	<b>lb</b>
<b>FORCE PER LENGTH</b>				
	Newton metres	<b>N/m</b>	pound per inch	<b>lb/in</b>
<b>FREQUENCY</b>				
	megahertz	<b>MHz</b>	megahertz	<b>MHz</b>
	kilohertz	<b>kHz</b>	kilohertz	<b>kHz</b>
	hertz	<b>Hz</b>	hertz	<b>Hz</b>
<b>FREQUENCY - ROTATIONAL</b>				
	revolution per minute	<b>r/min</b>	revolution per minute	<b>r/min<sup>a</sup></b>
		<b>rpm</b>		<b>rpm</b>
<b>LENGTH</b>				
	kilometre	<b>km</b>	mile	<b>mi</b>
	meter	<b>m</b>	foot	<b>ft</b>
	centimetre	<b>cm</b>	inch	<b>in</b>
	millimetre	<b>mm</b>	inch	<b>in</b>
	micrometer	<b>μm</b>		
<b>MASS</b>				
	kilogram	<b>kg</b>	pound	<b>lb</b>
	gram	<b>g</b>	ounce	<b>oz</b>
	milligram	<b>mg</b>		
<b>POWER</b>				
	kilowatt	<b>kW</b>	horsepower	<b>Hp</b>
	watt	<b>W</b>	Btu/hour	<b>Btu/hr</b>
			Btu/minute	<b>Btu/min</b>
<b>PRESSURE or STRESS (FORCE PER AREA)</b>				
	kilopascal	<b>kPa</b>	pound per square inch	<b>psi</b>
			inch of mercury	<b>inHg</b>
	pascal	<b>Pa</b>	inch of water	<b>inH<sub>2</sub>O</b>
	megapascal	<b>MPa</b>	pound per square inch	<b>psi</b>

Thank you so much for reading.  
Please click the “Buy Now!”  
button below to download the  
complete manual.



After you pay.

You can download the most  
perfect and complete manual in  
the world immediately.

Our support email:

[ebooklibonline@outlook.com](mailto:ebooklibonline@outlook.com)