

OPERATOR'S MANUAL

T8.275

T8.300

T8.330

T8.360

T8.390

Tractor

from PIN ZBRC07000 and after

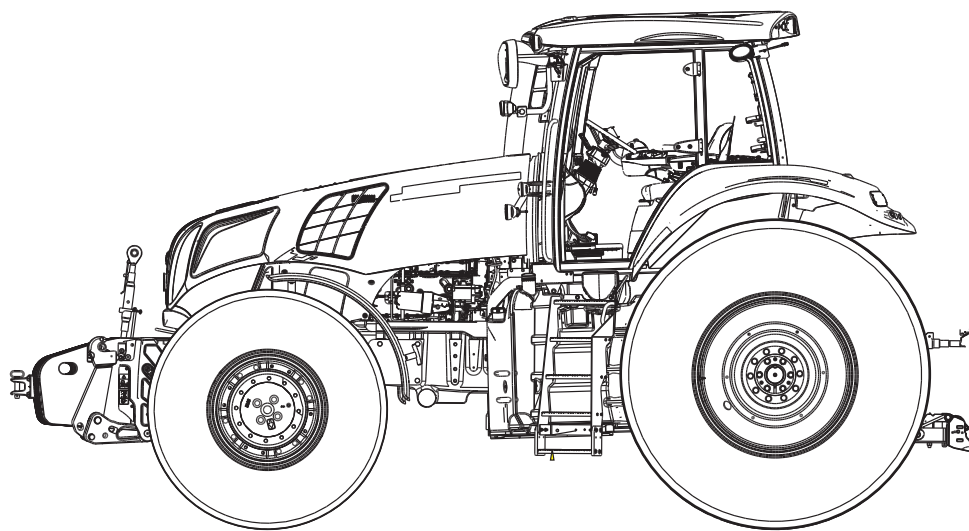

Part number 84516821

1st edition English
September 2011



Contents

1 GENERAL INFORMATION

Your tractor	1-1
Emissions warranty	1-2
Note to the Owner	1-4
Manual storage	1-4
Product identification	1-5
Machine orientation	1-7
Component location	1-8

2 SAFETY INFORMATION

Safety rules and signal word definitions	2-1
Read the Operators Manual	2-2
Proposition 65	2-2
Safety rules - General	2-2
Safety rules - Air conditioning system	2-3
Safety rules - Basic operating	2-3
Safety rules - Battery	2-4
Safety rules - Driving on public roads	2-4
Safety rules - Electrical storm safety	2-5
Safety rules - Fire prevention	2-5
Safety rules - General maintenance	2-5
Safety rules - Hazardous chemicals	2-7
Safety rules - Implements, tools and trailers	2-7
Safety rules - Instructional seat	2-8
Safety rules - Mounting and dismounting	2-8
Safety rules - Operator presence system	2-8
Safety rules - PTO operation	2-9
Safety rules - Roll over and tip over	2-9
Safety rules - Utility power lines	2-10
Safety rules - Vehicle vibration	2-10
Safety rules - Wheels and tires	2-10
Roll over protective structure (ROPS)	2-12
Safety decals	2-13
Selective catalytic reduction (SCR) decal	2-23
Ecology and the environment	2-24

3 CONTROLS/INSTRUMENTS

ACCESS TO OPERATOR'S PLATFORM

Tractor access	3-1
----------------------	-----

OPERATOR'S SEAT

Overview	3-2
Control identification	3-3

INSTRUCTOR'S SEAT

Overview	3-6
----------------	-----

FORWARD CONTROLS

Steering column	3-7
Front console	3-10
Pedal controls	3-12

LEFT-HAND SIDE CONTROLS

Pneumatic trailer brake	3-14
-------------------------------	------

RIGHT-HAND SIDE CONTROLS

Armrest console	3-15
Multi function handle	3-16
Hand throttle lever	3-19
Control panel	3-20
Remote valve controls	3-28
Joystick	3-29
Rear hitch controls	3-31
Armrest compartment	3-33
Adjusting the armrest console	3-35

REARWARD CONTROLS

Fender console	3-36
Automatic temperature controls	3-39
Automatic temperature control system	3-42
Ventilation	3-43

OVERHEAD CONTROLS

Interior lamps	3-45
----------------------	------

EXTERIOR CONTROLS

Rear fender controls	3-46
Front hitch	3-47

INSTRUMENT CLUSTER

Overview	3-48
Gauges	3-48
Status and warning icons	3-50
Upper display	3-53
Lower display	3-55
Keypad	3-57
Setup menu	3-59
Rear tire radius chart	3-65
Adjust menu	3-66
Performance instrumentation	3-73

4 OPERATING INSTRUCTIONS

COMMISSIONING THE UNIT

Before starting the engine	4-1
----------------------------------	-----

STARTING THE UNIT

Normal engine starting	4-4
Cold starting aids	4-7
Cold temperature operation	4-9
Cold temperature operation	4-11

STOPPING THE UNIT

Stopping the engine	4-13
---------------------------	------

MOVING THE UNIT

Powershift transmission	4-14
Best practices for prolonged transmission life	4-15
Inching pedal and throttle	4-16
Transmission controls	4-17
Upper display	4-20
Driving the vehicle	4-22
Setting default gears	4-27
Ground speed management (GSM)	4-29
Selective catalytic reduction (SCR) system	4-36
SCR inducement strategy - 2011	4-37
SCR inducement strategy - 2012	4-41
Mechanical front drive (MFD)	4-44
Differential lock system	4-48
Suspended axle	4-51
Ride control	4-59
Constant engine speed	4-61
Headland management system	4-63

5 TRANSPORT OPERATIONS

ROAD TRANSPORT

Tractor warning lamps and SMV symbol	5-1
Wide transport marker light	5-2
Tractor warning lamps	5-4
Safe transport speed	5-5
Implement warning lamps and SMV symbol	5-6
Safety chain	5-7

SHIPPING TRANSPORT

Securing the tractor for shipping	5-8
---	-----

RECOVERY TRANSPORT

Safety rules.....	5-9
Towing the tractor.....	5-10

6 WORKING OPERATIONS

GENERAL INFORMATION

Product overview.....	6-1
-----------------------	-----

REAR PTO

Safety rules.....	6-2
Connecting the PTO.....	6-5
Interchangeable PTO shaft.....	6-6
Reversible PTO shaft.....	6-12
Rear PTO operation.....	6-14
PTO fender switch operation.....	6-18
Auto PTO operation.....	6-19

FRONT PTO

Overview.....	6-22
Front PTO operation.....	6-23

REAR HITCH

Identification.....	6-26
Link adjustment.....	6-27
Hitch high clearance adjustment.....	6-31
Hydraulic links.....	6-34
Sway limiter adjustment.....	6-36
Lower link block adjustment.....	6-37
Mechanical float adjustment.....	6-38
Hitch quick coupler - Category III/IIIN.....	6-39
Hitch quick coupler - Category IVN.....	6-44
Hitch operation.....	6-48
Hitch remote switch operation.....	6-53
Position control operation.....	6-54
Load control operation.....	6-56
Slip control operation.....	6-58
Hitch set point.....	6-60

FRONT HITCH

Overview.....	6-62
Front hitch operation.....	6-62

DRAWBARS AND TOWING ATTACHMENTS

Rear towing - Safety rules.....	6-70
Drawbar capacity/position.....	6-71

Adjusting the drawbar	6-75
-----------------------------	------

AUXILIARY POWER CONNECTIONS

Cab power connections	6-77
-----------------------------	------

HYDRAULIC REMOTE CONTROL VALVES

Valve couplers and connections	6-79
Motor return circuit	6-82
Power beyond circuit	6-83
Flow capacity	6-83
Hydraulic transport lock	6-85
Operating the controls	6-86
Remote valve display screens	6-90
Remote hydraulic auto mode	6-94
Auto depth control	6-96
Joystick operation	6-98

BALLASTING THE TRACTOR

Guidelines	6-102
Tire load and inflation charts	6-107
Weights, cast metal and liquid	6-119
Wheel slip and power hop performance	6-131

MECHANICAL FRONT DRIVE (MFD) AXLES

Tire combinations and tread positions	6-134
Steering and oscillation stops	6-141
Tread and fender settings - standard MFD axles	6-144
Tread and fender settings - heavy duty MFD axles	6-149
Tread and fender settings - heavy duty class 5 MFD axles	6-161
Tread and fender settings - heavy duty class 5 suspended MFD axles	6-174
Tread and fender settings - scissors suspension MFD axles	6-186

REAR AXLE

Rear wheel installation	6-198
Rear wheel tread settings	6-201

7 MAINTENANCE

GENERAL INFORMATION

Safety rules	7-1
Opening the hood	7-2
Closing the hood	7-4
Filling the fuel tank	7-5
Filling the DEF/AdBlue® tank	7-6
Battery disconnect switch	7-7
Battery access and service	7-8

Tire and rim service	7-10
Tractor jacking points	7-12
Capacities	7-14
Consumables - Engine oil	7-16
Consumables - Diesel fuel	7-18
Consumables - Biodiesel fuels	7-19
Consumables - Diesel exhaust fluid (DEF)/AdBlue®	7-21
Consumables - Coolant solutions	7-23
Electrical component location	7-24
Lamps and bulbs	7-29
Maintenance chart notes	7-30

MAINTENANCE CHART

Maintenance Chart	7-31
-------------------------	------

At warning message display

Air filter service icon/message	7-33
Fuel filter water separator	7-34
Transmission oil filter switch	7-35
Hydraulic oil filter switch	7-38

First 10 to 50 hours

Differential and planetary oil	7-41
Wheel bolt torque	7-41
Weight bolt torque	7-41

Every 10 hours or daily

Engine oil level	7-42
Transmission oil level	7-43
Engine coolant level	7-44
Engine auxiliary fuel filter	7-45
Air reservoir	7-46
Rear hitch and front axle	7-47

Every 50 hours or weekly

Engine fuel pre-filter	7-48
------------------------------	------

Every 100 hours

Front hitch	7-49
Front PTO drive shaft	7-51

Every 300 hours

Battery water level (Note E)	7-52
Engine air intake hoses	7-54
Engine coolant level - deaeration tank	7-56
Wheel bolt torque	7-57
Weight bolt torque	7-57

Front axle (Note A)	7-58
Rear hitch (Note A)	7-67
Fuel tank.....	7-69
Differential and planetary oil level (Note B).....	7-70
Transmission oil pressure	7-72
Front PTO oil level.....	7-73

Every 400 hours

Cab air filter.....	7-74
---------------------	------

Every 600 hours

Engine oil and filter	7-77
Engine coolant antifreeze protection	7-79
Engine coolant hoses and clamps.....	7-79
Engine primary fuel filter.....	7-82
Engine fuel pre-filter	7-85
Fuel system bleeding.....	7-88
Changeable PTO internal splines	7-90
DEF/AdBlue® in-line filter	7-91
Front PTO oil and filter	7-93

Every 1000 hours or annually

Pneumatic brake system dryer	7-94
------------------------------------	------

Every 1200 hours or annually

Differential and planetary oil.....	7-94
Engine air filters	7-99
Engine air precleaner.....	7-103

Every 1500 hours

Transmission oil	7-105
Transmission oil filter	7-107
Regulated transmission filter	7-108
Engine crankcase filter	7-109

Every 1800 hours

DEF/AdBlue® supply module filter	7-113
--	-------

Every 2000 hours

Engine coolant.....	7-114
Engine valve adjustment (Note C).....	7-116

Every 3000 hours

Engine vibration damper (Note C).....	7-117
Emergency steering system.....	7-118

Every 5000 hours

Fuel injector nozzles (Note C)	7-119
--------------------------------------	-------

As required

Vehicle fire prevention	7-120
Engine primary air filter	7-121
Grille screen and radiator area	7-124
Fuel tank vent filter	7-126
Transmission clutch and accumulator	7-126
Tire pressure	7-126
Fan belt	7-127
Cab suspension, if equipped	7-130
Remote valve collection bottle	7-131
Engine auxiliary fuel filter	7-132
Cab fabric and carpet	7-134
Seat belt	7-134

STORAGE

Tractor storage	7-135
Removal from storage	7-136

ELECTRICAL SYSTEM

Radio or audio system	7-137
Battery removal and installation	7-138
Auxiliary battery connections	7-140
Head light - Replace	7-141
Grille work light	7-145
Fender tail light and warning light	7-147
Roof warning light	7-149
Roof work light	7-151
Belt line, roof or fender work light	7-153
High intensity work light	7-155
Wide transport marker light	7-157
Rotating beacon light	7-158
Interior light - Replace	7-159

8 TROUBLESHOOTING

ALARM(S)

Display warnings overview	8-1
Display warnings - Level 1	8-2
Display warnings - Level 2	8-5
Display warnings - Level 3	8-8
Display warnings - Level 4	8-10

SYMPTOM(S)

Engine symptoms	8-12
Transmission symptoms.....	8-14
Hydraulic symptoms	8-15
Hitch symptoms	8-16
Brake symptoms.....	8-17
Cab environment symptoms.....	8-18
Electrical power system symptoms.....	8-19

9 SPECIFICATIONS

Engine specifications	9-1
Power train specifications	9-2
Operating speeds.....	9-5
Vehicle dimensions and shipping weight	9-13
Maximum operating weight.....	9-16

10 ACCESSORIES

Front wheel fenders - Dynamic fenders	10-1
Farming system displays	10-8
Chemical tank mounting.....	10-9
Loader connection and operation	10-11
Trailer brake connections.....	10-12
General accessories.....	10-14

11 FORMS AND DECLARATIONS

Delivery report - owner copy	11-1
Delivery report - dealer copy	11-2
First service - owner copy	11-4
First service - dealer copy	11-6

1 - GENERAL INFORMATION

Your tractor

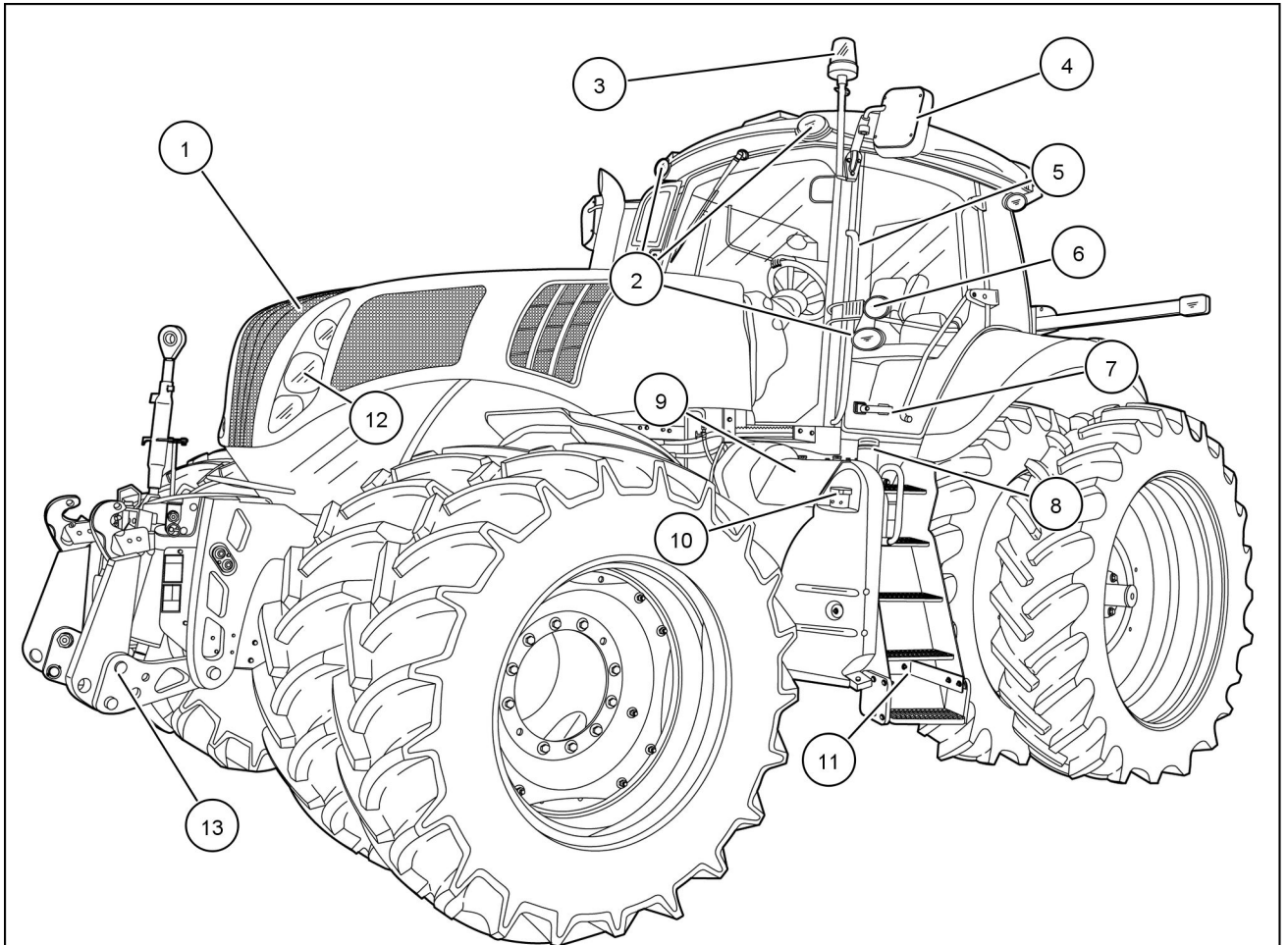

RCPH11CCH027GAA 1

Emissions warranty

U.S. EPA and California Emissions Control Warranty Statement

NEW HOLLAND AGRICULTURE warrants to the ultimate purchaser and each subsequent purchaser that the engine is designed, built and equipped so as to conform with U.S. Environmental Protection Agency regulations applicable at the time of manufacture and that it is free from defects in workmanship or material which would cause it not to meet these regulations for a period of:

- 2 years or 1,500 hours of operation, whichever occurs first, for engines less than 19kW/25HP
- 5 years or 3,000 hours of operation, whichever occurs first, for engines greater than or equal to 19kW/25HP

NOTE: *This warranty applies to all units operated in the United States or Canada.*

Coverage

The model year, class of diesel engine, and emission application determination for your engine are identified on the Emission Control Information Label. This label is affixed to one of the following areas of the engine: the top of engine's rocker arm cover, the right-hand side of the oil pan, and the right-hand side of the engine front gear cover. The warranty period begins on the date the new equipment is sold to the first retail purchaser. The presence of the emission control label is the indication that the engine conforms to the applicable standards. Any emission control system parts which are proven defective during normal use will be repaired or replaced during the warranty period.

The engine owner has responsibility to perform all the required maintenance listed in the Owner's Manual. NEW HOLLAND AGRICULTURE will not deny an emission warranty claim solely because no record of maintenance exists; however, a claim may be denied if failure to perform maintenance resulted in the failure of a warranted part.

It is recommended that replacement parts used for maintenance or repairs be NEW HOLLAND AGRICULTURE Service Parts to maintain the quality originally designed into your emission certified engine. The use of non- NEW HOLLAND AGRICULTURE parts does not invalidate the warranty on other components unless the use of such parts causes damage to warranted parts.

The manufacturer is liable for damages to other engine components caused by the failure of any warranted emission control system part. NEW HOLLAND AGRICULTURE is not responsible for failures resulting from improper repair or the use of parts that are not genuine NEW HOLLAND AGRICULTURE or NEW HOLLAND AGRICULTURE approved parts.

Component coverage

New engines certified for sale and registered will have the following items covered by the emission warranty, depending on the emission level of the engine, if the items were first installed on the new engine as original equipment:

Fuel injection system

- Fuel injection pump
- Fuel injectors
- Fuel injection lines

Air induction system

- Intake manifold
- Turbocharger system (includes exhaust manifold)
- Charge air cooler

Positive crankcase ventilation system (if applicable)

- PVC valve
- Oil fill cap

Exhaust after treatment Devices (if applicable)

- Catalytic converter (DOC)
- Diesel particulate filter (DPF)
- Selective catalytic reduction (SCR)
- Diesel Exhaust Fluid (DEF) tank and dispensing systems

Exhaust Gas Recirculation Systems (EGR)

- EGR valve assembly
- EGR cooler

Cold Start Enrichment Systems

Electronic Control Units, Sensors, Solenoids, and Wiring harnesses used in above systems

Emissions warranty does not cover

- Repairs arising from storage deterioration, failure to maintain the equipment, negligence, alteration, improper use of the equipment, collision or other accident, vandalism, or other casualty, or operation beyond rated capacity or specification.
- Repairs arising from abuse or neglect, including but not limited to: operation without adequate coolant or lubricants, adjustments to the fuel system outside equipment specifications, over-speeding, improper storage, starting, warm-up, or shutdown practices, incorrect fuel or contaminated fuel, oil or other fluids.
- Normal maintenance services, such as engine tune-ups, engine fuel system cleaning, checks, adjustments, shimming, etc.
- Items replaced due to customer demand.
- Labor charges performed by anyone except a dealer authorized by contract to repair the equipment, unless they qualify under special provisions (i.e. outside labor).
- Any and all travel costs for items such as towing, service calls, or transporting a unit to and from the place where the warranty service is performed.
- Normal maintenance costs, including but not limited to: lubricants, coolants, fluids, fuel, filters, and associated labor. Lubricants, filters, and coolants may qualify for warranty reimbursement if they require replacement as a DIRECT RESULT of a defect in material or workmanship.
- Claims involving the inspection or reconditioning of units after storage or prior use.
- Repairs arising from service performed by agents not approved by NEW HOLLAND AGRICULTURE.
- Repairs arising from any unauthorized modification to the product or the use of non- NEW HOLLAND AGRICULTURE parts, implements or attachments.
- Removal, replacement, or installation of non- NEW HOLLAND AGRICULTURE optional equipment, attachments or components.
- Premiums charged for overtime labor costs or out of shop expenses.
- Economic loss including lost profits, crop loss, equipment rental, or other expense.
- Unauthorized modification or updating machines without a warrantable failure.
- Any and all costs of dealer shop supplies incurred with repairs, including but not limited to: solvents, cleaners, anti-seize lubricants, loctite, sealant, adhesive, oil-dry, shop towels, etc.
- Failure of the machine, its implements or attachments caused by improper field application or loading.
- Any and all costs for coolant, fuel, or lube (oil) analysis including supplies and lab recommendations.
- Cost associated with cleaning of machine in preparation for servicing.

Note to the Owner

This manual contains important information about the safe operation, adjustment and routine maintenance of your T8. series tractor. The manual is divided into eleven chapters as outlined in the table of contents. Refer to the index at the end of this manual for locating specific items about your tractor.

Do NOT operate or permit anyone to operate or service this machine until you or the other persons have read this manual. Use only trained operators who have demonstrated the ability to operate and service this machine correctly and safely.

This Operator's Manual is to be stored in the manual compartment behind the operator's seat in the vehicle. Make

sure this manual is in good condition. Contact your dealer to obtain additional manuals.

Your NEW HOLLAND AGRICULTURE dealer will instruct you in the general operation of your new equipment. Your dealer's staff of factory-trained service technicians will be glad to answer any questions that may arise regarding the operation of your machine. They will also provide any after-sales service you may need, and genuine NEW HOLLAND AGRICULTURE parts, your guarantee of quality and match.

New Holland Top Service is also available. Call 1-866-NEWHLND (1-866-639-4563) or email na.topservice@cnh.com.

Manual storage

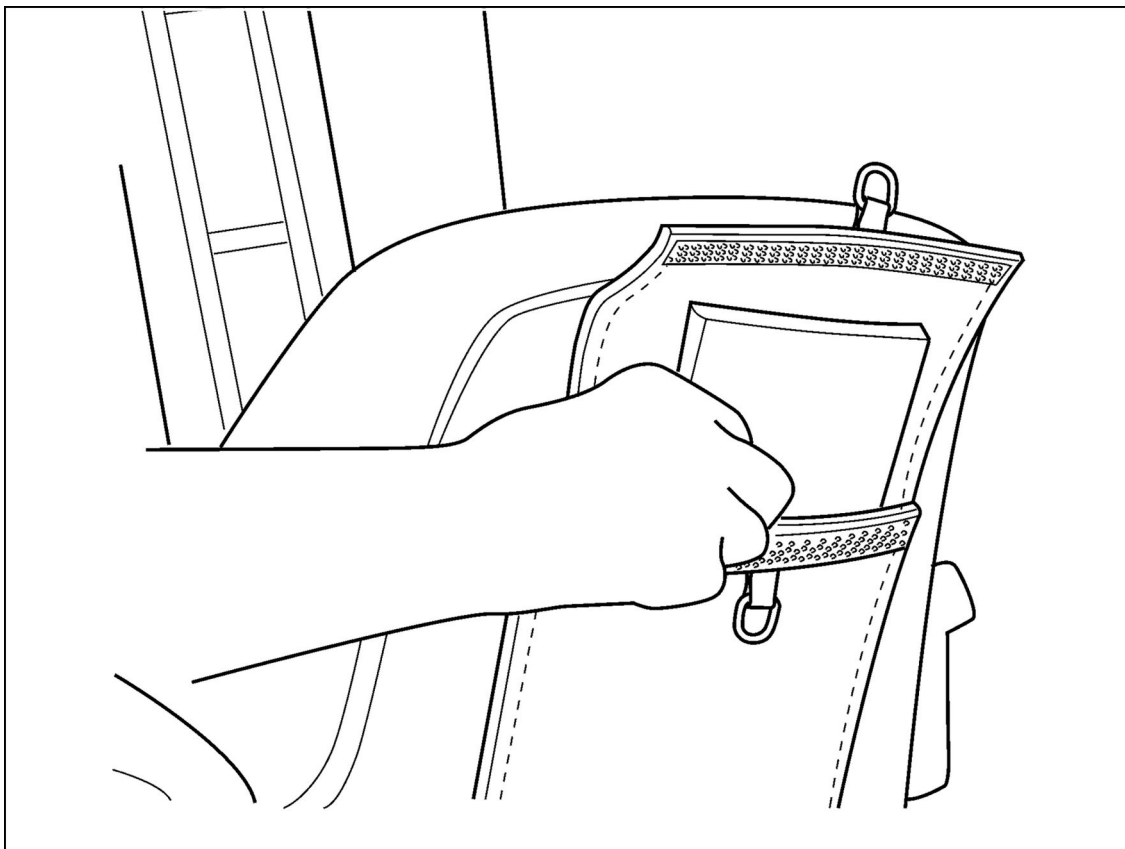

RCPH08CCH001FAB 1

Keep the Operator's Manual in the storage compartment provided on your tractor. The Operator's Manual must be available for use by all operators.

Thank you so much for reading.
Please click the “Buy Now!”
button below to download the
complete manual.



After you pay.

You can download the most
perfect and complete manual in
the world immediately.

Our support email:

ebooklibonline@outlook.com