

NEW HOLLAND
TN70F
TN80F
TN95F

86729781 8/02
603.64.551.10

OPERATOR'S MANUAL

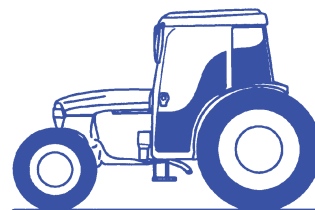

NEW HOLLAND

CONTENTS

Section - Page

Section 1

General information and safety measures	1-1
Tractor identification plates	1-2
Important ecological considerations	1-5
Always work safely	1-6
Working safely	1-7
Safety Decals	1-13
Symbols	1-17
Tractor noise level information sheet	1-18

Section 2

Controls, instruments and operation	2-1
Before using the tractor	2-1
Control panel with digital instrument	2-2
Operation indicator light panel	2-3
Electronic module	2-7
Lights cluster	2-12
Operation controls	2-13
Electro-hydraulically controlled differential lock	2-14
Seat	2-17
Steering wheel adjustment	2-18
Cab with heating and ventilation	2-19
Transmission with range gear and mechanical shuttle version (16F+16R)	2-30
Transmission with hydraulic HI-LO /Power Shuttle version (32F+16R)	2-34

Section 3

Field operation	3-1
Starting and stopping	3-2
Brakes	3-6
Transmission clutch pedal	3-7
Electronically controlled electro-hydraulic 4WD	3-8
Differential lock	3-10
Electro-hydraulically controlled differential lock	3-11
Power take-off	3-13
Mechanically controlled hydraulic lift	3-17
Three-point linkage	3-21
Rear remote control valves	3-24
Track adjustment	3-26
Steering angle adjustment	3-29
Tyres	3-32

Tyre combinations	3-38
Tyre pressures for 4WD models	3-39
Ballasting	3-42
Maximum permitted weights	3-43
Steering wheel adjustment	3-45

Section 4

Lubrication and maintenance	4-1
Tractor refuelling	4-2
Access for inspection and maintenance	4-4
Lubrication and maintenance table	4-5
Flexible maintenance	4-7
Instrument panel warning lights	4-10
Every 10 hours of work	4-12
Every 50 hours of work	4-15
Every 300 hours of work	4-18
Every 900 hours of work	4-23
Every 1200 hours or every year	4-25
Every 1200 hours or every 2 years	4-25
General maintenance	4-29
Electrical system	4-31
Recommendations for bodywork maintenance	4-43
Refuelling and topping up	4-44

Section 5

Troubleshooting, causes and solutions	5-1
---	-----

Section 6

Prolonged tractor inactivity	6-1
------------------------------------	-----

Section 7

Accessories	7-1
Towing equipment	7-2
Lateral remote control valves	7-4

Section 8

Specifications and data	8-1
-------------------------------	-----

Section 9

Inspections and/or operations to be carried out	9-1
---	-----

Section 10

Alphabetical index	10-1
--------------------------	------

FEDERAL EMISSIONS WARRANTY

(California owner's emissions warranty is covered elsewhere)

New Holland warrants that your new 1996 and later heavy-duty off-road diesel engine was designed, built, and equipped to conform to applicable U.S. Environmental Protection Agency regulations for a period of use of five years or 3,000 hours of operation, whichever occurs first.

The new model year, class of diesel engine, and emission application determination for your engine are identified on the emission control information label affixed to the top of your engine's rocker arm cover. The warranty period begins on the date the new equipment is sold to the first retail purchaser.

Any emission control system parts which are proven defective during normal use will be repaired or replaced during the warranty period. The warranty repairs and service will be performed by any authorized New Holland dealer at the dealer's place of business, with no charge for parts or labor (including diagnosis).

As the engine owner, you are responsible to perform all the required maintenance listed in your owner's manual. New Holland will not deny an emission warranty claim solely because you have no record of maintenance; however, a claim may be denied if your failure to perform maintenance resulted in the failure of a warranted part. Receipts covering regular maintenance should be retained in the event of questions and these receipts should be passed on to each subsequent owner of the engine.

It is recommended replacement parts used for maintenance or repairs be New Holland Service Parts to maintain the quality originally designed into your emission certified engine. The use of non-New Holland parts does not invalidate the warranty on other components unless the use of such parts causes damage to warranted parts.

New Holland wishes to assure the emission control systems warranty is being properly administered. If you believe you have not received the service entitled to under this warranty, you should contact the nearest New Holland Branch Office for assistance.

Service Department
New Holland North America, Inc.
500 Diller Avenue
New Holland, PA 17557
(717) 355-1121

Please note that the Emission Warranty does not cover:

1. Systems and parts that were not first installed on the new equipment or engine as original equipment by New Holland.
2. Part malfunctions caused by abuse, misuse, improper adjustment, modification, alteration, tampering, disconnection, improper or inadequate maintenance, or use of non-recommended fuels and lubricating oils.
3. Accident caused damage, acts of nature, or other events beyond New Holland's control.
4. Replacement of expendable items made in connection with scheduled maintenance.
5. Parts requiring replacement, inspection or adjustment maintenance intervals for reasons other than being defective.
6. Parts which are not New Holland Service Parts.
7. Loss of time, inconvenience, loss of use of equipment/engine or commercial loss.
8. Equipment with altered or disconnected hourmeter where the hours cannot be determined.
9. Equipment normally operated outside the United States.
10. Non-defective parts replaced by other than New Holland dealers.

Coverage

This emission control system warranty applies to the following emission control parts.

Fuel Injection Pump
Fuel Injectors
Turbocharger
Intake Manifold
Exhaust Manifold
Boost Pressure Tubing-connection to Aneroid Device ON F.I.P.

CALIFORNIA EMISSION CONTROL WARRANTY STATEMENT

Your Warranty Rights and Obligations

The California Air Resources Board and New Holland are pleased to explain the emission control system warranty on your engine. In California, new 1997 and later heavy-duty off-road engines from 100 to 150 HP must be designed, built, and equipped to meet the State's stringent anti-smog standards. New Holland must warrant the emission control system on your engine for the periods of time listed below, provided there has been no abuse, neglect, or improper maintenance of your engine.

Your emission control system includes parts such as the fuel injection system and the air induction system.

Where a warrantable condition exists, New Holland will repair your heavy-duty off-road engine at no cost to you, including diagnosis, parts, and labor.

Manufacturer's Warranty Coverage:

The 1997 and later heavy-duty off-road engines are warranted from the original date of delivery for five years or 3,000 hours of operation, whichever occurs first. If any emission-related part on your engine is defective, the part will be repaired or replaced by New Holland.

Owner's Warranty Responsibilities:

- As the heavy-duty off-road engine owner, you are responsible for the performance of the required maintenance listed in your owner's manual. New Holland recommends that you retain all receipts covering maintenance on your heavy-duty off-road engine, but New Holland cannot deny warranty solely for the lack of receipts or for your failure to ensure the performance of all scheduled maintenance.
- As the heavy-duty off-road engine owner, you should, however, be aware that New Holland may deny you warranty coverage if your heavy-duty off-road engine or a part has failed due to abuse, neglect, improper maintenance, or unapproved modifications.
- Your engine is designed to operate on commercially available diesel fuel only. Use of any other fuel may result in your engine no longer operating in compliance with California's emissions requirements.
- You are responsible for initiating the warranty process. The ARB suggests that you present your heavy-duty off-road engine to a New Holland dealer as soon as a problem exists. The warranty repairs should be completed by the dealer as expeditiously as possible.

If you have questions regarding your warranty rights and responsibilities, you should contact your Branch Office at the address and phone number listed on the Owner Assistance page of your equipment's operator manual.

- Prior to the expiration of the warranty, you must give notice of any failure of an emission control warranted part. Such notice must be given to New Holland or an authorized dealer, and you must deliver the engine to the repair location.
- You, the owner, are responsible for incidental costs incurred by yourself or your employees as a result of a warrantable failure. Examples of such costs are communication expenses, meals and lodging.
- The owner is responsible for any business costs or losses, any "downtime" expenses and any "cargo" damage which result from the failure of a warranted part. New Holland is not responsible for other incidental or consequential damages, including but not limited to fines, theft, vandalism or collisions.

Parts covered:

This emission control system warranty applies to the following emission control parts.

Fuel Injection Pump
Fuel Injectors
Turbocharger
Intake Manifold
Exhaust Manifold
Boost Pressure Tubing-connection to Aneroid Device ON F.I.P.

Any replacement part, equivalent in performance and durability, may be used in the performance of any maintenance or repairs and must be provided without charge to the owner. The use of these parts does not reduce the warranty obligations of New Holland. However, New Holland recommends the use of new, genuine New Holland service parts or New Holland approved rebuilt parts and assemblies. New Holland also recommends that the engine be serviced by a New Holland authorized dealer.

New Holland Responsibilities

Warranty work will be provided at no charge to the owner at any authorized dealer, using new genuine New Holland service parts or New Holland approved rebuilt parts or assemblies..

The owner will not be charged for diagnostic labor which leads to the determination that a warranted part is defective, if the diagnostic work was performed at a warranty station.

New Holland is liable for damages to other engine components caused by the failure under warranty of any warranted part.

Warranty Limitations

New Holland is not responsible for failures resulting from abuse or neglect by owner or operator.

New Holland warrants to the ultimate purchaser and each subsequent purchaser that the engine is designed, built, and equipped so as to conform with all applicable regulations adopted by the Air Resources Board, and that it is free from defects in materials and workmanship which cause the failure of a warranted part.

Any warranted part which is not scheduled for replacement as required maintenance, or which is scheduled only for regular inspection to the effect of "repair or replace as necessary" is warranted for the warranty period.

Any warranted part which is scheduled for replacement as required maintenance is warranted for the period of time prior to the first scheduled replacement point for that part.

New Holland is liable for damages to other engine components caused by the failure under warranty of any warranted part.

CALIFORNIA

Proposition 65 Warning

Diesel engine exhaust and some of its constituents are known to the State of California to cause cancer, birth defects, and other reproductive harm.

Battery posts, terminals and related accessories contain lead and lead compounds, chemicals known to the State of California to cause cancer and birth defects or other reproductive harm. Wash hands after handling.

SECTION 1

GENERAL INFORMATION AND SAFETY MEASURES

GENERAL NOTE

This Use and Maintenance Manual provides a guide for the user with regard to running-in, use and maintenance of the tractor.

Read this manual carefully and keep in a convenient place for future reference. Do not hesitate to contact your local dealer for any queries concerning your tractor. The dealer can provide skilled personnel, trained by the manufacturer, original service parts and all tools and equipment necessary for your service requirements.

The tractor is designed as a power generator and drive-propulsion unit for use in normal and traditional agricultural conditions.

The tractor is also designed to provide maximum performance, economic running and easy use over a wide range of operations. Prior to delivery, all machines are carefully inspected (by both the Manufacturer and your local authorised dealer), to make sure that they reach the user in perfect condition. To maintain the tractor in this condition and ensure trouble-free operation, the routine maintenance described in Section 3 of this manual must be carried out at the specified intervals.

CLEANING THE TRACTOR

Your tractor is an advanced machine, fitted with an electro-hydraulic control system. Care must be taken when cleaning the tractor, especially if a pressurised water cleaner is used.

- Never stand too close to the tractor or direct the water jet on electrical components, seals or intake openings, etc.
- Never direct jets of cold water at the hot engine or exhaust. See also Section 3 (Recommendations for bodywork maintenance).

SAFETY MEASURES

Safety precautions for the operator and bystanders are shown on page vii to xiii inclusive. Read the safety instructions and follow recommendations and hints **before** starting to use the tractor.

SERVICE AFTER THE FIRST 50 HOURS OF WORK

The operations required for the first service are shown at the end of the Manual, immediately prior to the index.

After the first 50 hours of use, return to the dealer with your tractor and this Manual in order to carry out the Manufacturer's checks and to fill in the certificates included on pages 9-1 and 9-3). The first sheet (page 9-1) must be compiled on completion of the service and held by the dealer. The second sheet (page 9-3) must be kept in the Manual for documentation and reference purposes. **Check that both copies are signed by both yourself and the dealer.**

SPARE PARTS

"Non-original" spare parts have not been tested or authorised by the Manufacturer. Instalment and/or use of such products may adversely affect the tractor's design specifications, thereby compromising operational safety. The manufacturer cannot be held responsible for any damage resulting from the use of "non-original" spare parts. No modifications may be made to the tractor without written authorisation from the Manufacturer.

WARRANTY

The tractor is guaranteed in accordance with current legislation in your country and in line with contractual agreements reached with the dealer at the time of sale. However, the warranty is no longer valid if the rules and instructions for the use and maintenance of the tractor, described in this Manual, are not observed.

TRACTOR IDENTIFICATION PLATES

Serial numbers identify the tractor and its main components. The identification data must be supplied by the dealer for requests for spare parts or service operations. Identification data is of fundamental importance in the event of theft of the tractor. The location of the various identification data is shown below.

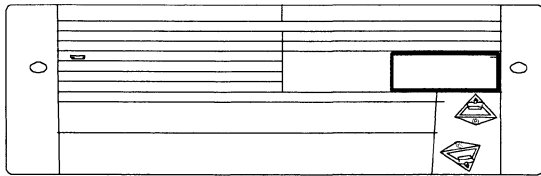

Frame identification data plate.

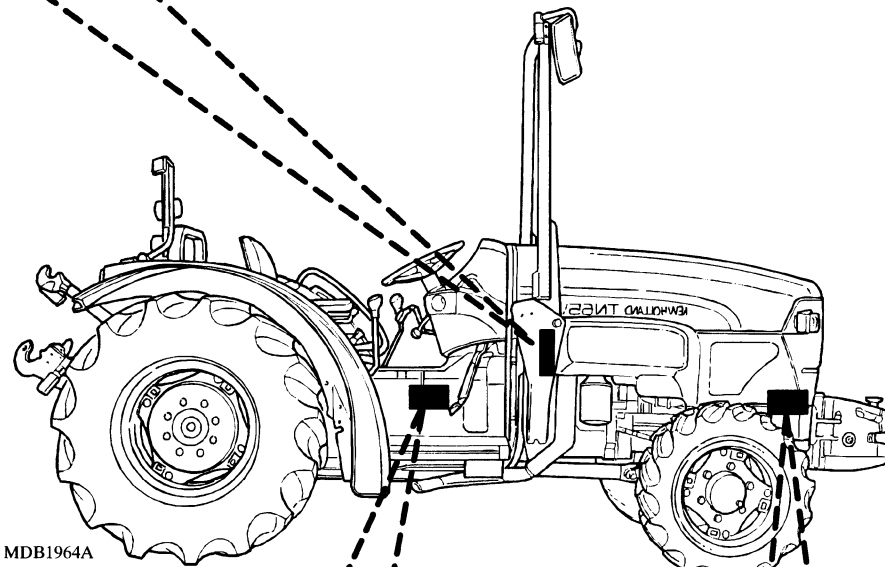

Frame and engine type identification data plate.

NEW HOLLAND ITALIA S.p.A.	
TIPO	
OMOLOGAZIONE	
TELAIO	
MASSA TOTALE AMMISSIBILE (kg)	
CARICO AMMISSIBILE SULL'ASSE ANTERIORE (kg)	DA: A:
CARICO AMMISSIBILE SULL'ASSE POSTERIORE (kg)	DA: A:
CARICO RIMORCHIABILE AMMISSIBILE	
MASSA RIMORCHIABILE NON FRENATA (kg)	
MASSA RIMORCHIABILE CON FRENATURA INDIPENDENTE (kg)	
MASSA RIMORCHIABILE CON FRENATURA AD INERZIA (kg)	
MASSA RIMORCHIABILE CON FRENATURA ASSISTITA (kg)	
NEW HOLLAND ITALIA S.p.A. MODENA ITALY MADE IN ITALY	COEFFICIENTE ASSORBIMENTO <input type="checkbox"/>

Tractor frame number identification data plate (stamped on the axle support under the bonnet).

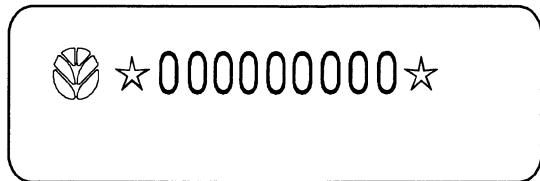

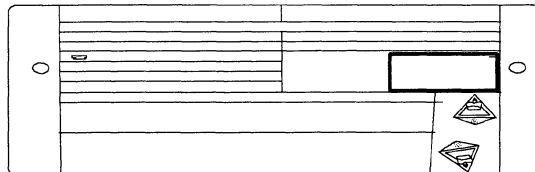

Cab identification data plate (on rear RH side).

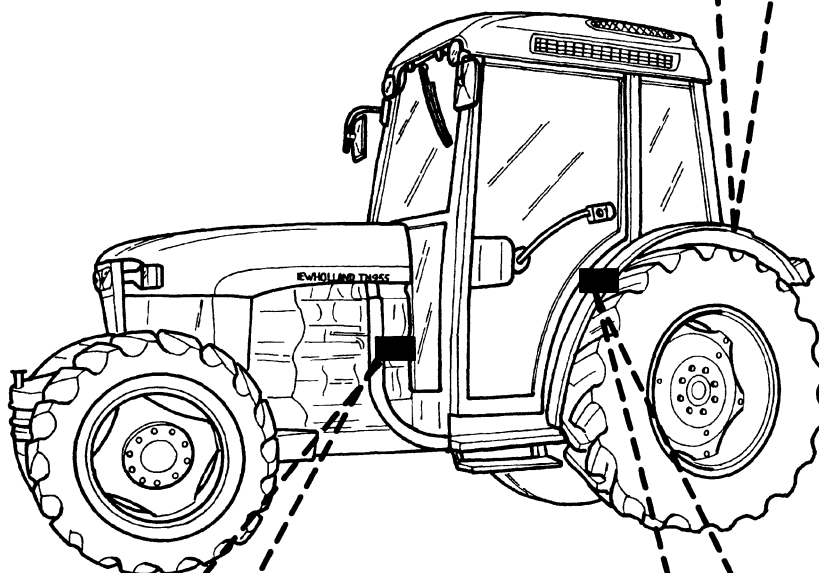

MDD2463A

Frame and engine type identification data plate (inside the cab).

Engine identification data plate (on engine body).

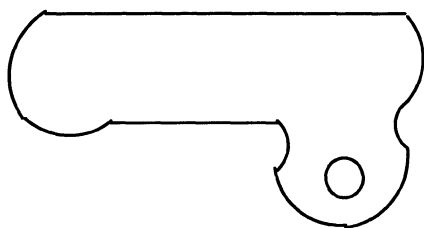

NEW HOLLAND ITALIA S.p.A.	
TIPO	
OMLOGAZIONE	
TELAJO	
MASSA TOTALE AMMISSIBILE (kg)	
CARICO AMMISSIBILE SULL'ASSE ANTERIORE (kg)	DA: A:
CARICO AMMISSIBILE SULL'ASSE POSTERIORE (kg)	DA: A:
CARICO RIMORCHIABILE AMMISSIBILE	
MASSA RIMORCHIABILE NON FRENATA (kg)	
MASSA RIMORCHIABILE CON FRENATURA INDIPENDENTE (kg)	
MASSA RIMORCHIABILE CON FRENATURA AD INERZIA (kg)	
MASSA RIMORCHIABILE CON FRENATURA ASSISTITA (kg)	
NEW HOLLAND ITALIA S.p.A. MODENA ITALY MADE IN ITALY	COEFFICIENTE ASSORBIMENTO

INTRODUCTION AND SAFETY MEASURES



Frame number identification plate (stamped on the axle support).

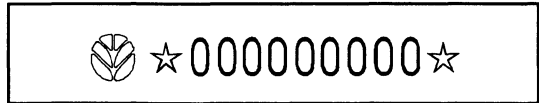
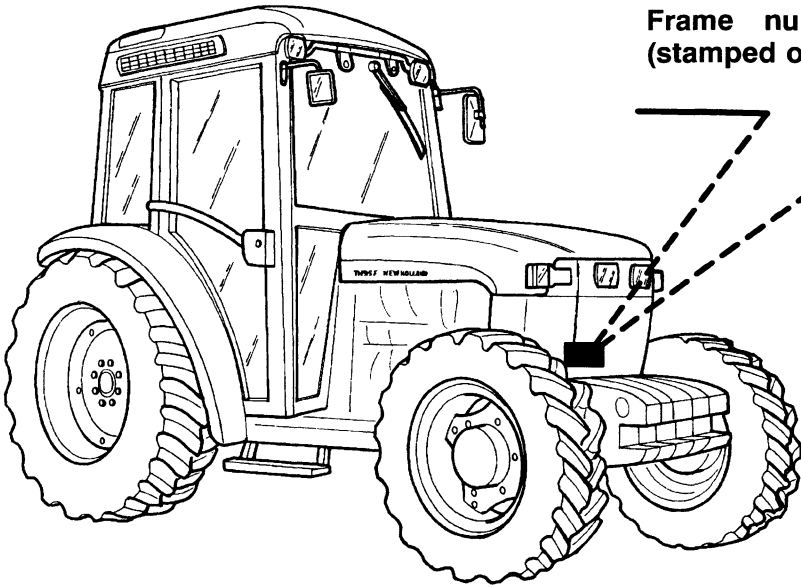

Axle identification plates (RH side near stub axles).

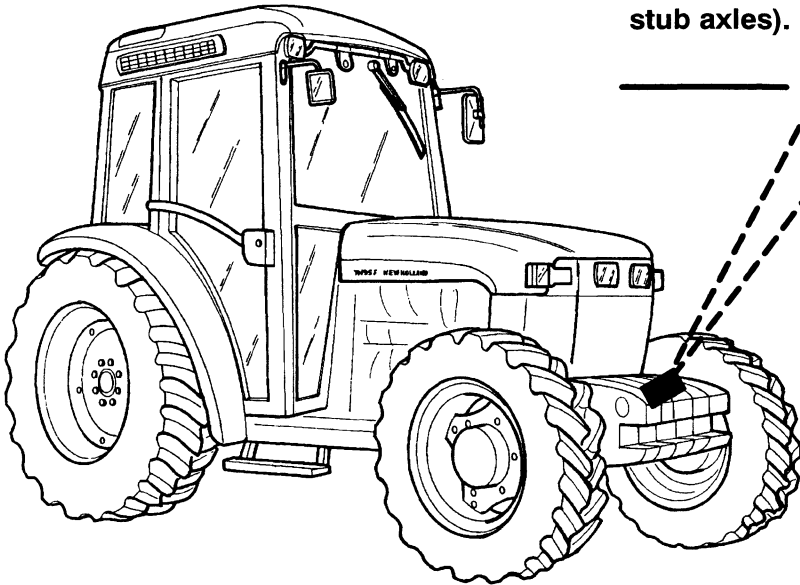

MDD2464A

MDD2464A

IMPORTANT ECOLOGICAL CONSIDERATIONS

Soil, air and water are essential elements for agriculture and for life in general. If local legislation does not control the treatment of certain substances, the production of which is necessitated by advanced technologies, products derived from chemical and petrochemical products must be used and disposed of according to the rules of common sense.

The following recommendations may be of help:

- Find out what the relevant legislation in your country stipulates.
- Ask your suppliers of lubricants, oils, fuels, anti-freeze, detergents, etc. for information on the effects of these products on humans and the environment and for instructions concerning their use, storage and disposal. In many cases, local agricultural consultants will be able to provide assistance.

SUGGESTIONS

1. Avoid using unsuitable, pressurised filling systems or fuel cans when filling tanks, as these may cause considerable spillage and leakage of liquids.
2. As a general rule, do not allow liquid fuels, lubricants, acids, solvents, etc., to come into contact with the skin. The majority of these products contain substances that are potential health hazards.
3. Modern lubricants contain additives. Do not burn contaminated fuel oils and/or oils used in conventional heating systems.

4. Avoid spillage when transferring used engine cooling liquids, engine and transmission lubricants, hydraulic oils, brake fluids, etc. Never mix used brake oil with fuel oil, or fuel oil with lubricants. Store safely until suitable disposal can be arranged according to national legislation or local regulations.
5. Modern anti-freeze liquids and solutions, e.g.: anti-freeze and other additives, must be replaced every two years. They must not be left to be absorbed into the ground, but must be collected and disposed of in a suitable manner.
6. Do not open the air conditioning systems to carry out work. These systems contain gas that must not be released into the atmosphere. Contact your dealer or specialised personnel, who are equipped with the appropriate equipment and are authorised to re-fill the system.
7. Any leakage or defect in the engine cooling or hydraulic systems must be repaired immediately.
8. Do not increase the pressure in pressurised systems, as this may cause component parts to burst.
9. When welding, make sure that hoses are properly protected as sparks or molten material may puncture or weaken the tubes and sleeves, resulting in leakage of oil, cooling liquid, etc.
10. Do not adjust the setting of the fuel delivery system as this will alter the emission of exhaust fumes.

NOTE: THE ENGINES INSTALLED ON THE TRACTORS COMPLY WITH ANTI-POLLUTION LEGISLATION.

ALWAYS WORK SAFELY



This warning symbol points out important messages concerning your safety.

Read the following safety regulations carefully and follow the recommendations in order to avoid potential hazards and safeguard your health and safety.

In this manual the symbol is accompanied by the following key-words:

—————  **CAUTION**  —————

When the warning is to prevent potential damage to the machine, which could also put the operator's safety at risk.

—————  **DANGER**  —————

This warning specifically indicates a potential danger to the user or to any other person directly involved.

Failure to observe the instructions preceded by the aforementioned key words (**CAUTION** and **DANGER**) may result in severe or fatal injury to the persons involved.

Furthermore, this manual also contains instructions in italics preceded by the terms **NOTE** and **WARNING**, with the following relevance in relation to machine protection:

NOTE: Underlines the correct procedure or technique to be followed by the operator.

—————  **CAUTION**  —————

Informs the operator of the danger of damaging the machine if the specified procedure is not followed.

IMPORTANT WARNINGS

The machine is designed and produced exclusively for agricultural use.

All other use will be considered to be contrary to the use specified by NEW HOLLAND, who cannot be held liable for damage to property or the machine, or for personal injuries which may result.

Persons who risk improper use will therefore assume the responsibility for any consequences arising from such use.

Compliance with the instructions for use, maintenance and repairs described in this manual, are the essential preconditions for the use specified by NEW HOLLAND.

The machine must only be used, serviced or repaired by personnel trained in the relevant working methods and safety regulations and who have been authorised to work on the machine.

The user must also observe the rules concerning general safety and accident prevention, including the Highway Code when driving on public highways.

Any arbitrary modifications made to this machine will release NEW HOLLAND from any liability resulting from damage or injury.

NEW HOLLAND and all distribution organisations, inclusive of, but not restricted to, national, regional or local distributors, cannot be held liable for damage resulting from the malfunction of parts and/or components not approved by NEW HOLLAND.

Under no circumstances will a guarantee be issued for products made or sold by NEW HOLLAND that are damaged as a result of the malfunction of parts and/or components not approved by NEW HOLLAND.

WORKING SAFELY

1. During the manufacturing of this tractor, every step has been taken to ensure safe operation. However, the best way to avoid accidents is to exercise caution at all times. Once the accident has already happened it is too late to remember what steps should have been taken.
2. Read this manual carefully before starting, using, carrying out maintenance, refuelling or performing any other type of operation on the tractor.
3. The time spent reading this manual will allow you to get to know your tractor, thereby saving time and effort. This will also help prevent accidents from taking place.
4. Read all the safety decals on the machine and follow the instructions thereon before starting, operating, refuelling or carrying out maintenance on the machine. Promptly replace any decals that are damaged, lost or illegible. Clean the decals if they are covered by mud or debris.
5. Remember that the tractor is exclusively designed for agricultural use. Any other use will require prior authorisation from NEW HOLLAND.
6. It is advisable to keep a first aid kit on hand.
7. The tractor must only be used by responsible personnel, trained in tractor use and authorised to operate the machine.
8. Do not alter the injection system calibration in an attempt to increase maximum engine speed.
9. Do not wear loose clothing that may be trapped in moving parts. Check that all rotating parts connected to the power take-off are correctly protected.
10. Do not alter the calibration of the pressure relief valves in the various hydraulic circuits (hydrostatic steering, hydraulic lift, auxiliary distributors, etc.).
11. Avoid using the tractor in unsuitable physical conditions, stop work instead.
12. Enter and leave the tractor using the steps and handles provided. Keep these fittings free of mud and debris.
13. Always operate with the cab or roll bar correctly and securely fitted on the tractor: periodically check that the fittings are not loose and that all parts of the structure are free from any damage and deformation. Do not modify the roll bar by welding parts, drilling holes, etc., as this could adversely affect the rigidity of the structure.

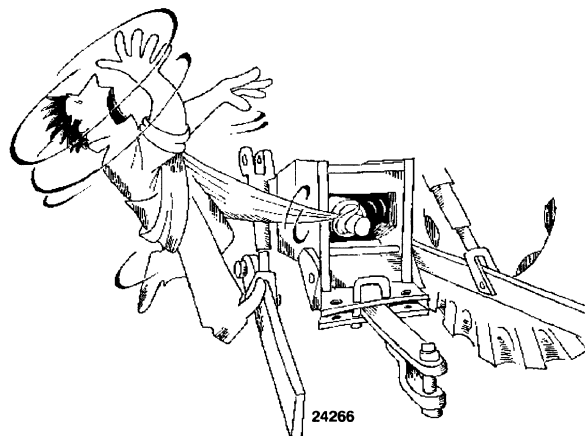

Thank you so much for reading.
Please click the “Buy Now!”
button below to download the
complete manual.



After you pay.

You can download the most
perfect and complete manual in
the world immediately.

Our support email:

ebooklibonline@outlook.com