

NEW HOLLAND

TB100

TB110

TB120

87039953 10/03
82987580

OPERATOR'S MANUAL

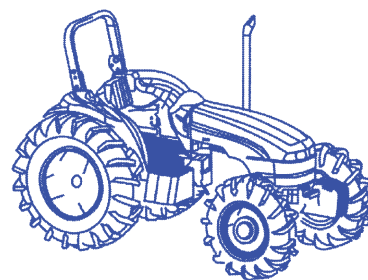

NEW HOLLAND

TO THE OWNER

This manual contains information concerning the adjustment and maintenance of your New Holland Model TB100, TB110 and TB120 tractor. You have purchased a dependable machine, but only by proper care and operation can you expect to receive the performance and long service built into this mower-conditioner. Please have all operators read this manual carefully and keep it available for ready reference.

Your New Holland dealer will instruct you in the general operation of your tractor. (Refer to the "Delivery Report" at the back of this manual.) Your dealer's staff of factory-trained service technicians will be glad to answer any questions that may arise regarding the operation of your tractor.



Your New Holland dealer carries a complete line of genuine New Holland service parts. These parts are manufactured and carefully inspected to insure high quality and accurate fitting of any necessary replacement parts. Be prepared to give your dealer the model and serial number of the tractor, when ordering parts. Locate these numbers now and record them below. Refer to page 0-10 of this manual for the location of the model and serial numbers of your tractor.

Model _____

Serial Number _____

 **CAUTION** 

This safety alert symbol indicates important safety messages in this manual. When you see this symbol, carefully read the message that follows and be alert to the possibility of personal injury or death.

 **CAUTION** 

Pictures in this manual may show protective shielding open or removed to better illustrate a particular feature or adjustment.
Be certain, however, to close or replace all shielding before operating the machine.

IMPROVEMENTS

New Holland North America, Inc. is continually striving to improve its products. We reserve the right to make improvements or changes when it becomes practical and possible to do so, without incurring any obligation to make changes or additions to the equipment sold previously.

CONTENTS

SAFETY	0-7
CONTROL, INSTRUMENTS AND OPERATION	1-1
LUBRICATION AND MAINTENANCE	2-1
SPECIFICATIONS	3-1
INDEX	3-21
PRE-DELIVERY SERVICE	3-23

FEDERAL EMISSIONS WARRANTY

(North America Only)

(California owner's emissions warranty is covered elsewhere)

New Holland warrants that your new 1996 and later heavy-duty off-road diesel engine was designed, built, and equipped to conform to applicable U.S. Environmental Protection Agency regulations for a period of use of five years or 3,000 hours of operation, whichever occurs first.

The new model year, class of diesel engine, and emission application determination for your engine are identified on the emission control information label affixed to the top of your engine's rocker arm cover. The warranty period begins on the date the new equipment is sold to the first retail purchaser.

Any emission control system parts which are proven defective during normal use will be repaired or replaced during the warranty period. The warranty repairs and service will be performed by any authorized New Holland dealer at the dealer's place of business, with no charge for parts or labor (including diagnosis).

As the engine owner, you are responsible to perform all the required maintenance listed in your owner's manual. New Holland will not deny an emission warranty claim solely because you have no record of maintenance; however, a claim may be denied if your failure to perform maintenance resulted in the failure of a warranted part. Receipts covering regular maintenance should be retained in the event of questions and these receipts should be passed on to each subsequent owner of the engine.

It is recommended replacement parts used for maintenance or repairs be New Holland Service Parts to maintain the quality originally designed into your emission certified engine. The use of non-New Holland parts does not invalidate the warranty on other components unless the use of such parts causes damage to warranted parts.

New Holland wishes to assure the emission control systems warranty is being properly administered. If you believe you have not received the service entitled to under this warranty, you should contact the nearest New Holland Branch Office for assistance.

Service Department
New Holland North America, Inc.
500 Diller Avenue
New Holland, PA 17557
(717) 355-1121

Please note that the Emission Warranty does not cover:

1. Systems and parts that were not first installed on the new equipment or engine as original equipment by New Holland.
2. Part malfunctions caused by abuse, misuse, improper adjustment, modification, alteration, tampering, disconnection, improper or inadequate maintenance, or use of non-recommended fuels and lubricating oils.
3. Accident caused damage, acts of nature, or other events beyond New Holland's control.
4. Replacement of expendable items made in connection with scheduled maintenance.
5. Parts requiring replacement, inspection or adjustment maintenance intervals for reasons other than being defective.
6. Parts which are not New Holland Service Parts.
7. Loss of time, inconvenience, loss of use of equipment/engine or commercial loss.
8. Equipment with altered or disconnected hourmeter where the hours cannot be determined.
9. Equipment normally operated outside the United States.
10. Non-defective parts replaced by other than New Holland dealers.

Coverage

This emission control system warranty applies to the following emission control parts.

Fuel Injection Pump
Fuel Injectors
Turbocharger
Intake Manifold
Exhaust Manifold
Boost Pressure Tubing-connection to Aneroid Device ON F.I.P.

CALIFORNIA EMISSION CONTROL WARRANTY STATEMENT

(North America Only)

(California Only)

Your Warranty Rights and Obligations

The California Air Resources Board and New Holland are pleased to explain the emission control system warranty on your engine. In California, new 1997 and later heavy-duty off-road engines from 100 to 150 HP must be designed, built, and equipped to meet the State's stringent anti-smog standards. New Holland must warrant the emission control system on your engine for the periods of time listed below, provided there has been no abuse, neglect, or improper maintenance of your engine.

Your emission control system includes parts such as the fuel injection system and the air induction system.

Where a warrantable condition exists, New Holland will repair your heavy-duty off-road engine at no cost to you, including diagnosis, parts, and labor.

Manufacturer's Warranty Coverage:

The 1997 and later heavy-duty off-road engines are warranted from the original date of delivery for five years or 3,000 hours of operation, whichever occurs first. If any emission-related part on your engine is defective, the part will be repaired or replaced by New Holland.

Owner's Warranty Responsibilities:

- As the heavy-duty off-road engine owner, you are responsible for the performance of the required maintenance listed in your owner's manual. New Holland recommends that you retain all receipts covering maintenance on your heavy-duty off-road engine, but New Holland cannot deny warranty solely for the lack of receipts or for your failure to ensure the performance of all scheduled maintenance.
- As the heavy-duty off-road engine owner, you should, however, be aware that New Holland may deny you warranty coverage if your heavy-duty off-road engine or a part has failed due to abuse, neglect, improper maintenance, or unapproved modifications.
- Your engine is designed to operate on commercially available diesel fuel only. Use of any other fuel may result in your engine no longer operating in compliance with California's emissions requirements.
- You are responsible for initiating the warranty process. The ARB suggests that you present your heavy-duty off-road engine to a New Holland dealer as soon as a problem exists. The warranty repairs should be completed by the dealer as expeditiously as possible.

If you have questions regarding your warranty rights and responsibilities, you should contact your Branch Office at the address and phone number listed on the Owner Assistance page of your equipments operator manual.

- Prior to the expiration of the warranty, you must give notice of any failure of an emission control warranted part. Such notice must be given to New Holland or an authorized dealer, and you must deliver the engine to the repair location.
- You, the owner, are responsible for incidental costs incurred by yourself or your employees as a result of a warrantable failure. Examples of such costs are communication expenses, meals and lodging.
- The owner is responsible for any business costs or losses, any "downtime" expenses and any "cargo" damage which result from the failure of a warranted part. New Holland is not responsible for other incidental or consequential damages, including but not limited to fines, theft, vandalism or collisions.

Parts covered:

This emission control system warranty applies to the following emission control parts.

Fuel Injection Pump
Fuel Injectors
Turbocharger
Intake Manifold
Exhaust Manifold
Boost Pressure Tubing-connection to Aneroid Device ON F.I.P.

Any replacement part, equivalent in performance and durability, may be used in the performance of any maintenance or repairs and must be provided without charge to the owner. The use of these parts does not reduce the warranty obligations of New Holland. However, New Holland recommends the use of new, genuine New Holland service parts or New Holland approved rebuilt parts and assemblies. New Holland also recommends that the engine be serviced by a New Holland authorized dealer.

New Holland Responsibilities

Warranty work will be provided at no charge to the owner at any authorized dealer, using new genuine New Holland service parts or New Holland approved rebuilt parts or assemblies..

The owner will not be charged for diagnostic labor which leads to the determination that a warranted part is defective, if the diagnostic work was performed at a warranty station.

New Holland is liable for damages to other engine components caused by the failure under warranty of any warranted part.

Warranty Limitations

New Holland is not responsible for failures resulting from abuse or neglect by owner or operator.

New Holland warrants to the ultimate purchaser and each subsequent purchaser that the engine is designed, built, and equipped so as to conform with all applicable regulations adopted by the Air Resources Board, and that it is free from defects in materials and workmanship which cause the failure of a warranted part.

Any warranted part which is not scheduled for replacement as required maintenance, or which is scheduled only for regular inspection to the effect of "repair or replace as necessary" is warranted for the warranty period.

Any warranted part which is scheduled for replacement as required maintenance is warranted for the period of time prior to the first scheduled replacement point for that part.

New Holland is liable for damages to other engine components caused by the failure under warranty of any warranted part.

CALIFORNIA

Proposition 65 Warning

Diesel engine exhaust and some of its constituents are known to the State of California to cause cancer, birth defects, and other reproductive harm.

Battery posts, terminals and related accessories contain lead and lead compounds, chemicals known to the State of California to cause cancer and birth defects or other reproductive harm. Wash hands after handling.

PRECAUTIONARY STATEMENTS

PERSONAL SAFETY

Throughout this manual and on machine decals, you will find precautionary statements (“**DANGER**”, “**WARNING**”, and “**CAUTION**”) followed by specific instructions. These precautions are intended for the personal safety of you and those working with you. Please take the time to read them.

DANGER

This word “**DANGER**” indicates an immediate hazardous situation that, if not avoided, will result in death or serious injury. The color associated with Danger is RED.

WARNING

This word “**WARNING**” indicates a potentially hazardous situation that, if not avoided, could result in death or serious injury. The color associated with Warning is ORANGE.

CAUTION

This word “**CAUTION**” indicates a potentially hazardous situation that, if not avoided, may result in minor or moderate injury. It may also be used to alert against unsafe practices. The color associated with Caution is YELLOW.

FAILURE TO FOLLOW THE “DANGER”, “WARNING”, AND “CAUTION” INSTRUCTIONS MAY RESULT IN SERIOUS BODILY INJURY OR DEATH.

MACHINE SAFETY

The precautionary statement (“**IMPORTANT**”) is followed by specific instructions. This statement is intended for machine safety.

IMPORTANT: *The word “IMPORTANT” is used to inform the reader of something he needs to know to prevent minor machine damage if a certain procedure is not followed.*

INFORMATION

NOTE: *Instructions used to identify and present supplementary information.*

SAFETY

PRECAUTIONARY STATEMENTS

A careful operator is the best operator. Most accidents can be avoided by observing certain precautions. To help prevent accidents, read the following precautions before operating this equipment. Equipment should be operated only by those who are responsible and instructed to do so.

Carefully review the procedures given in this manual with all operators. It is important that all operators be familiar with and follow safety precautions.

THE TRACTOR

1. Read the Operator's Manual carefully before using the tractor. Lack of operating knowledge can lead to accidents.
2. Only allow properly trained and qualified persons to operate the tractor.
3. To prevent falls, use the handrails and step plates when getting on and off the tractor. Keep steps and platform clear of mud and debris.
4. Do not permit anyone but the operator to ride on the tractor unless a passenger seat is fitted. There is no safe place for extra riders otherwise.
5. Replace all missing, illegible or damaged safety decals.
6. Keep safety decals free of dirt or grime.
7. Do not modify or alter or permit anyone else to modify or alter the tractor or any of its components or any tractor function without first consulting your dealer.
8. Tractor wheels are very heavy. Handle with care and ensure, when stored, that they cannot fall.
5. Use extreme caution and avoid hard application of the tractor brakes when towing heavy loads at road speeds.
6. Any towed vehicle whose total weight exceeds that of the towing tractor must be equipped with brakes for safe operation.
7. Never apply the differential lock when turning. When engaged, the differential lock will prevent the tractor from turning.
8. Always check overhead clearance, specifically when transporting the tractor. Watch where you are going, especially at low overhanging obstacles.
9. Use extreme caution when operating on steep slopes.
10. To avoid overturns, drive the tractor with care and at speeds compatible with safety, especially when operating over rough ground, when crossing ditches or slopes and when turning overturning.
11. If the tractor becomes stuck or the tires are frozen to the ground, reverse the tractor out to prevent corners.

DRIVING THE TRACTOR

1. Always sit in the drivers seat while starting or driving the tractor.
2. When driving on public roads, have consideration for other road users. Pull in to the side of the road occasionally to allow any following traffic to pass. Do not exceed the legal speed limit set in your area.
3. Use low beam lights when meeting a vehicle at night. Make sure the lights are adjusted to prevent blinding the drive of an oncoming vehicle
4. Reduce speed before turning or applying the brakes. Ensure that both brake pedals are locked together when traveling at road speeds or when on public roads. Brake both wheels simultaneously when making an emergency stop.

12. Keep the tractor in the same gear when going downhill as would be used when going uphill. Do not coast or freewheel down hills.

OPERATING THE TRACTOR

1. Apply the parking brake, place the PTO control in the 'OFF' position, the lift control lever in the down position, the remote control valve levers in the neutral position and the transmission lever in neutral before starting the tractor.
2. Do not start the engine or operate controls while standing beside the tractor. Always sit in the tractor seat when starting the engine or operating the controls.

-
3. Do not bypass the neutral start switches. Consult your authorized dealer if your neutral start controls malfunction. Use jump cables only in the recommended manner. Improper use can result in a tractor runaway.
 4. Avoid accidental contact with the gear shift levers while the engine is running. Unexpected tractor movement can result from such contact.
 5. Do not get off the tractor while it is in motion.
 6. Shut off the engine and PTO and apply the parking brake before getting off the tractor.
 7. Do not park the tractor on a steep incline.
 8. Do not run the tractor engine in an enclosed building without adequate ventilation. Exhaust fumes are toxic and can cause death.
 9. Always wear a protective mask when working with toxic spray chemicals. Follow the directions on the chemical container.
 10. If the power steering or engine ceases operating, stop the tractor immediately as the tractor will be more difficult to control.
 11. Stop the engine and relieve pressure before connecting or disconnecting hydraulic, steering or fuel lines.
 12. Tighten all connections before starting the engine or pressurizing lines.
 13. Pull only from the swinging drawbar or the lower link drawbar in the lowered position. Use only a drawbar pin that locks in place. Pulling from the tractor rear axle or any point above the axle may cause the tractor to overturn.
 14. If the front end of the tractor tends to rise when heavy implements are attached to the three-point hitch, install front end or front wheel weights. Do not operate the tractor with a light front end.
 15. Always select Position Control when attaching implements and when transporting equipment. Be sure hydraulic couplers are properly installed and will disconnect safely in case of accidental detachment of the implement.
 16. Do not leave equipment in the raised position when the vehicle is stopped or unattended.
 17. Ensure any attached equipment or accessories are correctly installed, are approved for use with the tractor, do not overload the tractor and are operated and maintained in accordance with the instructions issued by the equipment or accessory manufacturer.
 18. Remember that your tractor, if abused or incorrectly used, can be dangerous and become

a hazard both to the operator and to bystanders. Do not overload or operate with attached equipment which is unsafe, not designed for the particular task or is poorly maintained.

19. The tractor is designed to provide the minimum noise level at the operator's ears and meets or exceeds applicable standards in this respect. However, noise (sound pressure level) in the workplace can exceed 86 dB(A) when working between buildings or in confined spaces. Therefore, it is recommended that operators wear suitable ear protectors during vehicle operation.

OPERATING THE PTO

1. When operating PTO driven equipment, shut off the engine and wait until the PTO stops before getting off the tractor and disconnecting the equipment.
2. Do not wear loose clothing when operating the power take-off or especially when near rotating equipment.
3. When operating stationary PTO driven equipment, always apply the tractor parking brake and block the rear wheels front and back.
4. To avoid injury, do not clean, adjust, unclog or service PTO driven equipment when the tractor engine is running.
5. Make sure the PTO guard is in position at all times and always replace the PTO cap when the PTO is not in use.

SERVICING THE TRACTOR

1. The cooling system operates under pressure which is controlled by the radiator cap. It is dangerous to remove the cap while the system is hot. Always turn the cap slowly to the first stop and allow the pressure to escape before removing the cap entirely.
2. Do not smoke while refueling the tractor. Keep any type of open flame away. Wait for the engine to cool before refueling.
3. Keep the tractor and equipment, particularly brakes and steering, maintained in a reliable and satisfactory condition to ensure your safety and comply with legal requirements.
4. To prevent fire or explosion, keep open flames away from battery or cold weather starting aids. To prevent sparks which could cause explosion, use jumper cables according to instructions.
5. Stop the engine before performing any service on the tractor.

-
6. Escaping diesel/hydraulic fluid under pressure can penetrate the skin causing serious injury.
 - **Do not** use your hand to check for leaks. Use a piece of cardboard or paper to search for leaks.
 - Stop the engine and relieve pressure before connecting or disconnecting lines.
 - Tighten all connections before starting the engine.
 - If fluid is injected into the skin obtain medical attention immediately.
 7. Do not modify or alter or permit anyone else to modify or alter the tractor or any of its components or any tractor function without first consulting an authorized dealer.
 8. The fuel oil in the injection system is under high pressure and can penetrate the skin. Unqualified persons should not remove or attempt to adjust a pump, injector, nozzle or any other part of the injection system. Failure to follow these instructions can result in serious injury.
 9. Continuous long term contact with used engine oil may cause skin cancer. Avoid prolonged contact with used engine oil. Wash skin promptly with soap and water.

DIESEL FUEL

1. Under no circumstances should gasoline, alcohol or blended fuels be added to diesel fuel. These combinations can create an increased fire or explosive hazard. In a closed container such as a fuel tank these blends are more explosive than pure gasoline. Do not use these blends.
2. Never remove the fuel cap or refuel with the engine running or hot.
3. Do not smoke while refueling the tractor or when standing near fuel. Keep any type of open flame away. Wait for the engine to cool before refueling.
4. Maintain control of the fuel filter pipe nozzle when filling the tank.

5. Do not fill the fuel tank to capacity. Allow room for expansion.
6. Wipe up spilled fuel immediately.
7. Always tighten the fuel tank cap securely.
8. If the original fuel tank cap is lost, replace it with an approved cap. A non-approved cap may not be safe.
9. Keep equipment clean and properly maintained.
10. Do not drive equipment near open fires.
11. Never use fuel for cleaning purposes.
12. Arrange fuel purchases so that summer grade fuels are not used in the winter.

ROPS

Your tractor may be equipped with a safety frame (ROPS) which must be maintained in a serviceable condition. Be careful when driving through doorways or working in confined spaces with low headroom.

1. Do not modify, drill, weld or alter the ROPS in any way.
2. Never attempt to straighten or weld the ROPS or retaining brackets which have suffered damage. By doing so you may weaken the structure and endanger your safety.
3. Do not secure any parts on the ROPS or attach it with other than the special high tensile bolts and nuts specified.
4. Never attach chains or ropes to the safety frame or roll bar for pulling purposes.
5. Never take unnecessary risks even though your safety frame or roll bar affords you the maximum protection possible.
6. Whenever possible, operate with the ROPS in its fully upright and locked position.

IDENTIFICATION DECALS

A vehicle identification plate is located under the tractor hood. In addition, if your tractor is equipped with optional four wheel drive, a similar plate is affixed to the rear surface of the front axle housing.

For convenience, the numbers shown on the plates should be recorded and given to your authorized New Holland dealer in the event the tractor requires service.

New Holland de México S.A. de C.V. MADE IN MEXICO 05/24/99		
TRACTOR NUMBER	MODEL	UNIT
<input style="width: 90%;" type="text"/>	<input style="width: 90%;" type="text"/>	<input style="width: 90%;" type="text"/>
ENGINE	TRANSMISSION	REAR AXLE
<input style="width: 90%;" type="text"/>	<input style="width: 90%;" type="text"/>	<input style="width: 90%;" type="text"/>
HYDRAULIC PUMP	HYDRAULIC LIFT	ENGINE DATE
<input style="width: 90%;" type="text"/>	<input style="width: 90%;" type="text"/>	<input style="width: 90%;" type="text"/>
SPECIAL ORDER:		
<input style="width: 90%;" type="text"/>		
<small>XXXXXXXXXXXXXXXXXXXX</small>		

Vehicle Identification Plate

20024998

AXLE TYPE	SERIAL N°	
<input style="width: 90%;" type="text"/>	<input style="width: 90%;" type="text"/>	
CARRARO N°	CUSTOMER N°	TOTAL RATIO
<input style="width: 90%;" type="text"/>	<input style="width: 90%;" type="text"/>	<input style="width: 90%;" type="text"/>
INPUT ROTATION	DIFERENTIAL TYPE	
<input style="width: 90%;" type="text"/>	<input style="width: 90%;" type="text"/>	
<input style="width: 90%;" type="text"/>	DIFF.	
<input style="width: 90%;" type="text"/>	EPIC.	
CARRARO		

MADE IN ITALY

Front Axle Identification Plate

SAFETY DECALS (North America Only)

The following safety decals have been placed on your machine in the areas indicated. They are intended for your personal safety and for those working with you. Please take this manual and walk around your machine to note the content and location of these warning signs. Review these warning signs

and the operating instructions detailed in this manual with your machine operators.

Keep the decals legible. If they are not, obtain replacements from your authorized dealer. The decal replacement part numbers are listed with each decal.

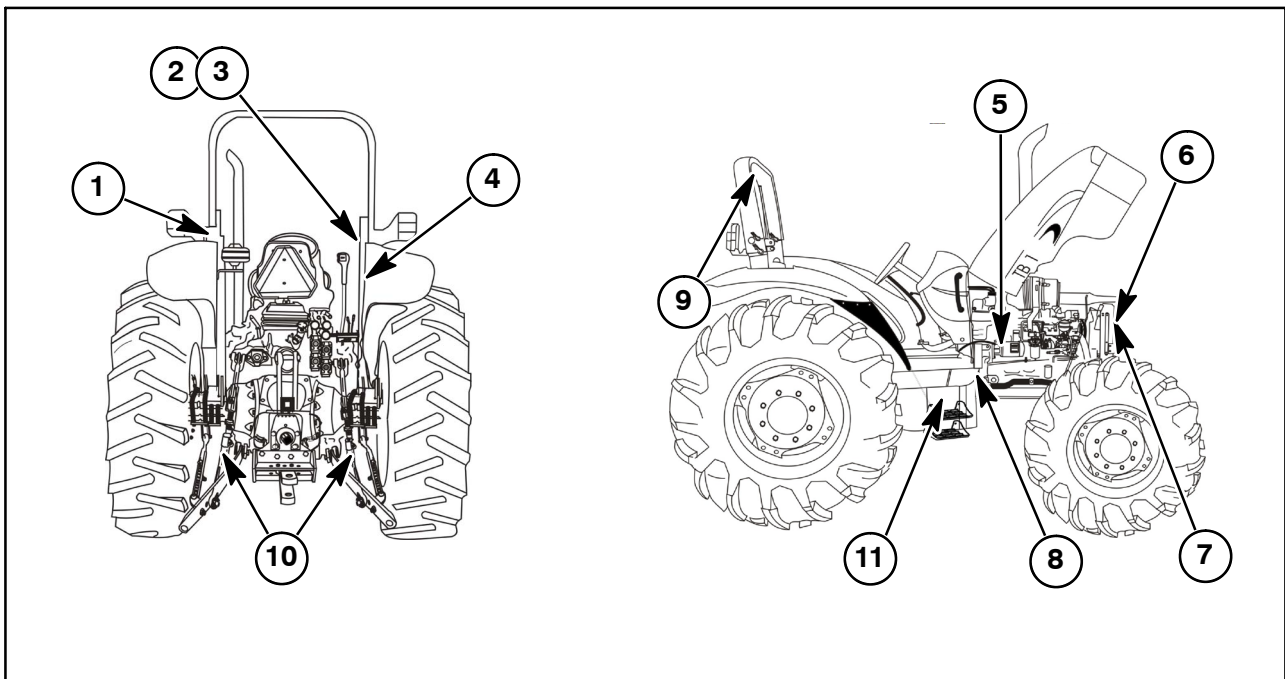

DANGER

- When improperly operated a tractor can rollover or upset.
- For low clearance use only, the ROPS can be lowered. No protection is provided in the lowered position.
- Raise ROPS and insert locking pins immediately after low clearance use, or for transport.
- When ROPS is lowered, use of seat belt is not recommended.
- Do not attach ropes or chains to ROPS for pulling purposes.
- Do not operate vehicle without ROPS locking pins in position.
- Do not attempt to fold ROPS when a canopy is fitted.
- Use of ROPS and seat belt reduce the chance of injury or death if rollover or upset occurs.

86543806

9

WARNING

- BEFORE STARTING AND OPERATING

KNOW THE OPERATING AND SAFETY INSTRUCTIONS IN THE OPERATOR'S MANUAL OF THE TRACTOR.

CLEAR THE AREA OF BAYSTANDERS.

LOCATE AND KNOW OPERATION OF CONTROLS.

FASTEN YOUR SEAT BELT.

- START ENGINE ONLY FROM OPERATOR'S SEAT WITH TRANSMISSION IN NEUTRAL, PTO DISENGAGED AND HYDRAULIC CONTROLS IN LOWERED POSITION.
- AVOID ACCIDENTAL CONTACT WITH GEAR SHIFT LEVER WHILE ENGINE IS RUNNING. UNEXPECTED TRACTOR MOVEMENT CAN RESULT.
- SLOWDOWN ON TURNS, ROUGH GROUND AND SLOPES TO AVOID UPSET.
- DO NOT PERMIT ANYONE BUT THE OPERATOR TO RIDE ON THE TRACTOR. THERE IS NO SAFE PLACE FOR RIDERS.
- LOCK BRAKES TOGETHER. USE WARNING LIGHTS AND SIGNALS WHILE DRIVING ON ROADS.
- LOWER EQUIPMENT. PLACE GEARSHIFT LEVERS IN NEUTRAL. STOP ENGINE AND APPLY PARKING BRAKE AND DISENGAGE PTO LEVER BEFORE LEAVING TRACTOR SEAT.

FAILURE TO FOLLOW ANY OF THE INSTRUCTIONS ABOVE CAN CAUSE SERIOUS INJURY TO THE OPERATOR OR OTHER PERSONS.

5179865

1

NOTE

DO NOT STOP ENGINE WITH TRANSMISSION IN CREEPER GEAR TO AVOID STARTING DIFFICULTIES

DO NOT USE CREEPER GEAR FOR HIGH DRAFT LOADS

4

WARNING

U.P.I. 8394674

10

WARNING

Lift releases or drops completely when front raise/lower lift control is operated.

DO NOT stand on implement or between implement and tractor while operating front raise/lower lift control or injury may result.

2

DANGER

- * START ENGINE ONLY FROM OPERATOR'S SEAT IF SAFETY SWITCH IS BYPASSED. ENGINE CAN START WITH TRANSMISSION IN GEAR.
- * DO NOT CONNECT OR SHORT ACROSS TERMINALS ON STARTER SOLENOID.
- * ATTACH BOOSTER CABLES AS SHOWN ON BATTERY DECAL.
- * STARTING IN GEAR CAUSING HUMANNY CAN RESULT IN SERIOUS INJURY.

6218282

5

CAUTION

HOT ENGINE

COOLANT UNDER PRESSURE

6295083

6

WARNING

Keep hands and clothing away from rotating fan and belts.

Contact with moving parts may cause

XX X 88532907

7

WARNING

HOT EXHAUST SYSTEM

- DO NOT TOUCH AND DO NOT SERVICE FILTER UNTIL COOL.
- FAILURE TO COMPLETE THE SERVICE MAY RESULT IN INJURY.

8

3

WARNING

- Pull only from drawbar. Pulling from any other point can cause overturn.
- Do not operate with unshielded PTO.
- Disengage PTO and stop engine before servicing tractor or implements.
- Position drawbar at 14" from end of PTO shaft to drawbar hole for 540 and 16" for 1000 PTO RPM.
- When towing equipment use a safety chain.

FAILURE TO FOLLOW ANY OF THE INSTRUCTIONS ABOVE CAN CAUSE SERIOUS INJURY TO THE OPERATOR OR OTHER PERSONS.

86532904

⚠ DANGER/POISON

Shield eyes
Explosive gases
can cause blindness
or serious injury



Proteger sus ojos.
Gases explosivos
pueden causar ceguera
o serias lesiones.

- ⚡ NO SPARKS
- ⚡ NO FLAMES.
- ⚡ NO SMOGING



- ⚡ NO CHISPAS
- ⚡ NO FLAMAS
- ⚡ NO FUMAR

⚠ PELIGRO/MENENO

Sulfuric acid
can cause blindness
or severe burns



Acido sulfúrico
puede causar ceguera
o severas quemaduras.

Flush eyes immediately
with water and get
medical help fast.



Enjuague sus ojos
inmediatamente con
agua y obtenga ayuda
médica rápidamente.

KEEP OUT OF THE REACH OF CHILDREN
DO NOT TIRKEEP VENT CAPS TIGHT AND LEVEL

MANTENGASE ALEJADO DEL ALCANCE LOS NIÑOS
CON LOS TAPONES APRETADOS Y A NIVEL NO VOLTEAR.

⚠ WARNING

TO JUMP START: (Negative Grounded Battery)

- 1.- Shield eyes.
- 2.- Connect end of one cable to positive (+) terminals of each battery.
- 3.- Connect one end to negative (-) terminal of "good battery".
- 4.- Connect other end to engine block.

TO PREVENT DAMAGE to other electrical components on vehicle being started, make certain that engine is idle speed before disconnecting jumper cables.

⚠ CUIDADO

PARA PASAR CORRIENTE:

(Polo negativo conectado a tierra)

- 1.- Proteja sus ojos.
- 2.- Conectar los extremos de un cable a las terminales positivas (+) de cada batería.
- 3.- Conectar el otro cable a la terminal negativa (-) de la batería "cargada".
- 4.- Conectar el otro extremo al monobloque del vehículo.

PARA PREVENIR DAÑO A otros componentes eléctricos del vehículo a ser encendido asegúrese que el motor esté en bajas r.p.m antes de desconectar los cables.

82983001

11

Thank you so much for reading.
Please click the “Buy Now!”
button below to download the
complete manual.



After you pay.

You can download the most
perfect and complete manual in
the world immediately.

Our support email:

ebooklibonline@outlook.com