

NEW HOLLAND 62LB 72LB

For TM Series Tractors
(Replaces 86978741)

87051820

9/04

OPERATOR'S MANUAL



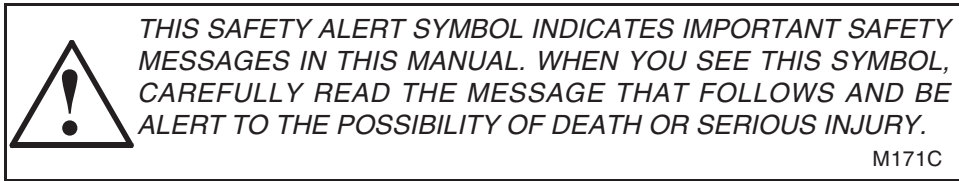

NEW HOLLAND



If Safety Decals on this machine use the words **Danger, Warning or Caution**, which are defined as follows:

- **DANGER:** Indicates an immediate hazardous situation that, if not avoided, will result in death or serious injury. The color associated with Danger is RED.
- **WARNING:** Indicates a potentially hazardous situation that, if not avoided, could result in death or serious injury. The color associated with Warning is ORANGE.
- **CAUTION:** Indicates an potentially hazardous situation that, if not avoided, may result in minor or moderate injury. It may also be used to alert against unsafe practices. The color associated with Caution is YELLOW.

If Safety Decals on this machine are ISO two panel pictorial, decals are defined as follows:

- The first panel indicates the nature of the hazard.
- The second panel indicates the appropriate avoidance of the hazard.
- Background color is YELLOW.
- Prohibition symbols such as   and  if used, are RED.



WARNING

IMPROPER OPERATION OF THIS MACHINE CAN CAUSE DEATH OR SERIOUS INJURY. BEFORE USING THIS MACHINE, MAKE CERTAIN THAT EVERY OPERATOR:

- Is instructed in safe and proper use of the machine.
- Reads and understands the Manual(s) pertaining to the machine.
- Reads and understands ALL Safety Decals on the machine.
- Clears the area of other persons.
- Learns and practices safe use of machine controls in a safe, clear area before operating this machine on a job site.

It is your responsibility to observe pertinent laws and regulations and follow CNH America LLC instructions on machine operation and maintenance.

GENERAL TABLE OF CONTENTS

1 - TO THE OWNER	1
62LB AND 72LB FRONT END LOADER	1
TO THE OWNER	2
2 - IDENTIFICATION NUMBER AND MAIN MACHINE COMPONENTS	3
SERIAL NUMBER	3
MACHINE MAIN COMPONENTS	4
3 - SAFETY/DECALS	5
SAFETY	5
SERVICE AREA, FIRE EXTINGUISHER, FIRST AID KIT	9
SAFETY DECALS	11
4 - GENERAL/SETUP INFORMATION	13
ECOLOGY AND THE ENVIRONMENT	13
TORQUE SPECIFICATIONS	14
HYDRAULIC FITTINGS	15
GENERAL INFORMATION	17
UNCRATING INSTRUCTIONS	18
AXLE OSCILLATION STOPS	22
5 - TRACTOR/LOADER CONNECTIONS	23
MOUNTING THE LOADER	23
MOUNTING THE QUICK ATTACH PLATE TO THE LOADER	27
MOUNTING THE QUICK ATTACH BUCKET	29
REMOVING THE QUICK ATTACH BUCKET	30
6 - OPERATION	39
MACHINE OPERATION	39
GRAPPLE OPERATION	49
7 - TROUBLESHOOTING	61
TROUBLESHOOTING	61
8 - LUBRICATION AND MAINTENANCE	65
ENVIRONMENT	65
PLASTIC AND RESIN PARTS	65
GENERAL SAFETY AND TRACTOR MAINTENANCE INFORMATION	65
LOADER LUBRICATION	66
BUSHING REPLACEMENT	68
HYDRAULIC CYLINDER SEAL REPLACEMENT	74
9 - STORAGE	79
STORING THE LOADER	79
REMOVING FROM STORAGE	80
10 - SPECIFICATIONS	81
SPECIFICATIONS	81
DETAIL INDEX	89

62LB AND 72LB FRONT END LOADER

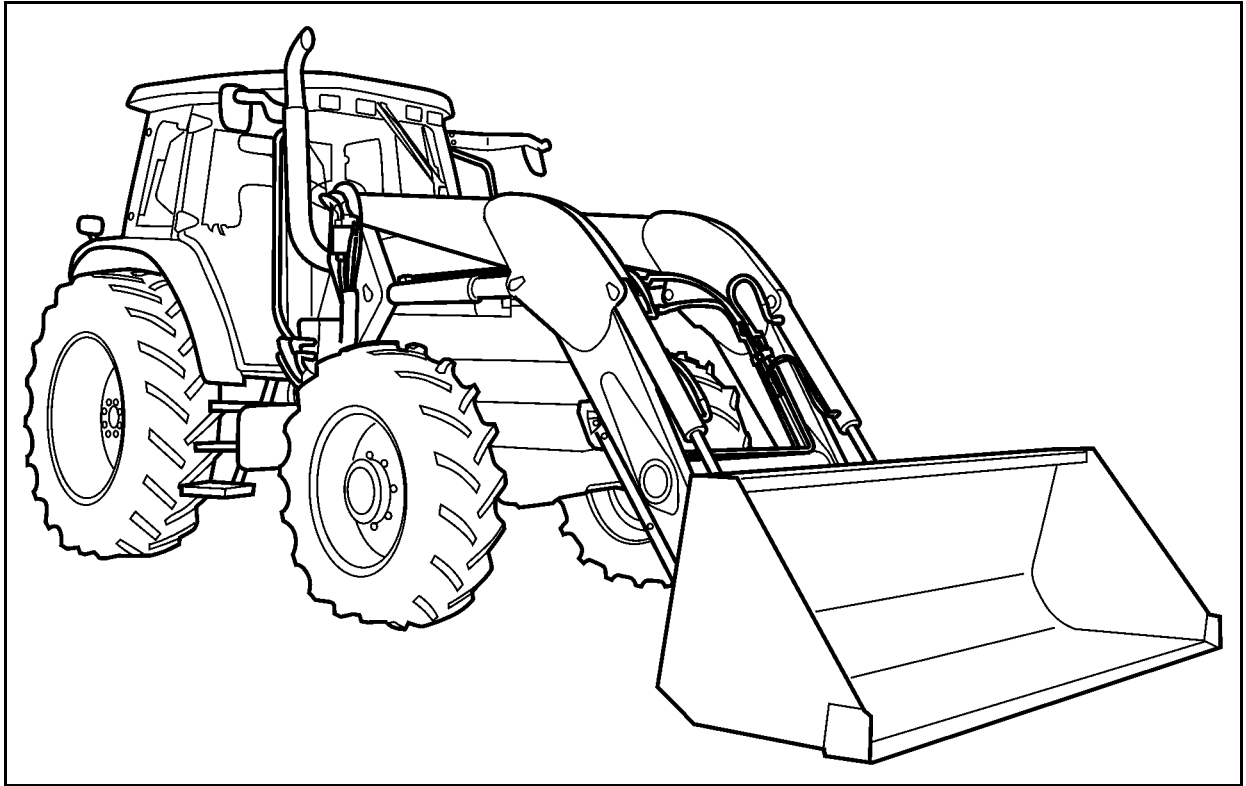

10020537

NOTE: *The Left and Right sides of the machine are the same as your Left and Right hand while seated in the Tractor Operator's Seat facing forward.*

The 62LB and 72LB Front End Loader are designed to be used with the TM Series Tractor.

TO THE OWNER

This manual contains important information about the safe operation, adjustment and maintenance of your Front End Loader. Refer to the Detail Index at the end of this manual for locating specific items about your machine.

DO NOT operate or permit anyone to operate or service this machine until you or the other persons have read this manual. Use only trained operators who have demonstrated the ability to operate and service this machine correctly and safely.

This Front End Loader, with standard equipment and authorized attachments, is intended to be used for above ground digging, land leveling, loading and material handling.

DO NOT use this machine for any application or purpose other than those described in this manual. Consult an authorized dealer or the manufacturer on changes, additions or modifications that can be required for this machine to comply with various country regulations and safety requirements. Unauthorized modifications may cause serious injury or death. Anyone making such unauthorized modifications is responsible for the consequences.

This Operator's Manual is to be stored in the Tractor Operator's Manual Storage Compartment. Make sure this manual is complete and in good condition. Contact your dealer to obtain additional manuals. Contact your dealer for any further information or assistance about your machine. Your dealer has manufacturer approved service parts. Your dealer has technicians with special training that know the best methods of repair and maintenance for your Front End Loader.

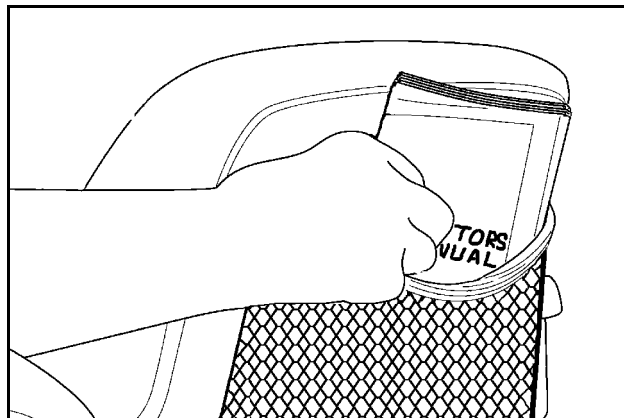

20033351

SERIAL NUMBER

When ordering parts or when requesting information or assistance always give the following information:

1. Machine Name
2. Model Number
3. Serial Number

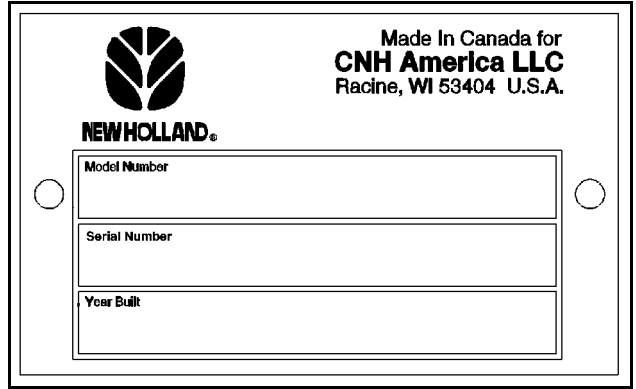

RH04A027

SERIAL NUMBER PLATE

Write the model and Serial Number of your Front End Loader on the lines below:

MODEL NUMBER

LOADER SERIAL NUMBER

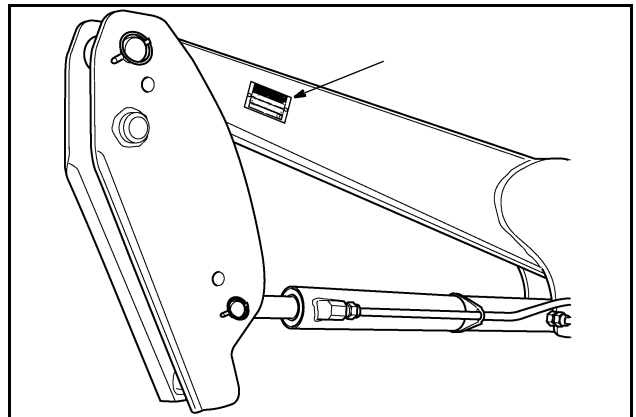

10022534

SERIAL NUMBER LOCATION

MACHINE MAIN COMPONENTS

Mechanical Self-Leveling (MSL) Loader

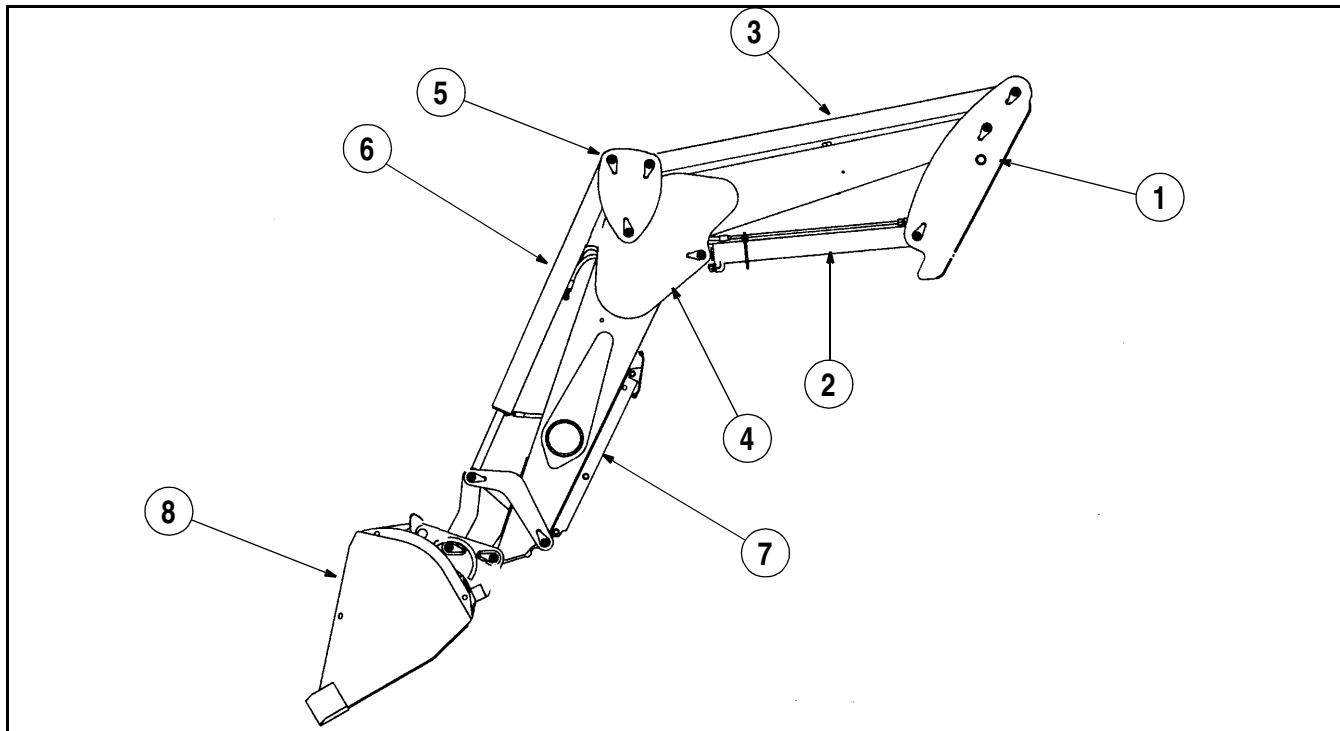

20024943

- | | |
|------------------|---------------------------|
| 1. LOADER TOWER | 5. MSL LOADER PIVOT PLATE |
| 2. LIFT CYLINDER | 6. BUCKET CYLINDER |
| 3. MSL LINK | 7. PARK STANDS |
| 4. LOADER BOOM | 8. LOADER BUCKET |

NOTE: *Mechanical Self-Leveling (MSL) Loader is shown. The Standard Loader is similar.*

SAFETY

Understand that your safety and the safety of other persons is measured by how you service and operate this machine. Know the positions and operations of all controls before you try to operate. **MAKE SURE YOU CHECK ALL CONTROLS IN A SAFE AREA BEFORE STARTING YOUR WORK.**

READ THIS MANUAL COMPLETELY and make sure you understand the controls. All equipment has a limit. Make sure you understand the stability, and load characteristics of this machine before you start to operate.

The safety information given in this manual does not replace safety codes, insurance needs, federal, state and local laws. Make sure your machine has the correct equipment needed by the local laws and regulations.

CNH America LLC is continuing to work for your safety by making machines with better protection and by giving these rules for safe operation.



*THIS SAFETY ALERT SYMBOL INDICATES IMPORTANT SAFETY MESSAGES IN THIS MANUAL. WHEN YOU SEE THIS SYMBOL, CAREFULLY READ THE MESSAGE THAT FOLLOWS AND BE ALERT TO THE POSSIBILITY OF DEATH OR SERIOUS INJURY.*M171C



GENERAL SAFETY RULES



- Before starting engine study Operator's Manual safety messages. Read all safety signs on machine. Clear the area of other persons. Learn and practice safe use of controls before operating. It is your responsibility to understand and follow manufacturers instructions on machine operation, service, and to observe pertinent laws and regulations. Operator and Service Manuals may be obtained from your equipment dealer. R103A
- ALWAYS make sure working area is clear of other persons before you start operating this machine. NEVER allow anybody in work area during machine operation or servicing.
- DO NOT modify the machine. Unauthorized modifications may cause operational malfunction or safety hazard.
- ALWAYS make sure working area is clear of other persons, pets, tools, etc. before you start operating this machine. NEVER allow anybody in work area during machine operation.
- Keep service area clean and dry. Wet or oily floors are slippery. Wet areas can be dangerous when working with electrical equipment. Be sure all electrical outlets and tools are properly grounded.
- Before leaving the machine, stop the engine, place all controls in neutral, engage the parking brake and remove the key. M581A
- A frequent cause of personal injury or death is persons falling off and being run over. Do not permit anyone to ride on the machine. M265A
- Hydraulic oil or diesel fuel leaking under pressure can penetrate the skin and cause infection or other injury.
To Prevent Personal Injury:
Relieve all pressure, before disconnecting fluid lines or performing work on the hydraulic system. Before applying pressure, make sure all connections are tight and components are in good condition.
Never use your hand to check for suspected leaks under pressure.
Use a piece of cardboard or wood for this purpose.
If injured by leaking fluid, see your doctor immediately. M149C

 **PERSONAL SAFETY** 



RH02F040



Throughout this manual and on the machine's safety decals, you will find precautionary statements: **DANGER**, **WARNING** or **CAUTION** followed by specific instructions or ISO two panel safety pictorial symbols. These precautions are intended for your personal safety.

Failure to follow the **DANGER**, **WARNING** or **CAUTION** instructions may result in death or serious bodily injury.

DANGER, **WARNING** or **CAUTION** are defined as follows:

- **DANGER:** Indicates an immediate hazardous situation that, if not avoided, will result in death or serious injury. The color associated with Danger is RED.
- **WARNING:** Indicates a potentially hazardous situation that, if not avoided, could result in death or serious injury. The color associated with Warning is ORANGE.
- **CAUTION:** Indicates a potentially hazardous situation that, if not avoided, may result in minor or moderate injury. It may also be used to alert against unsafe practices. The color associated with Caution is YELLOW.

ISO two panel **pictorial symbol decals** are defined as follows:

- The first panel indicates the nature of the hazard.
- The second panel indicates the appropriate avoidance of the hazard.
- Background color is YELLOW.
- Prohibition symbols such as   and  if used, are RED.



GENERAL TRACTOR SAFETY RULES



- Operate the Tractor only from the operator's seat.
- Use approved rollover protection and seat belt for safe operation. Overturning a Tractor without an approved roll bar could result in death or serious injury. If the Tractor is not equipped with the proper rollover protection, see your dealer to obtain the proper parts. If the Tractor is equipped with a cab, make certain the cab is approved for rollover protection.
- Always use the seat belt on Tractors equipped with a roll bar or cab. DO NOT use a seat belt if operating the Tractor without a roll bar or cab.
- Add the recommended wheel ballast and or rear weights as recommended in the Operator's Manual to provide adequate stability when using a Loader.
- Position the wheels to the Tractor manufacturer's widest recommended settings to increase stability.
- Move and turn the Tractor at low speeds.
- Before starting the engine, be sure all operating controls are in the NEUTRAL or PARK position. This will eliminate accidental movement of the machine or start up of power driven equipment.
- Before leaving the Tractor, stop the engine, put all controls in NEUTRAL or PARK, engage the park brake and remove the key.
- When transporting the Loader, engage the Loader control neutral lock to prevent accidental cycling of the Loader.



GENERAL LOADER SAFETY RULES



- Improper use of a Loader can cause death or serious injury.
- NEVER use the Loader to lift or carry anyone with the bucket, frame or attachment. Death or serious injury could result from falling off the Tractor or Loader during transport or operation.
- NEVER allow anyone to get under the Loader bucket or reach through the lift arms when the bucket is in the raised position.
- DO NOT walk or work under a raised Loader, bucket or attachment unless it is securely blocked or held in position. Accidental movement of a control lever or a leak in the hydraulic system could cause the main frame to drop or attachment to dump causing death or serious injury.
- Make sure all dismantled Loaders on park stands are on a hard level surface with all safety devices engaged to prevent the parked Loader from falling and being damaged or injuring someone.
- DO NOT repair, remove or replace any parts of the Loader while in the dismantled, parked position.
- ELECTROCUTION HAZARD - Avoid overhead wires and obstacles when the Loader is raised. Contacting overhead electrical lines can cause severe electrical burns or death from electrocution. make sure sufficient clearance is available before raising the Loader.



GENERAL OPERATING SAFETY RULES



- The equipment owner is responsible to make sure all operators read this manual thoroughly and understand the safety precautions and proper operating procedures. Be sure all operators are qualified before allowing operation of the equipment.
- Always check with proper authorities for underground utilities before digging.
- Exercise caution when operating the Loader with a raised bucket or attachment.
- Avoid loose fill, rocks and holes. These are dangerous condition for Loader operation or transport.
- Use caution when operating on steep grades. Always carry the bucket or attachment in the lowest possible position to maintain maximum stability. Select the proper gear BEFORE attempting to travel on a steep grade. Avoid shifting on grades and never “free wheel”.
- Be sure to allow for the length of the Loader when making turns or working in confined areas.
- Stop the Loader arms gradually when raising or lowering the Loader.
- Carry the bucket or attachment as low as possible to increase visibility during transport.
- When parked or during servicing of the Loader, lower the bucket to the ground, stop the engine, set the park brake and remove the key. Special care should be taken to park or store attachments with sharp points or edges in a safe manner.
- DO NOT operate Loader controls unless properly seated in the Operator’s Seat.
- NEVER attempt to handle large, heavy objects such as large round or rectangle bales, logs or oil drums unless the specific special attachments are used. Handling such objects is not recommended without special equipment.
- Handling large heavy objects can be dangerous due to the following:
 - A. Danger of overturning the Tractor
 - B. Danger of upending the Tractor
 - C. Danger of the object rolling or sliding down the Loader arms onto the operator
- If handling large heavy objects must be performed adhere to the following:
 - A. Always use the proper attachment
 - B. Never lift the load higher than necessary to clear the ground while moving
 - C. Ballast the rear of the Tractor to compensate for the weight of the load
 - D. Never lift large or heavy objects with equipment that does not have an anti-rollback device
 - E. Move slowly and carefully, avoiding rough or uneven terrain
- Loader lift capacity and break-away capacity diminish as the Loader height is increased. Use care not to grasp more material than the loader is designed to handle.

SERVICE AREA, FIRE EXTINGUISHER, FIRST AID KIT

IMPORTANT: *Keep the area used for servicing the machine clean and dry. Wet or oily floors are slippery. Wet spots can be dangerous when working with electrical equipment. Be sure all electrical outlets and tools are properly grounded.*

It is recommended that you have a Fire Extinguisher and a First Aid Kit in your maintenance area.



RH01N064

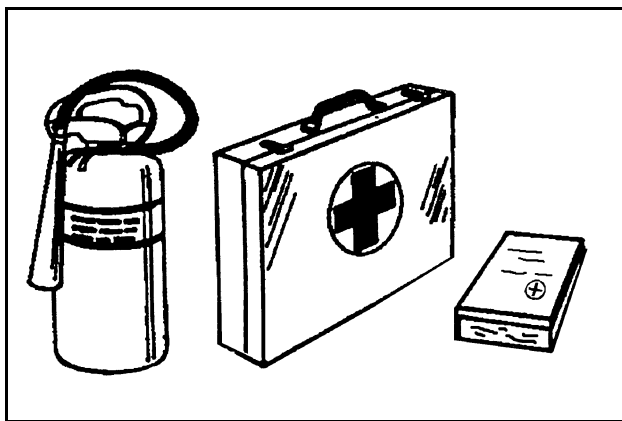

RH99E028



MAINTENANCE SAFETY



- Always wear eye protection when servicing or repairing the machine.
- Always keep safety and informational decals clean and visible. Replace decals that are damaged, lost, painted over or can not be read.
- When assembling, operating or servicing the machine, wear protective clothing and personal safety devices that are necessary for the particular procedure. Some personal safety devices that may be necessary are protective shoes, face and/or eye protection, hard hat, heavy gloves, filter mask and hearing protection.
- DO NOT wear jewelry or loose fitting clothing that may get caught in moving parts. Always wear close fitting clothing. Keep hands, feet, clothing and hair away from moving parts.
- When servicing the machine, always have the machine on a firm level surface.
- Keep the area used for servicing the machine clean and dry. Wet or oily floors are slippery. Wet spots can be dangerous when working with electrical equipment. Be sure all electrical outlets and tools are properly grounded.
- DO NOT tamper with or change the relief valve settings. The relief valve is preset at the manufacturer for optimum performance and safety. Changing the settings may cause overloading of the Tractor hydraulic system resulting in equipment failure and/or serious injury.
- When servicing or replacing the pins in the cylinder ends, bucket, etc., always use a brass drift. Failure to do so could result in equipment damage and/or personal injury due to flying metal fragments.

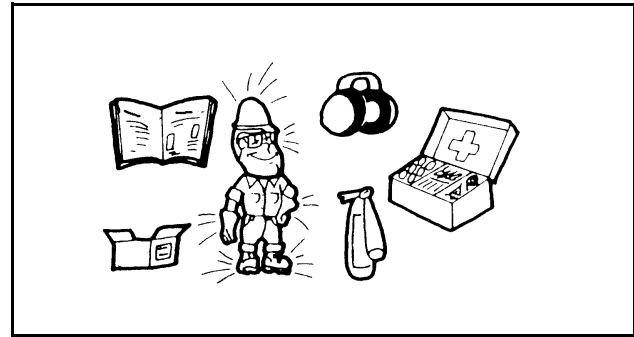

RH99E030

Thank you so much for reading.
Please click the “Buy Now!”
button below to download the
complete manual.



After you pay.

You can download the most
perfect and complete manual in
the world immediately.

Our support email:

ebooklibonline@outlook.com