

NEW HOLLAND

TL80A

TL90A

TL100A

June 2006 Production and Later

87557826 10/06

# OPERATOR'S MANUAL

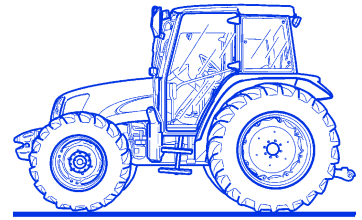

NEW HOLLAND

---

# TO THE OWNER

This manual contains information concerning the adjustment and maintenance of your New Holland TL80A, TL90A, and TL100A tractor. You have purchased a dependable machine, but only by proper care and operation can you expect to receive the performance and long service built into this tractor. Please have all operators read this manual carefully and keep it available for ready reference.

Your New Holland dealer will instruct you in the general operation of your tractor. (Refer to the “Delivery Report” at the back of this manual.) Your dealer’s staff of factory-trained service technicians will be glad to answer any questions that may arise regarding the operation of your tractor.

Your New Holland dealer carries a complete line of genuine New Holland service parts. These parts are manufactured and carefully inspected to insure high quality and accurate fitting of any necessary replacement parts. Be prepared to give your dealer the model and PIN of the tractor, when ordering parts. Locate these numbers now and record them below. Refer to the “General Information” section of this manual for the location of the model and PIN of your tractor.

Model \_\_\_\_\_

Product Identification Number (PIN) \_\_\_\_\_



---

 **WARNING** 

**This safety alert symbol indicates important safety messages in this manual. When you see this symbol, carefully read the message that follows and be alert to the possibility of personal injury or death.**

---

---

 **WARNING** 

**Pictures in this manual may show protective shielding open or removed to better illustrate a particular feature or adjustment.**

**Be certain, however, to close or replace all shielding before operating the machine.**

---

## IMPROVEMENTS

CNH America LLC is continually striving to improve its products. We reserve the right to make improvements or changes when it becomes practical and possible to do so, without incurring any obligation to make changes or additions to the equipment sold previously.

---

# CONTENTS

	Section - Page
<b>Section 1</b>	
General Information and Safety .....	1-1
Notices for the User .....	1-1
Tractor Identification .....	1-2
Important Ecological Considerations .....	1-5
Precautionary Statements .....	1-6
Working Safely .....	1-8
Safety Decals .....	1-14
Standardized Symbols .....	1-19
<b>Section 2</b>	
General Information, Controls and Instruments .....	2-1
Introduction .....	2-1
Control Panel .....	2-3
Operating Controls .....	2-28
Lever Controls .....	2-33
Cab .....	2-40
Heated, Ventilated and Air Conditioned Cab .....	2-49
Air Conditioning Ventilation and Heating (Cab Models) .....	2-51
Gearbox Transmission .....	2-57
Transmission With Range Gear and Shuttle - 30 Km/H (18.64 Mph) (12 Forward Gears + 12 Reverse Gears - Synchro Shuttle) .....	2-58
Transmission With Creeper and Shuttle - 30 Km/H (18.64 Mph) (20 Forward Gears + 12 Reverse Gears - Synchro Shuttle) .....	2-60
Transmission With Electro-hydraulic Dual Command/Power-shuttle 30/40 Km/H (18.64/24.85 Mph) (24 F + 24 R) .....	2-62
Fast Transmissions 40 Km/H (TLA Deluxe Models with FWD) .....	2-69

---

### Section 3

Field Operation .....	3-1
Starting and Stopping .....	3-2
Brakes .....	3-11
Power Take-off .....	3-13
Hydraulic Lift .....	3-17
Three-point Linkage .....	3-20
Implement Linkage Points .....	3-24
Remote Auxiliary Control Valves .....	3-25
Wheel Track Adjustment .....	3-29
Steering Angle Adjustment .....	3-33
Tires .....	3-37
Loading Index .....	3-43
Speed Code .....	3-43
Inflation Pressures .....	3-44
Tire Sizes .....	3-45
Tire Combinations .....	3-47
Specified Combinations for FWD Models .....	3-48
Tire Inflation Pressures for FWD Models .....	3-49
Ballast .....	3-50
Liquid Ballasting .....	3-51
Maximum Permitted Weights .....	3-55
Four Wheel Drive Models .....	3-56

---

## **Section 4**

Lubrication and Maintenance .....	4-1
Running-in Period .....	4-2
Tractor Refuelling .....	4-3
Access for Inspection and Maintenance .....	4-5
Lubrication and Maintenance Table .....	4-6
When the Indicator Light Illuminates on the Dashboard .....	4-8
Every 10 Hours of Work .....	4-11
Every 50 Hours of Work .....	4-15
Every 300 Hours of Work .....	4-19
Every 600 Hours of Work .....	4-23
Every 1200 Hours of Work or Every Year .....	4-25
Every 1200 Hours or Every 2 Years .....	4-26
Every 1800 Hours of Work .....	4-31
General Maintenance .....	4-32
Electrical System - General Information .....	4-35
Fuses and Relays .....	4-37
Bodywork Recommendations .....	4-48
Lubricants and Fluids Table .....	4-49

## **Section 5**

Troubleshooting .....	5-1
Locating and Identifying Problems .....	5-1

## **Section 6**

Tractor Storage .....	6-1
-----------------------	-----

---

**Section 7**

Accessories ..... 7-1

Towing Equipment ..... 7-2

Fold-down ROPS ..... 7-4

Joystick for Auxiliary Control Valves (Optional) ..... 7-5

Joystick for Auxiliary Control Valves (Walvoil) (Serial Number HJS026057 and Above) ..... 7-7

**Section 8**

Specifications and Data ..... 8-1

Engine Data ..... 8-6

**Section 9**

Delivery Report ..... 9-1

First 50 Hour Service ..... 9-5

Inspections and/or Operations to be Carried Out ..... 9-5

**Section 10**

Index ..... 10-1

---

# FEDERAL EMISSIONS WARRANTY

## (North America Only)

(California owner's emissions warranty is covered elsewhere)

CNH UK Ltd warrants that your new 1996 and later heavy-duty off-road diesel engine was designed, built, and equipped to conform to applicable U.S. Environmental Protection Agency regulations for a period of use of five years or 3,000 hours of operation, whichever occurs first.

The new model year, class of diesel engine, and emission application determination for your engine are identified on the emission control information label affixed to the engine. The warranty period begins on the date the new equipment is sold to the first retail purchaser.

Any emission control system parts which are proven defective during normal use will be repaired or replaced during the warranty period. The warranty repairs and service will be performed by any authorized CNH dealer at the dealer's place of business, with no charge for parts or labor (including diagnosis).

As the engine owner, you are responsible to perform all the required maintenance listed in your owner's manual. CNH UK Ltd will not deny an emission warranty claim solely because you have no record of maintenance; however, a claim may be denied if your failure to perform maintenance resulted in the failure of a warranted part. Receipts covering regular maintenance should be retained in the event of questions and these receipts should be passed on to each subsequent owner of the engine.

It is recommended replacement parts used for maintenance or repairs be CNH Service Parts to maintain the quality originally designed into your emission certified engine. The use of non-CNH parts does not invalidate the warranty on other components unless the use of such parts causes damage to warranted parts.

CNH UK Ltd wishes to assure the emission control systems warranty is being properly administered. If you believe you have not received the service entitled to under this warranty, you should contact the nearest CNH Office for assistance. The address and phone number of each Office is in your equipment owner's manual. If additional assistance or information is needed, contact:

Service Department  
CNH America, LLC  
500 Diller Avenue  
New Holland, PA 17557  
(717) 355-1121

Please note that the Emission Warranty does not cover:

1. Systems and parts that were not first installed on the new equipment or engine as original equipment by CNH UK Ltd.
2. Part malfunctions caused by abuse, misuse, improper adjustment, modification, alteration, tampering, disconnection, improper or inadequate maintenance, or use of non-recommended fuels and lubricating oils.
3. Accident caused damage, acts of nature, or other events beyond CNH UK Ltd's control.
4. Replacement of expendable items made in connection with scheduled maintenance.
5. Parts requiring replacement, inspection or adjustment maintenance intervals for reasons other than being defective.
6. Parts which are not CNH Service Parts.
7. Loss of time, inconvenience, loss of use of equipment/engine or commercial loss.
8. Equipment with altered or disconnected hourmeter where the hours cannot be determined.
9. Equipment normally operated outside the United States.
10. Non-defective parts replaced by other than CNH dealers.

### Coverage

This emission control system warranty applies only to the following emission control parts.

Electronic Control Unit  
Fuel Injection Pump  
Fuel Injectors  
Turbocharger  
Intake Manifold  
Exhaust Manifold  
Boost Pressure Tubing-connection to Aneroid Device ON F.I.P.

---

# CALIFORNIA EMISSION CONTROL WARRANTY STATEMENT

(North America Only)

(California Only)

## Your Warranty Rights and Obligations

The California Air Resources Board and CNH UK LTD are pleased to explain the emission control system warranty on your engine. In California, new 2004 and later heavy-duty off-road engines from 50 to 750 HP must be designed, built and equipped to meet the State's stringent anti-smog standards. CNH UK LTD must warrant the emission control system on your engine for the periods of time listed below, provided there has been no abuse, neglect or improper maintenance of your engine.

Your emission control system includes parts such as the fuel injection system and the air induction system.

Where a warrantable condition exists, CNH UK LTD will repair your heavy-duty off-road engine at no cost to you including diagnosis, parts and labor.

### Manufacturer's Warranty Coverage:

The 2004 and later heavy-duty off-road engines are warranted from the original date of delivery for five years or 3000 hours of operation, whichever occurs first. If any emission-related part on your engine is defective, the part will be repaired or replaced by CNH UK LTD.

### Owner's Warranty Responsibilities:

- As the heavy-duty off-road engine owner, you are responsible for the performance of the required maintenance listed in your owner's manual. CNH UK LTD recommends that you retain all receipts covering maintenance on your heavy-duty off-road engine, but CNH UK LTD cannot deny warranty solely for the lack of receipts or for your failure to ensure the performance of all scheduled maintenance.
- As the heavy-duty off-road engine owner, you should, however, be aware that CNH UK LTD may deny you warranty coverage if your heavy-duty off-road engine or a part has failed due to abuse, neglect, improper maintenance or unapproved modifications.
- Your engine is designed to operate on commercially available diesel fuel only. Use of any other fuel may result in your engine no longer operating in compliance with California's emissions requirements.
- You are responsible for initiating the warranty process. The ARB suggests that you present your heavy-duty off-road engine to a CNH dealer as soon as a problem exists. The warranty repairs should be completed by the dealer as expeditiously as possible.
- If you have any questions regarding your warranty rights and responsibilities, you should contact your nearest CNH Office at the address and telephone number listed on the Owner Assistance page of your equipment's operator manual.
- Prior to the expiration of the warranty, you must give notice of any failure of an emission control warranted part. Such notice must be given to CNH UK LTD or an authorized CNH dealer, and you must deliver the engine to the repair location.
- You, the owner, are responsible for incidental costs incurred by yourself or your employees as a result of an unwarrantable failure. Examples of such costs are communication expenses, meals and lodging.
- The owner is responsible for any business costs or losses, any "downtime" expenses and any "cargo" damage which result from the failure of a warranted part. CNH UK LTD is not responsible for other incidental or consequential damages, including, but not limited to fines, theft, vandalism or collisions.

### Parts covered:

This emission control system warranty applies to the following emission control parts:

Electronic Control Unit	Intake Manifold
Fuel Injection Pump	Charge Air Cooler
Fuel Injectors	Exhaust Manifold
Turbocharger	Boost Pressure Tubing (connection to Aneroid Device on F.I.P.)

Any replacement part, equivalent in performance and durability, may be used in the performance of any maintenance or repairs and must be provided without charge to the owner. The use of these parts does not reduce the warranty obligations of CNH UK LTD. However, CNH UK LTD recommends the use of new, genuine CNH service parts or CNH approved rebuilt parts and assemblies. CNH UK LTD also recommends that the engine be serviced by a CNH authorized dealer.

### CNH UK LTD Responsibilities:

Warranty work will be provided at no charge to the owner at any authorized dealer, using genuine CNH service parts or CNH approved rebuilt parts or assemblies.

The owner will not be charged for diagnostic labor which leads to the determination that a warranted part is defective, if the diagnostic work was performed at a warranty station.

CNH UK LTD is liable for damages to other engine components caused by the failure under warranty of any warranted part.

### Warranty Limitations

CNH UK LTD is not responsible for failures resulting from abuse or neglect by owner or operator.

CNH UK LTD warrants to the ultimate purchaser and each subsequent purchaser that the engine is designed, built, and equipped so as to conform with all applicable regulations adopted by the Air Resources Board, and that it is free from defects in materials and workmanship which cause the failure of a warranted part.

Any warranted part which is not scheduled for replacement as required maintenance, or which is scheduled only for regular inspection to the effect of "repair or replace as necessary" is warranted for the warranty period.

Any warranted part which is scheduled for replacement as required maintenance is warranted for the period of time prior to the first scheduled replacement point of that part.

CNH UK LTD is not liable to warrant failures caused by the use of add-on or modified parts.

CNH UK LTD is concerned to ensure proper maintenance of the engine to maximize emissions performance. Information on care and replacement of engine air cleaner, and all other aspects of engine maintenance is provided in a manual supplied to the owner. A maintenance schedule chart is provided in the manual.



---

**(North America Only)**  
**(California Only)**

**CALIFORNIA**

**Proposition 65 Warning**

**Diesel engine exhaust and some of its constituents are known to the State of California to cause cancer, birth defects, and other reproductive harm.**

**Battery posts, terminals and related accessories contain lead and lead compounds, chemicals known to the State of California to cause cancer and birth defects or other reproductive harm. Wash hands after handling.**

---

# SECTION 1

## GENERAL INFORMATION AND SAFETY

### NOTICES FOR THE USER

#### GENERAL GUIDELINES

This Operator's Manual provides a guide for the user with regard to running-in, use and maintenance of the tractor.

Read this manual carefully and keep in a convenient place for future reference. Do not hesitate to contact your local dealer for any queries concerning your tractor. The dealer can provide skilled personnel, trained by the manufacturer, original service parts and all tools and equipment necessary for your service requirements.

The tractor is designed as a power generator and drive-propulsion unit for use in normal and traditional agricultural conditions.

The tractor is also designed to provide maximum performance, economic running and easy use over a wide range of operations. Prior to delivery, all machines are carefully inspected (by both the Manufacturer and your local authorized dealer), to make sure that they reach the user in perfect condition. To maintain the tractor in this condition and ensure trouble-free operation, the routine maintenance described in Section 4 of this manual must be carried out at the specified intervals.

#### CLEANING THE TRACTOR

Your tractor is an advanced machine, fitted with an electrohydraulic control system. Care must be taken when cleaning the tractor, especially if a pressurized water cleaner is used.

- Never stand too close to the tractor or direct the water jet on electrical components, seals or intake openings, etc.
- Never direct jets of cold water at the hot engine or exhaust. See (RECOMMENDATIONS FOR BODYWORK MAINTENANCE) in Section 4.

#### SAFETY

Safety precautions for the operator and bystanders are shown in Section 1 and throughout manual inclusive. Read the safety instructions and follow recommendations and hints **before** starting to use the tractor.

#### SERVICE AFTER THE FIRST 50 HOURS OF WORK

The operations required for the first service are shown at the end of the Manual, immediately prior to the index.

After the first 50 hours of use, return to the dealer with your tractor and this Manual in order to carry out the Manufacturer's checks and to fill in the certificates included in Section 9. The first sheet (page 5) must be compiled on completion of the service and held by the dealer. The second sheet (page 7) must be kept in the Manual for documentation and reference purposes. **Check that both copies are signed by both yourself and the dealer.**

#### SPARE PARTS

"Non-original" spare parts have not been tested or authorized by the Manufacturer. Installment and/or use of such products may adversely affect the tractor's design specifications, thereby compromising operational safety. The manufacturer cannot be held responsible for any damage resulting from the use of "non-original" spare parts.

No modifications may be made to the tractor without written authorization from the Manufacturer.

#### WARRANTY

The tractor is guaranteed in accordance with current legislation in your country and in line with contractual agreements reached with the dealer at the time of sale. However, the warranty is no longer valid if the rules and instructions for the use and maintenance of the tractor, described in this Manual, are not observed.

# TRACTOR IDENTIFICATION

Product identification numbers (pin) identify the tractor and its main components. The identification data must be supplied by the dealer for requests for spare parts or service operations. Identification data is of fundamental importance in the event of theft of the tractor. The location of the various identification data is shown below.

TYPE
CHASSIS
HOMOLOGATION
ENGINE
NEW HOLLAND N.A. INC NEW HOLLAND PENNSYLVANIA MADE IN ITALY

20040407  
**Frame and engine type summary data plate (located under the steering wheel)**

**Tractor frame number identification data plate (stamped on the axle support under the hood).**

☆ 0000000000 ☆

MDF1430A

**Frame identification data plate.**

NEW HOLLAND	SAFETY STRUCTURE	TYPE/MODEL	Italy
	STRUCTURE TESTED	D.E.C.D. REPORT	
S:	TH	CSHA:	Madras
FRANCE MARQUAGE STRUCTURE	SF: TS - N°	DK: GODKENDT AF DIREKTØREN FOR ARBEJDSLØSYNET	
VEHICLE WEIGHT FOR SAE TEST	Kg	LB	GB:
STRUCTURE SERIAL	N°		

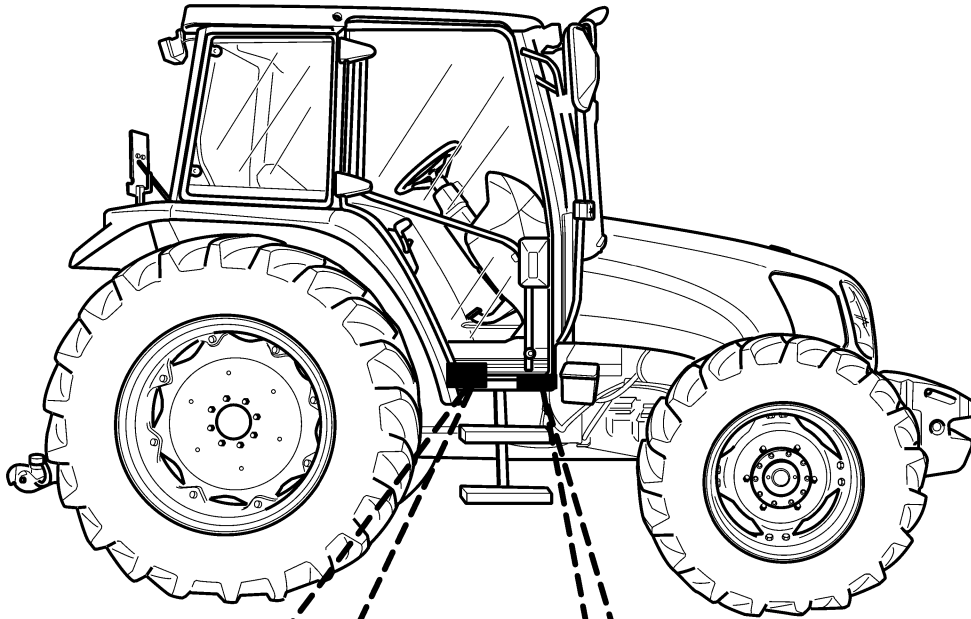

MDF0867A

**Frame and engine type identification data plate (inside the cab).**

[ ]	
TYPE	
[ ]	
⊙	CHASSIS
[ ]	
HOMOLOGATION	
[ ]	
ENGINE	
[ ]	[ ]
NEW HOLLAND N.A. INC NEW HOLLAND PENNSYLVANIA MADE IN ITALY	

**Cab identification data plate.**

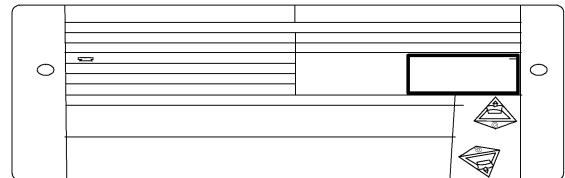

20040407

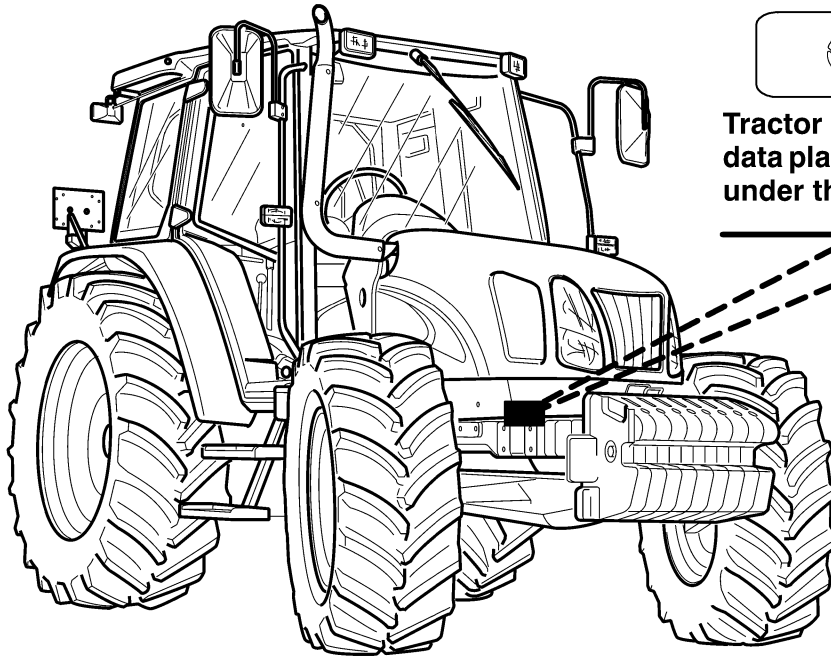

☆ 000000000 ☆

Tractor frame number identification data plate (stamped on the axle support under the hood).

MDF0879A

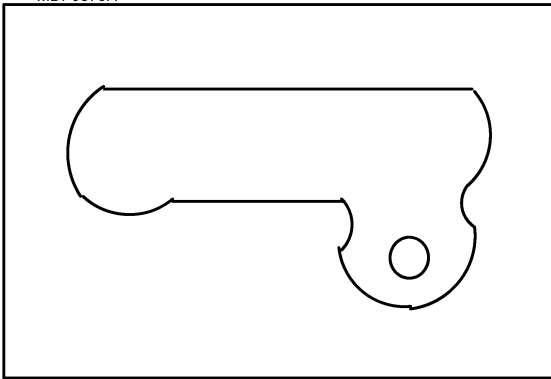

Engine identification data plate (on engine body).

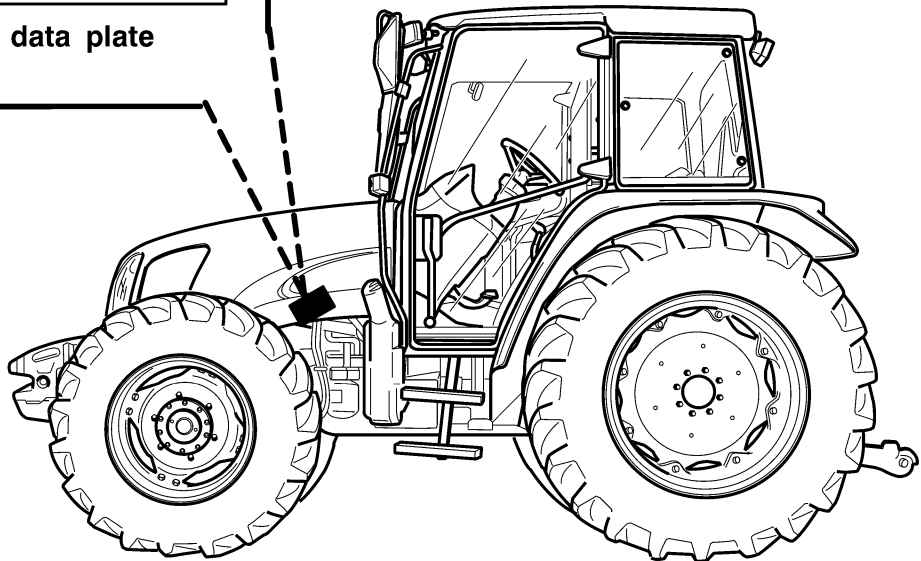

MDF0868A

Thank you so much for reading.  
Please click the “Buy Now!”  
button below to download the  
complete manual.



After you pay.

You can download the most  
perfect and complete manual in  
the world immediately.

Our support email:

[ebooklibonline@outlook.com](mailto:ebooklibonline@outlook.com)