

**LX116 Loaders for
D35, D40, D45, DX35, DX40,
DX45 Tractors**

Operator's Manual

87571255
Replaces 87300944

CASE *III*

TO THE OWNER

This manual contains information concerning the adjustment and maintenance of your Case IH Model LX116 Loader. You have purchased a dependable machine, but only by proper care and operation can you expect to receive the performance and long service built into this loader. Please have all operators read this manual carefully and keep it available for ready reference.

Your Case IH dealer will instruct you in the general operation of your loader. (Refer to the "Delivery Report" at the back of this manual.) Your dealer's staff of factory-trained service technicians will be glad to answer any questions that may arise regarding the operation of your loader.

Your Case IH dealer carries a complete line of genuine Case IH service parts. These parts are manufactured and carefully inspected to insure high quality and accurate fitting of any necessary replacement parts. Be prepared to give your dealer the model and PIN of the tractor and loader, when ordering parts. Locate these numbers now and record them below. Refer to the "General Information" section of this manual for the location of the model and PIN of your loader.

Loader Model _____ Tractor Model _____
Loader PIN _____ Tractor PIN _____

PIN PLATE

CNH America LLC Racine, WI 53404 U.S.A.	
CASE IH [®]	Made In U.S.A.
Model Number	
Product Identification Number	
Year Built	

50046503



This safety alert symbol indicates important safety messages in this manual. When you see this symbol, carefully read the message that follows and be alert to the possibility of personal injury or death.



Pictures in this manual may show protective shielding open or removed to better illustrate a particular feature or adjustment.

Be certain, however, to close or replace all shielding before operating the machine.

IMPROVEMENTS

CNH America LLC is continually striving to improve its products. We reserve the right to make improvements or changes when it becomes practical and possible to do so, without incurring any obligation to make changes or additions to the equipment sold previously.

CONTENTS

SAFETY	0-5
GENERAL INFORMATION	1-1
OPERATION	2-1
MAINTENANCE/LUBRICATION AND ASSEMBLY	3-1
TROUBLESHOOTING	4-1
SPECIFICATIONS	5-1
INDEX	5-7
DELIVERY REPORT	5-9

CALIFORNIA

Proposition 65 Warning

Diesel engine exhaust and some of its constituents are known to the State of California to cause cancer, birth defects, and other reproductive harm.

Battery posts, terminals and related accessories contain lead and lead compounds, chemicals known to the State of California to cause cancer and birth defects or other reproductive harm. Wash hands after handling.

PRECAUTIONARY STATEMENTS

PERSONAL SAFETY

Throughout this manual and on machine decals, you will find precautionary statements (“**DANGER**”, “**WARNING**”, and “**CAUTION**”) followed by specific instructions. These precautions are intended for the personal safety of you and those working with you. Please take the time to read them.



DANGER



This word “**DANGER**” indicates an immediate hazardous situation that, if not avoided, will result in death or serious injury. The color associated with Danger is RED.



WARNING



This word “**WARNING**” indicates a potentially hazardous situation that, if not avoided, could result in death or serious injury. The color associated with Warning is ORANGE.



CAUTION



This word “**CAUTION**” indicates a potentially hazardous situation that, if not avoided, may result in minor or moderate injury. It may also be used to alert against unsafe practices. The color associated with Caution is YELLOW.

FAILURE TO FOLLOW THE “DANGER”, “WARNING”, AND “CAUTION” INSTRUCTIONS MAY RESULT IN SERIOUS BODILY INJURY OR DEATH.

MACHINE SAFETY

The precautionary statement (“**IMPORTANT**”) is followed by specific instructions. This statement is intended for machine safety.

IMPORTANT: *The word “IMPORTANT” is used to inform the reader of something he needs to know to prevent minor machine damage if a certain procedure is not followed.*

INFORMATION

NOTE: *Instructions used to identify and present supplementary information.*

SAFETY

PRECAUTIONARY STATEMENTS

A careful operator is the best operator. Most accidents can be avoided by observing certain precautions. To help prevent accidents, read the following precautions before operating this equipment. Equipment should be operated only by those who are responsible and instructed to do so.

Carefully review the procedures given in this manual with all operators. It is important that all operators be familiar with and follow safety precautions.

GENERAL

1. Read the Operator's Manual carefully before using the tractor or loader. Lack of operating knowledge can lead to accidents.
2. Replace damaged or illegible safety decals. See the Specifications section of this manual for required decals.
3. Operate the tractor and loader only from the operator's seat.

THE TRACTOR

1. Use an approved roll bar and seat belt for safe operation. Overturning a tractor without a roll bar can result in death or injury. If your tractor is not equipped with a roll bar and seat belt, see your tractor dealer.
2. Equip your tractor with FOPS (Falling Object Protective Structure) and seat belts before installing or operating the loader.
3. Always use the seat belt when the roll bar is installed. Do not use the seat belt if the roll bar is removed from the tractor.
4. Add the recommended wheel ballast and/or rear weight as recommended in the owner's manual to provide good stability.
5. Move the wheels to the tractor manufacturer's widest recommended settings to increase stability.
6. Move and turn the tractor at low speeds.

THE LOADER

1. Improper use of a loader can cause serious injury or death.
2. Do not lift or carry anybody on the loader or in the bucket or attachment.

3. Never allow anyone to get under the loader bucket or reach through the lift arms when the bucket is raised.
4. Do not walk or work under a raised loader, bucket, or attachment unless it is securely blocked or held in position.
5. Avoid overhead wires and obstacles when the loader is raised. Contacting electrical lines can cause electrocution.
6. Make sure all dismounted loaders are on a hard, level surface.
7. Do not repair, remove, or replace any parts of the loader while it is in the dismounted position.

OPERATING THE LOADER

1. It is the loader owner's responsibility to be certain that anyone operating the loader reads this manual first to be aware of the safe way of operating the loader.
2. Exercise caution when operating the loader with a raised, loaded bucket or fork.
3. Avoid loose fill, rocks, and holes. They can be dangerous for loader operation or movement.
4. Use care to maintain proper stability when operating on steep grades. Always carry the bucket in the lowest position possible.
5. Allow for the loader length when making turns.
6. Stop the loader arms gradually when lowering or lifting.

-
7. Use caution when handling loose or shiftable loads.
 8. Carry the bucket at a low position during transport for better visibility.
 9. When parking or servicing, lower the bucket to the ground, stop the engine, and set the park brakes before leaving the tractor seat.
 10. Operate the loader controls only when properly seated at the controls.
 11. Using front end loaders without special attachments for handling large heavy objects such as large round or rectangular bales, logs, and oil drums is **NOT RECOMMENDED**.
 12. Handling large heavy objects can be extremely dangerous due to:
 - danger of rolling the tractor over.
 - danger of upending the tractor.
 - danger of the object rolling or sliding down the loader arms onto the operator.
 13. If you must perform this sort of work (see #12 above), protect yourself by:
 - using the proper attachment.
 - never lifting the load higher than necessary to clear the ground when moving.
 - ballasting the tractor rear to compensate for the load.
 - never lifting large objects with equipment that does not have an anti-rollback device.
 - moving slowly and carefully, avoiding rough terrain.

MAINTENANCE

1. When servicing or replacing the pins in the cylinder ends, bucket, etc., always use a brass drift and hammer. Failure to do so could result in injury from flying metal fragments.
2. Do not modify or alter, or permit anyone else to modify or alter, the loader or any of its components or any loader function without first consulting a Case IH dealer. If you have any questions regarding loader modifications, contact Case IH.
3. Always wear safety goggles when servicing or repairing the machine.
4. Escaping hydraulic/diesel fluid under pressure can penetrate the skin, causing serious injury.
 - **DO NOT** use your hand to check for leaks.
 - Use a piece of cardboard or paper to search for leaks.
 - Stop the engine and relieve the pressure before connecting or disconnecting the hydraulic or diesel lines.
 - Tighten all connections before starting the engine or pressuring the lines.
 - If any fluid is injected into the skin, obtain medical attention **IMMEDIATELY** or gangrene may result.
5. Do not tamper with the relief valve setting. The relief valve is preset at the factory. Changing the setting can cause overloading the loader and tractor, and serious operator injury may result.



**WHEN YOU SEE THIS SYMBOL
IT MEANS:
ATTENTION!
BECOME ALERT!
YOUR SAFETY IS INVOLVED!**

SAFETY DECALS

The following safety decals have been placed on your machine in the areas indicated. They are intended for your personal safety and for those working with you. Please take this manual and walk around your machine to note the content and location of these warning signs. Review these warning signs and the operating instructions detailed in this manual with your machine operators.

Keep the decals legible. If they are not, obtain replacements from your authorized dealer. The decal replacement part numbers are listed with each decal.

IMPORTANT: Be a safe operator. Thoroughly acquaint yourself with the following before attempting to operate the loader:

1. The safety information in the tractor and loader operator's manuals.
2. The operating instructions in the operator's manual.
3. The controls on the loader and tractor.

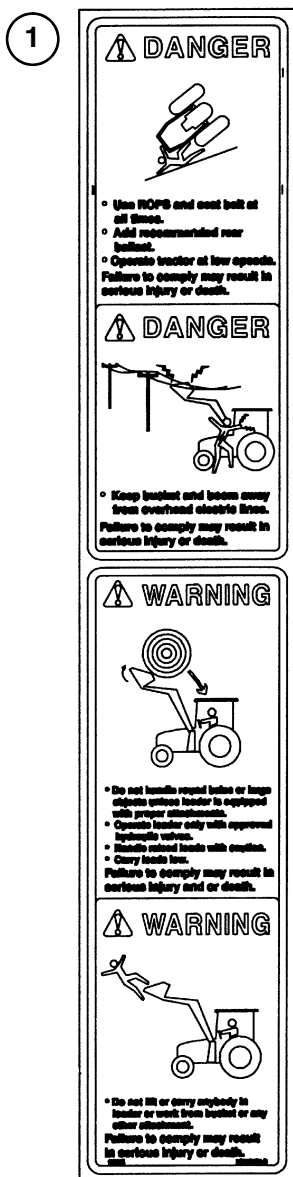

DANGER/WARNING Decal
Part No.: 86589568
Location: Right side, rear of mount upright

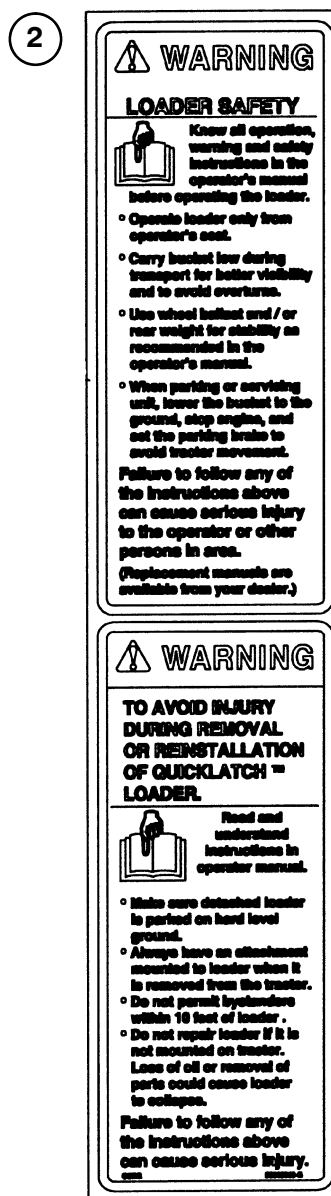

WARNING Decal
Part No.: 86589569
Location: Left side, rear of mount upright

LX116 MOUNT KIT DECAL PLACEMENT

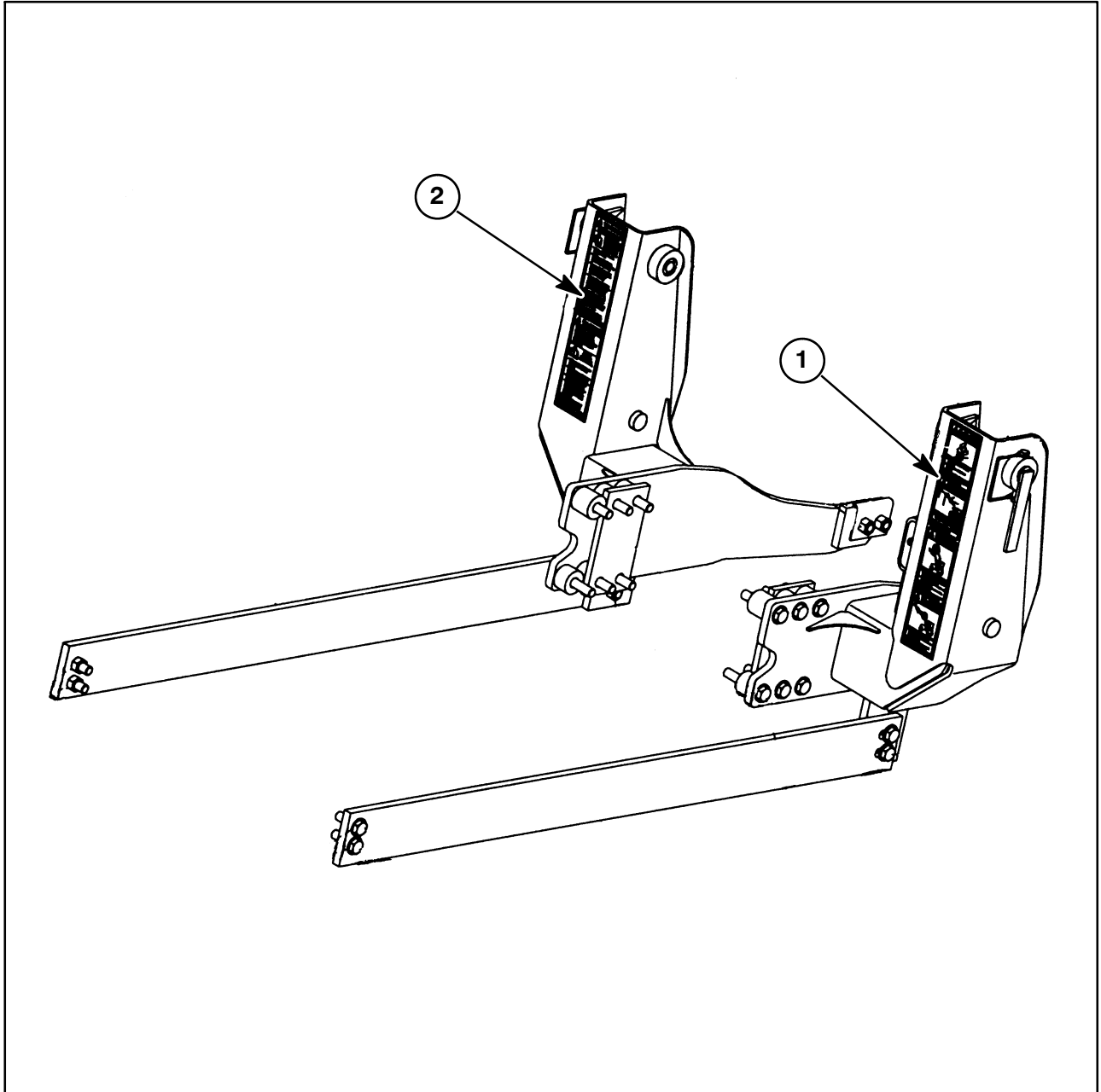

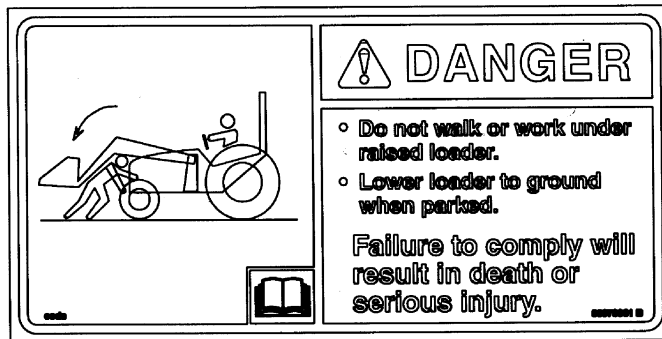

DANGER Decal
 Part No.: 86979961
 Location: Right and Left side; lower loader boom



Decal, Case IH - LX116
 Part No.: 87028688
 Location: Right side, loader boom

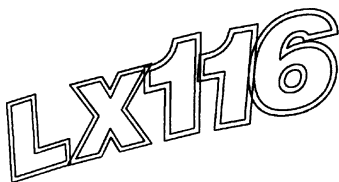

Decal, Case IH - LX116
 Part No.: 87028687
 Location: Left side, loader boom

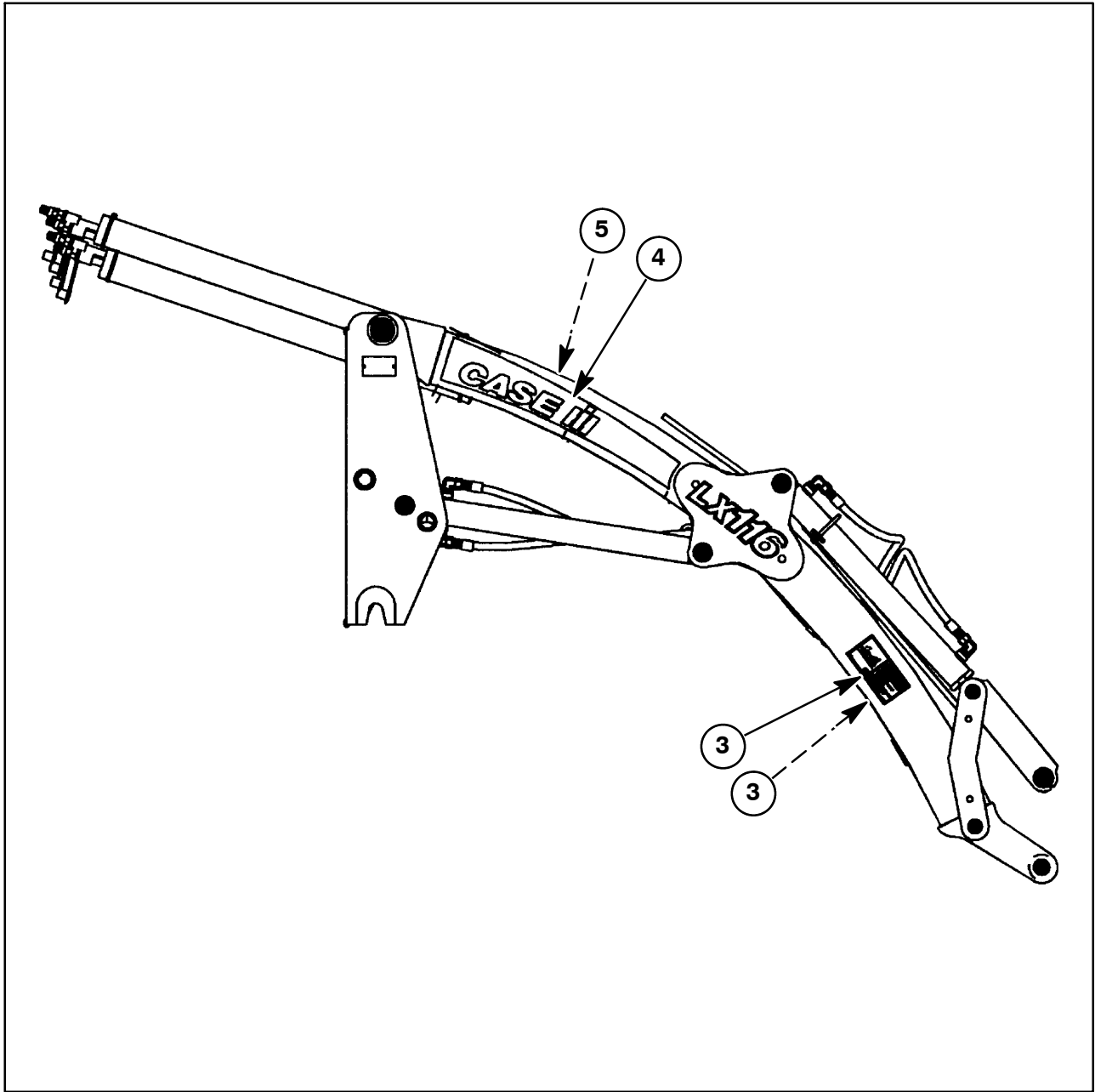

ECOLOGY AND THE ENVIRONMENT

Soil, air, and water are vital factors of agriculture and life in general. When legislation does not yet rule the treatment of some of the substances which are required by advanced technology, common sense should govern the use and disposal of products of a chemical and petrochemical nature.

The following are recommendations which may be of assistance:













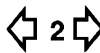







- Become acquainted with and ensure that you understand the relative legislation applicable to your country.
- Where no legislation exists, obtain information from suppliers of oils, filters, batteries, fuels, antifreeze, cleaning agents, etc., with regard to their effect on man and nature and how to safely store, use and dispose of these substances. Agricultural consultants will, in many cases, be able to help you as well.

HELPFUL HINTS

1. Avoid filling tanks using cans or inappropriate pressurized fuel delivery systems which may cause considerable spillage.
2. In general, avoid skin contact with all fuels, oils, acids, solvents, etc. Most of them contain substances which may be harmful to your health.
3. Modern oils contain additives. Do not burn contaminated fuels and or waste oils in ordinary heating systems.
4. Avoid spillage when draining off used engine coolant mixtures, engine, gearbox and hydraulic oils, brake fluids, etc. Do not mix drained brake fluids or fuels with lubricants. Store them safely until they can be disposed of in a proper way to comply with local legislation and available resources.
5. Modern coolant mixtures, i.e. antifreeze and other additives, should be replaced every two years. They should not be allowed to get into the soil but should be collected and disposed of safely.
6. Do not open the air-conditioning system yourself. It contains gases which should not be released into the atmosphere. Your dealer or air conditioning specialist has a special extractor for this purpose and will have to recharge the system properly.
7. Repair any leaks or defects in the engine cooling or hydraulic system immediately.
8. Do not increase the pressure in a pressurized circuit as this may lead to a component failure.
9. Protect hoses during welding as penetrating weld splatter may burn a hole or weaken them, allowing the loss of oils, coolant, etc.

UNIVERSAL SYMBOLS

As a guide to the operation of your tractor, various universal symbols have been utilized on the instruments, controls, switches, and fuse box. The symbols are shown below with an indication of their meaning.

	Thermostart starting aid		Radio		P.T.O.		Position Control
	Alternator charge	KAM	Keep alive memory	N	Transmission in neutral		Draft Control
	Fuel level		Turn signals		Creepers gears		Accessory socket
	Automatic Fuel shut-off		Turn signals -one trailer		Slow or low setting		Implement socket
	Engine speed (rev/min x 100)		Turn signals -two trailers		Fast or high setting		%age slip
	Hours recorded		Front wind-screen wash/wipe		Ground speed		Hitch raise (rear)
	Engine oil pressure		Rear wind-screen wash/wipe		Differential lock		Hitch lower (rear)
	Engine coolant temperature		Heater temperature control		Rear axle oil temperature		Hitch height limit (rear)
	Coolant level		Heater fan		Transmission oil pressure		Hitch height limit (front)
	Tractor lights		Air conditioner		Hitch disabled		Hydraulic and transmission filters
	Headlamp main beam		Air filter blocked		FWD engaged		Remote valve extend
	Headlamp dipped beam		Parking brake		FWD disengaged		Remote valve retract
	Work lamps		Brake fluid level		Warning!		Remote valve float
	Stop lamps		Trailer brake		Hazard warning lights		Malfunction! See Operator's Manual
	Horn		Roof beacon		Variable control		Malfunction! (alternative symbol) See Operator's Manual
			Warning! Corrosive substance		Pressurized! Open carefully		

Buy Now



Our support email:

ebooklibonline@outlook.com