

JX1070U / JX1080U / JX1090U / JX1100U

**JX1070U  
JX1080U  
JX1090U  
JX1100U  
Tractors**

Operator's Manual

87647991

**CASE *ii***

**Tractors      JX1070U, JX1080U**  
**JX1090U, JX1100U**

Use and Maintenance manual

87647991

# **SECTION SUMMARY**

**1 – Introduction and safety measures**

**2 – General Information, Controls and Instruments**

**3 – Field operation**

**4 – Lubrication and Maintenance**

**5 – Troubleshooting**

**6 – Vehicle storage**

**7 – Accessories**

**8 – Specifications and Data**

**9 – Running-in period**

**10 – Alphabetical Index**

---

## Electromagnetic Interference (EMC)

This tractor complies strictly with the European Regulations on electromagnetic emissions.

However, interference may arise as a result of add-on equipment which may not necessarily meet the required standards.

As such interference can result in serious malfunction of the unit and/or create unsafe situations, you must observe the following:

- Ensure that each piece of non CASE IH equipment fitted to the tractor bears the mark.



- The maximum power of electromagnetic emission equipment (radio, telephones, etc.) must not exceed the limits imposed by the national authorities of the country where you use the tractor.
- The electromagnetic field generated by the add-on system should not exceed 24 V/m at any time and at any location in the proximity of electronic components.

Failure to comply with these rules will render the CASE IH warranty null and void.

---

# SUMMARY

## Page

### SECTION 1 General information and safety

Notices to users .....	1-1
Tractor identification .....	1-2
Important ecological considerations .....	1-5
Always work safely .....	1-6
Working safely .....	1-7
Safety Decals .....	1-13
Standard symbols .....	1-18
Tractor noise level information sheet .....	1-19

### SECTION 2 Controls, instruments and operation

Control panel .....	2-2
Control panel .....	2-3
Programming keypad .....	2-19
Operating controls .....	2-35
Seat adjustment .....	2-38
Cab .....	2-43
Air-conditioned cab .....	2-52
Instructions for use – air conditioning system .....	2-52
Transmission with range gear – 18.64 mph (30 km/h) (12F + 4R – Synchro Command) .....	2-57
Transmission with range gear and shuttle – 18.64 mph (30 km/h) (12F + 12R – Synchro Shuttle) .....	2-60
Transmission with creeper and shuttle – 18.64/24.85 mph (30/40 km/h) (20 F + 12 R – Synchro Shuttle) .....	2-63
Transmission with Dual Command (2 Speed Power Shift) – 18.64 or 24.85 mph (30 or 40 km/h) (24 F + 12 R – Dual Command (2 Speed Power Shift)) .....	2-66
Transmission with electrohydraulic Dual Command (2 Speed Power Shift) / Power-Shuttle 18.64/24.85 mph (30/40 km/h) (24F + 24R) .....	2-69
Transmission with electrohydraulic Dual Command (2 Speed Power Shift) / Power-Shuttle and clutch 30/40 km/h (24F + 24R) .....	2-70
Fast transmissions 40 km/h .....	2-80

### SECTION 3 Field operation

Starting and stopping .....	3-2
Starting with low outside temperatures .....	3-3
Electrohydraulically controlled four-wheel drive .....	3-6
Rear differential lock .....	3-8
Front and rear differential lock .....	3-9
Brakes .....	3-11
Power take-off .....	3-17
Hydraulic lift .....	3-25
Electronically controlled hydraulic lift .....	3-29
Three-point linkage .....	3-38
Implement connection points .....	3-43

---

Remote control valves .....	3-47
Remote control valves (de luxe) .....	3-51
Wheel track adjustment .....	3-54
Steering angle adjustment .....	3-58
Tyres .....	3-62
Tyre pressures .....	3-69
Tyre combinations .....	3-72
Ballast .....	3-72
Maximum permitted weights .....	3-80

## **SECTION 4 Lubrication and Maintenance**

Access for inspection and maintenance .....	4-7
Lubrication and maintenance table .....	4-8
Flexible maintenance .....	4-11
Instrument panel warning lights .....	4-17
Every 10 hours of work .....	4-20
Every 50 hours of work .....	4-22
Every 100 hours of work .....	4-25
Every 300 hours of work .....	4-27
Every 600 hours of work .....	4-32
Every 1200 hours or every year .....	4-35
Every 1200 hours of work or every 2 years .....	4-36
Every 1800 hours of work .....	4-41
Electrical System .....	4-42
Recommendations for bodywork maintenance .....	4-59
Consumables .....	4-60

## **SECTION 5 Troubleshooting**

## **SECTION 6 Tractor storage**

## **SECTION 7 Accessories**

Quick fit implement linkage .....	7-2
Towing equipment .....	7-4
Fold-down roll bar .....	7-12
Joystick for auxiliary control valves (optional) .....	7-13
Front loader prearrangement .....	7-15
Control valve for trailer hydraulic brakes .....	7-16

## **SECTION 8 Specifications and data**

## **SECTION 9 First 50 hour Service Forms**

## **SECTION 10 Alphabetical index**

# SECTION 1

## NOTICE TO USERS

### GENERAL GUIDELINES

This Use and Maintenance Manual provides a guide for the user with regard to running-in, use and maintenance of the tractor.

Read this manual carefully and keep in a convenient place for future reference. Do not hesitate to contact your local dealer for any queries concerning your tractor. The dealer can provide skilled personnel, trained by the manufacturer, original service parts and all tools and equipment necessary for your service requirements.

The tractor is designed as a power generator and drive-propulsion unit for use in normal and traditional agricultural conditions.

The tractor is also designed to provide maximum performance, economic running and easy use over a wide range of operations. Prior to delivery, all machines are carefully inspected (by both the Manufacturer and your local authorised dealer), to make sure that they reach the user in perfect condition. To maintain the tractor in this condition and ensure trouble-free operation, the routine maintenance described in Section 3 of this manual must be carried out at the specified intervals.

### CLEANING THE TRACTOR

Your tractor is an advanced machine, fitted with an electrohydraulic control system. Care must be taken when cleaning the tractor, especially if a pressurized water cleaner is used.

- Never stand too close to the tractor or direct the water jet on electrical components, seals or intake openings, etc.
- Never direct jets of cold water at the hot engine or exhaust. See also page 4–59 (RECOMMENDATIONS FOR BODYWORK MAINTENANCE).

### SAFETY

Safety precautions for the operator and bystanders are shown on page vi to xii inclusive. Read the safety instructions and follow recommendations and hints **before** starting to use the tractor.

### FIRST 50 – HOUR SERVICE

The operations required for the first service are shown at the end of the Manual, immediately prior to the index.

After the first 50 hours of use, return to the dealer with your tractor and this Manual in order to carry out the Manufacturer's checks and to fill in the certificates included on pages 1 and 3). The first sheet (page 1) must be compiled on completion of the service and held by the dealer. The second sheet (page 3) must be kept in the Manual for documentation and reference purposes. **Check that both copies are signed by both yourself and the dealer.**

### SERVICE PARTS

"Non-original" spare parts have not been tested or authorised by the Manufacturer. Installment and/or use of such products may adversely affect the tractor's design specifications, thereby compromising operational safety. The manufacturer cannot be held responsible for any damage resulting from the use of "non-original" spare parts.

No modifications may be made to the tractor without written authorisation from the Manufacturer.

### WARRANTY

The tractor is guaranteed in accordance with current legislation in your country and in line with contractual agreements reached with the dealer at the time of sale. However, the warranty is no longer valid if the rules and instructions for the use and maintenance of the tractor, described in this Manual, are not observed.

## TRACTOR IDENTIFICATION

Serial numbers identify the tractor and its main components. The identification data must be supplied by the dealer for requests for spare parts or service operations. Identification data is of fundamental importance in the event of theft of the tractor. The location of the various identification data is shown below.

TIPO	
OMOLOGAZIONE	
TELAIO	
MASSA TOTALE AMMISSIBILE (kg)	
CARICO AMMISSIBILE SULL'ASSE ANTERIORE (kg)	DA: A:
CARICO AMMISSIBILE SULL'ASSE POSTERIORE (kg)	D.A: A:
CARICO RIVORCIABILE AMMISSIBILE	
MASSA RIVORCIABILE NON FRENATA (kg)	
MASSA RIVORCIABILE CON FRENATURA INDIPENDENTE (kg)	
MASSA RIVORCIABILE CON FRENATURA AD INERZIA (kg)	
MASSA RIVORCIABILE CON FRENATURA ASSISTITA (kg)	
NEW HOLLAND ITALIA S.p.A. MODENA ITALY MADE IN ITALY	COEFFICIENTE ASSORBIMENTO

**Frame and engine type summary data plate (located under the steering wheel).**

MDF1430B

**Tractor frame number identification data plate (stamped on the axle support under the bonnet).**

☆ 0000000000 ☆

**Frame identification data plate.**

NEW HOLLAND	SAFETY STRUCTURE	TYPE/MODEL	MODENA
	STRUCTURE TESTED		
SAE	O.E.C.O. REPORT:		MODENA
SAE	CSA:		
FRANCE MARCHANDISE STRUCTURE	TI		MODENA
SFC TS - A			
DIN 60060/EN 60060 AF (DIREKTIVEN FOR ARBEJDSSTILSYSTEM)			MODENA
VEHICLE WEIGHT FOR SAE TEST		kg LB	
STRUCTURE SERIAL		N°	MODENA



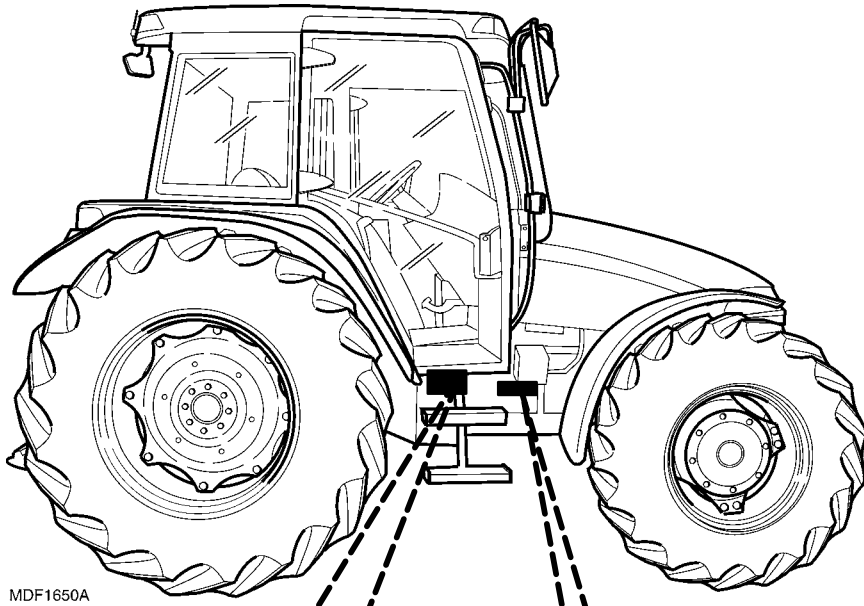

MDF1650A

Frame and engine type identification data plate (inside the cab).

TIPO	
OMLOGAZIONE	
TELAIO	
MASSA TOTALE AMMISSIBILE (kg)	
CARICO AMMISSIBILE SULL'ASSE ANTERIORE (kg)	DA:      A:
CARICO AMMISSIBILE SULL'ASSE POSTERIORE (kg)	DA:      A:
CARICO RIMORCHIABILE AMMISSIBILE	
MASSA RIMORCHIABILE NON FRENATA (kg)	
MASSA RIMORCHIABILE CON FRENATURA INDIPENDENTE (kg)	
MASSA RIMORCHIABILE CON FRENATURA AD INERZIA (kg)	
MASSA RIMORCHIABILE CON FRENATURA ASSISTITA (kg)	
NEW HOLLAND ITALIA S.p.A. MODENA ITALY MADE IN ITALY	COEFFICIENTE ASSORBIMENTO <input type="checkbox"/>

Cab identification data plate.

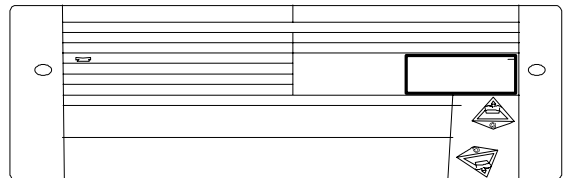

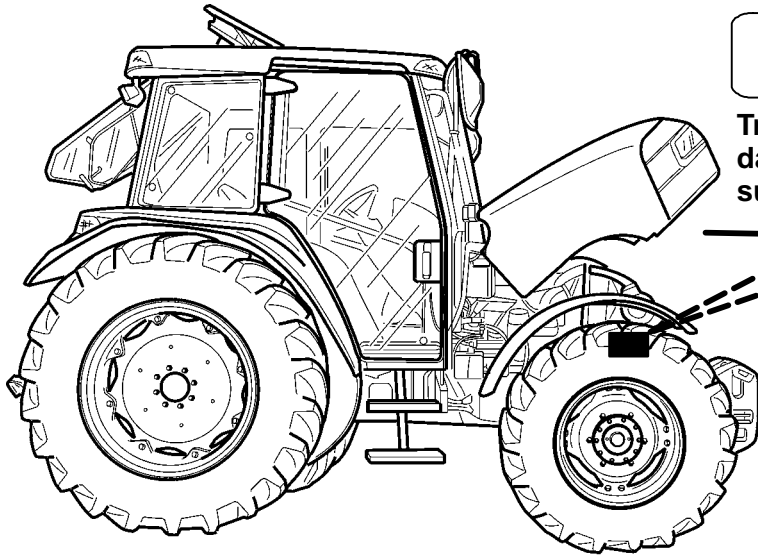

☆000000000☆

Tractor frame number identification data plate (stamped on the axle support under the bonnet).

MDF1413A

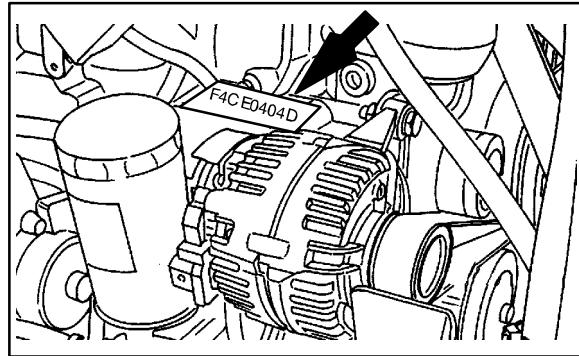

Engine identification data plate (on engine body).

NOTE: The stamped identification code is covered by protective adhesive tape.

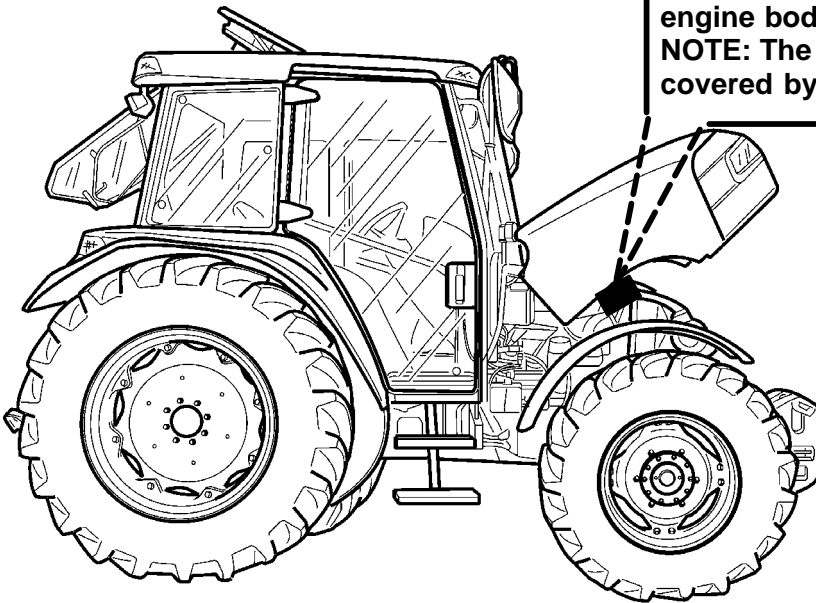

MDF1413A

## IMPORTANT ECOLOGICAL CONSIDERATIONS

Soil, air and water are essential elements for agriculture and for life in general. If local legislation does not control the treatment of certain substances, the production of which is necessitated by advanced technologies, products derived from chemical and petrochemical products must be used and disposed of according to the rules of common sense.

The following recommendations may be of help:

- Find out what the relevant legislation in your country stipulates.
- Ask your suppliers of lubricants, oils, fuels, anti-freeze, detergents, etc. for information on the effects of these products on humans and the environment and for instructions concerning their use, storage and disposal. In many cases, local agricultural consultants will be able to provide assistance.

### SUGGESTIONS

1. Avoid using unsuitable, pressurised filling systems or fuel cans when filling tanks, as these may cause considerable spillage and leakage of liquids.
2. As a general rule, do not allow liquid fuels, lubricants, acids, solvents, etc., to come into contact with the skin. The majority of these products contain substances that are potential health hazards.
3. Modern lubricants contain additives. Do not burn contaminated fuel oils and/or oils used in conventional heating systems.
4. Avoid spillage when transferring used engine cooling liquids, engine and transmission lubricants, hydraulic oils, brake fluids, etc. Never mix used brake oil with fuel oil, or fuel oil with lubricants. Store safely until suitable disposal can be arranged according to national legislation or local regulations.
5. Modern anti-freeze liquids and solutions, e.g. anti-freeze and other additives, must be replaced every two years. They must not be left to be absorbed into the ground, but must be collected and disposed of in a suitable manner.
6. Do not open the air conditioning systems to carry out work. These systems contain gas that must not be released into the atmosphere. Contact your dealer or specialised personnel, who are equipped with the appropriate equipment and are authorised to re-fill the system.
7. Any leakage or defect in the engine cooling or hydraulic systems must be repaired immediately.
8. Do not increase the pressure in pressurised systems, as this may cause component parts to burst.
9. When welding, make sure that hoses are properly protected as sparks or molten material may puncture or weaken the tubes and sleeves, resulting in leakage of oil, cooling liquid, etc.
10. Do not adjust the setting of the fuel delivery system as this will alter the emission of exhaust fumes.

**NOTE: THE ENGINES INSTALLED ON THE TRACTORS COMPLY WITH ANTI-POLLUTION LEGISLATION.**

## ALWAYS WORK SAFELY



This warning symbol points out important messages concerning your safety.

Read the following safety regulations carefully and follow the recommendations in order to avoid potential hazards and safeguard your health and safety.

In this manual the symbol is accompanied by the following key-words:



When the warning is to prevent potential damage to the machine, which could also put the operator's safety at risk.

---



This warning specifically indicates a potential danger to the user or to any other person directly involved.

---

Failure to observe the instructions preceded by the aforementioned key words (**CAUTION** and **DANGER**) may result in severe or fatal injury to the people involved.

Furthermore, this manual also contains instructions in italics preceded by the terms **NOTE** and **WARNING**, with the following relevance in relation to machine protection:

**NOTE:** Underlines the correct procedure or technique to be followed by the operator.



Informs the operator of the danger of damaging the machine if the specified procedure is not followed.

---

### **IMPORTANT WARNINGS**

The machine is designed and produced exclusively for agricultural use.

All other use will be considered to be contrary to the use specified by CASE IH, who cannot be held liable for damage to property or the machine, or for personal injuries which may result.

Persons who risk improper use will therefore assume the responsibility for any consequences arising from such use.

Compliance with the instructions for use, maintenance and repairs described in this manual, are the essential preconditions for the use specified by CASE IH.

The machine must only be used, serviced or repaired by personnel trained in the relevant working methods and safety regulations and who have been authorised to work on the machine.

The user must also observe the rules concerning general safety and accident prevention, including the Highway Code when driving on public highways.

Any arbitrary modifications made to this machine will release CASE IH from any liability resulting from damage or injury.

CASE IH and all its distribution organisations, inclusive of, but not restricted to, national, regional or local distributors, cannot be held liable for damage resulting from the malfunction of parts and/or components not approved by CASE IH.

Under no circumstances will a guarantee be issued for products made or sold by CASE IH that are damaged as a result of the malfunction of parts and/or components not approved by CASE IH.

## WORKING SAFELY

1. During the manufacturing of this tractor, every step has been taken to ensure safe operation. However, the best way to avoid accidents is to exercise caution at all times. Once the accident has already happened it is too late to remember what steps should have been taken.
2. Read this manual carefully before starting, using, carrying out maintenance, refuelling or performing any other type of operation on the tractor.
3. The time spent reading this manual will allow you to get to know your tractor, thereby saving time and effort. This will also help prevent accidents from taking place.
4. Read all the safety decals on the machine and follow the instructions thereon before starting, operating, refuelling or carrying out maintenance on the machine. Promptly replace any decals that are damaged, lost or illegible. Clean the decals if they are covered by mud or debris.
5. Remember that the tractor is exclusively designed for agricultural use. Any other use will require prior authorisation from CASE IH.
6. It is advisable to keep a first aid kit on hand.
7. The tractor must only be used by responsible personnel, trained in tractor use and authorised to operate the machine.
8. Do not alter the injection system calibration in an attempt to increase maximum engine speed.
9. Do not wear loose clothing that may be trapped in moving parts. Check that all rotating parts connected to the power take-off are correctly protected.

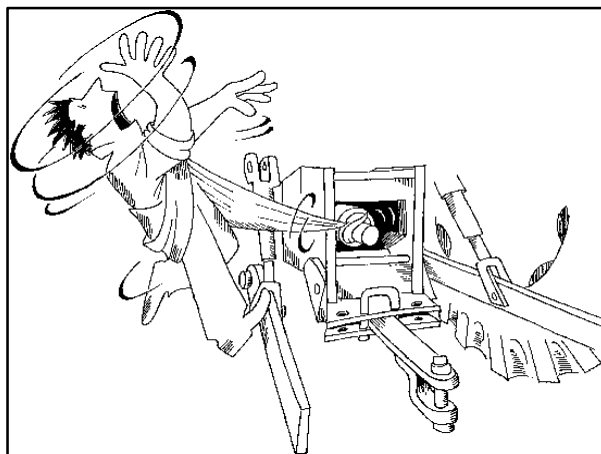

4

**Buy Now**



Our support email:

[ebooklibonline@outlook.com](mailto:ebooklibonline@outlook.com)