

**David Brown
1410 & 1412
Tractors**

Operators Manual

9-5416

Reprinted

CASE III





THIS SAFETY ALERT SYMBOL INDICATES IMPORTANT SAFETY MESSAGES IN THIS MANUAL. WHEN YOU SEE THIS SYMBOL, CAREFULLY READ THE MESSAGE THAT FOLLOWS AND BE ALERT TO THE POSSIBILITY OF PERSONAL INJURY OR DEATH.

M171B

If Safety Decals on this machine use the words **Danger, Warning or Caution**, which are defined as follows:

- **DANGER:** Indicates an immediate hazardous situation which if not avoided, will result in death or serious injury. The color associated with Danger is RED.
- **WARNING:** Indicates an potentially hazardous situation which if not avoided, will result in serious injury. The color associated with Warning is ORANGE.
- **CAUTION:** Indicates an potentially hazardous situation which if not avoided, may result in minor or moderate injury. It may also be used to alert against unsafe practices. The color associated with Caution is YELLOW.

If Safety Decals on this machine are ISO two panel Pictorial, decals are defined as follows:

- The first panel indicates the nature of the hazard.
- The second panel indicates the appropriate avoidance of the hazard.
- Background color is YELLOW.
- Prohibition symbols such as   and  if used, are RED.



WARNING

IMPROPER OPERATION OF THIS MACHINE CAN CAUSE INJURY OR DEATH. BEFORE USING THIS MACHINE, MAKE CERTAIN THAT EVERY OPERATOR:

- Is instructed in safe and proper use of the machine.
- Reads and understands the Manual(s) pertaining to the machine.
- Reads and understands ALL Safety Decals on the machine.
- Clears the area of other persons.
- Learns and practices safe use of machine controls in a safe, clear area before operating this machine on a job site.

It is your responsibility to observe pertinent laws and regulations and follow Case Corporation instructions on machine operation and maintenance.

**DAVID BROWN
1410 & 1412
Tractors
Instruction Book**



David Brown Tractors Ltd

A Tenneco Company

Affiliate of J. I. Case





WARNING!



Improper operation of this machine may result in injury or death. Before operating this machine study the **SAFETY POINTS** starting on page 2 and read this book thoroughly.



Look for this symbol which points out important safety precautions. It means **ATTENTION! BECOME ALERT! YOUR SAFETY IS INVOLVED!**

There are three degrees of safety message used in this publication. The signal words preceding the message are as follows:-
The word **CAUTION** denotes the least serious hazard.
The word **WARNING** is intermediate between caution and danger.
The word **DANGER** denotes the most serious hazard which if ignored could endanger life or limb.

David Brown policy is one of continuous development and improvement and therefore the specification details may have been altered since this book went to press.

Moreover, as the David Brown tractor is offered in a variety of forms to cover a large number of markets and applications, this handbook may contain details of items not applicable to the particular tractor for which it has been supplied.



DAVID BROWN
Instruction Book
1410 & 1412 Tractors

David Brown Tractors Limited
Meltham . Huddersfield . England . HD7 3AR

Publication 9-5416 August 1974

SAFETY POINTS

Always ensure that PTO driven implements are not run faster than their designed speed or a dangerous mechanical failure may result.

Always ensure the PTO is adequately guarded.

Always remove loose clothing when working near moving parts of the tractor, engine and implements, or ensure that it is adequately fastened or tied up.

Always remove the ignition/starter key from the tractor when leaving it unattended, especially where children have access.

Always operate the steering and driving controls with care, for example:—

Don't swerve or turn sharply at speed.

Don't let the clutch in suddenly going up hill or the tractor may rear up.

Don't brake fiercely, especially going backwards down hill.

Always take extra care on steeply sloping ground. Move cautiously, as the sudden swing of a heavy implement, or pull of a trailer, may cause trouble.

Always make sure before turning that there is room for any mounted implement which will swing *outwards* at the rear.

Always hitch trailers to the approved drawbar or pick-up hitch which is below the centre line of the rear axle. Do not hitch above the centre line.

Always tow the tractor carefully. When towing by rope with a dead engine, power steering will be inoperative and the steering will be very difficult to turn.

IMPORTANT DON'TS

Do Not carry passengers on the linkages or on the tractor, except in an approved passenger seat.

Do Not drill into the safety frame or cab.

Note: Any damaged parts should be replaced immediately with new parts. Bent parts should not be straightened but replaced and no welding should be attempted on the safety frame. Bolts when replaced, must be of the correct tensile strength. After any accident to a safety frame it is advisable to report this to your local safety officer.

Do Not lift the tractor by the cab lifting hooks. These are designed only for removing a cab from the tractor.

INTRODUCTION

We recommend that even the most experienced tractor user reads the Operation and Regular Maintenance sections of this book *before* commencing operations with his new tractor. The various tasks can in fact be performed by any but the complete novice, but this book details the easiest, quickest and most efficient ways of carrying them out.

The most important aspect, however, is *safety*, because a tractor can be a dangerous machine if handled without due caution. Knowledge gained beforehand from this book can prevent accidents.

The **1410** tractor is fitted with the David Brown sunchromesh gearbox which allows on-the-move gear changes to be made between the most useful ratios.

The **1412 Hydra-Shift** tractor incorporates a semi-automatic transmission which gives on-the-move clutchless gear changes to any of four ratios in each of three forward ranges and one reverse range. This system, developed by David Brown engineers is renowned for simplicity in operation and ease of servicing, and won the Queen's Award for technological achievement in 1974.

Both models incorporate the Selectamatic Hydraulic system, first introduced by David Brown in 1965, and which has proved exceptionally reliable and simple to operate. Here it is served by a fully-live pump driven from the front of the engine crankshaft.

The 4-cylinder diesel engine employs an exhaust driven turbo induction charger to achieve a high horsepower with maximum economy.

Oil immersed disc brakes, operated by a single pedal, provide efficient stopping power on the road or highway. For tight turns at headlands or in the farmyard, two extra separate pedals operate independently, one on each rear wheel.

Whichever model you have chosen to fulfil your particular requirements, it will amply repay the user provided that the simple maintenance routines outlined in this book are carried out regularly.

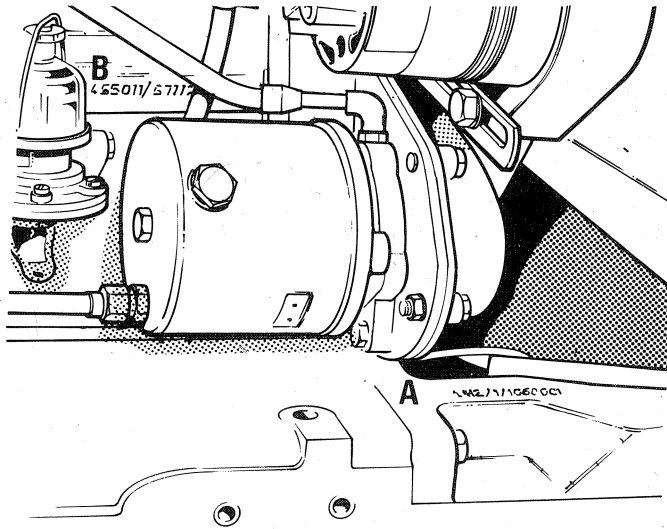

Tractor number/Engine Number/Identification Plate

When ordering parts or with any query always quote the full prefix and serial numbers as follows:

Tractor letters and numbers as stamped on right-hand edge of the chassis front extension at A and on the identification plate, e.g. 1412/1/1050001.

Engine Numbers as stamped on the flat vertical surface on the right-hand side of the cylinder block at B and on the identification plate, e.g. 455011/10001.

Tractor Serial No.....

Engine Serial No.....

Tractor Registration No.....

NOTE — The final drive reduction ratio is stamped in the centre of the rear wheel hub.

Buy Now



Our support email:

ebooklibonline@outlook.com