

DX235LCR

Shop Manual

950106-00081E

Serial Number 5001 and Up

DOOSAN reserves the right to improve our products in a continuing process to provide the best possible product to the market place. These improvements can be implemented at any time with no obligation to change materials on previously sold products. It is recommended that consumers periodically contact their distributors for recent documentation on purchased equipment.

This documentation may include attachments and optional equipment that is not available in your machine's package. Please call your distributor for additional items that you may require.

Illustrations used throughout this manual are used only as a representation of the actual piece of equipment, and may vary from the actual item.

Table of Contents

Safety

Track Excavator Safety.....	SP002112
-----------------------------	----------

Specifications

Specification for DX235LCR.....	SP002113
---------------------------------	----------

General Maintenance

General Maintenance Procedures.....	SP000016
Standard Torques.....	SP000813

Upper Structure

Cabin	SP001938
Counterweight.....	SP002114
Fuel Tank.....	SP002115
Fuel Transfer Pump.....	SP000021
Swing Bearing.....	SP000022

Lower Structure and Chassis

Track Assembly	SP002116
----------------------	----------

Engine and Drive Train

Drive Coupling (Main Pump).....	SP002117
---------------------------------	----------

Hydraulics

Hydraulic System Troubleshooting, Testing and Adjustment	SP002118
Accumulator.....	SP000028
Center Joint (Swivel).....	SP001620
Cylinders.....	SP002119

Swing Device	SP002120
Travel Motor.....	SP001621
Main Pump and PTO	SP000988
Gear Pump	SP000931
Main Control Valve	SP001024
Remote Control Valve (Work Lever / Joystick)	SP000069
Travel Control Valve (with Damper).....	SP002130
Solenoid Valve Assembly	SP001944
Breaker EPPR Valve (Opt)	SP000192
Hydraulic Schematic (DX235LCR)	SP002121

Electrical System

Electrical System	SP002122
Electrical Schematic (DX235LCR).....	SP002123

Attachments

Boom and Arm.....	SP002124
Bucket.....	SP000939

Track Excavator Safety

Edition 1

SAFETY PRECAUTIONS



CAUTION

Follow all safety recommendations and safe shop practices outlined in the front of this manual or those contained within this section.

Always use tools and equipment that are in good working order.

Use lifting and hoisting equipment capable of safely handling load.

Remember, that ultimately safety is your own personal responsibility.

APPLICABLE MODELS

The contents of this section apply to the following models and serial number ranges.

MODEL	SERIAL NUMBER RANGE
DX235LCR	5001 and Up

TO THE OPERATOR OF A DOOSAN EXCAVATOR



Unsafe use of the excavator could lead to serious injury or death. Operating procedures, maintenance and equipment practices or traveling or shipping methods that do not follow the safety guidelines on the following pages could cause serious, potentially fatal injuries or extensive damage to the machine or nearby property.

Please respect the importance of taking responsibility for your own safety, and that of other people who may be affected by your actions.

The safety information on the following pages is organized into the following sections:

1. "Location of Safety Labels" on page 1-10
2. "Summary of Safety Precautions for Lifting in Digging Mode" on page 1-13
3. "Unauthorized Modifications" on page 1-14
4. "General Hazard Information" on page 1-14
5. "Before Starting Engine" on page 1-23
6. "Machine Operation" on page 1-27
7. "Maintenance" on page 1-34
8. "Battery" on page 1-43
9. "Towing" on page 1-45
10. "Shipping and Transportation" on page 1-46
11. "Lifting With Sling" on page 1-46



WARNING

Improper operation and maintenance of this machine can be hazardous and could result in serious injury or death.

Operator and maintenance personnel should read this manual thoroughly before beginning operation or maintenance.

Keep this manual in the storage compartment to the rear of the operator's seat, and have all personnel involved in working on the machine read the manual periodically.

Some actions involved in operation and maintenance of the machine can cause a serious accident, if they are not done in a manner described in this manual.

The procedures and precautions given in this manual apply only to intended uses of the machine.

If you use your machine for any unintended uses that are not specifically prohibited, you must be sure that it is safe for any others. In no event should you or others engage in prohibited uses or actions as described in this manual.

DOOSAN delivers machines that comply with all applicable regulations and standards of the country to which it has been sent. If this machine has been purchased in another country or purchased from someone in another country, it may lack certain safety devices and specifications that are necessary for use in your country. If there is any question about whether your product complies with the applicable standards and regulations of your country, consult DOOSAN or your DOOSAN distributor before operating the machine.



SAFETY ALERT SYMBOL



Be Prepared - Get to Know All Operating and Safety Instructions.

This is the Safety Alert Symbol. Wherever it appears in this manual or on safety signs on the machine you should be alert to the potential for personal injury or accidents. Always observe safety precautions and follow recommended procedures.

Learn the Signal Words Used with the Safety Alert Symbol

The words "CAUTION", "WARNING", and "DANGER" used throughout this manual and on decals on the machine indicate degree of risk of hazards or unsafe practices. All three degrees of risk indicate that safety is involved. Observe precautions indicated whenever you see the Safety Alert "Triangle", no matter which signal word appears next to the "Exclamation Point" symbol.

CAUTION

This word is used on safety messages and safety labels and indicates potential of a hazardous situation that, if not avoided, could result in minor or moderate injury. It may also be used to alert against a generally unsafe practice.

WARNING

This word is used on safety messages and safety labels and indicates potential threat of a hazardous situation that, if not avoided, could result in serious injury or death. It may also be used to alert against highly unsafe practice.

DANGER

This word is used on safety messages and safety labels and indicates an imminent hazard of a situation that, if not avoided, is very likely to cause death or extremely serious injury. It may also be used to alert against equipment that may detonate or explode if handled or treated carelessly.

Safety precautions are described in SAFETY from page -10 on.

DOOSAN cannot predict every circumstance that might involve a potential hazard in operation and maintenance. Therefore the safety messages in this manual and on the machine may not include all possible safety precautions. If any procedures or actions not specifically recommended or allowed in this manual are used, you must be sure that you and others can do such procedures and actions safely and without damaging the machine. If you are unsure about the safety of any procedures, contact a DOOSAN distributor.

GENERAL SAFETY ESSENTIALS

Accessory Applications

The excavator has been primarily designed for moving earth with a bucket. For use as a grapple or for other object handling, contact *DOOSAN* for proper installation and application. Lifting-work applications (unless restricted or prohibited by local regulations) are permitted in approved lift configuration, to rated capacity only, with no side-loading. DO NOT use the machine for activities for which it was not intended. DO NOT use the bucket for lifting work, unless lift slings are used in the approved configuration.

Use of an accessory hydraulic hammer (breaker), work in rough terrain, demolition applications or other hazardous operation may require installation of additional protective structures to safeguard the operator.

Lifting Capacity Rating Configuration

Lifting capacity ratings that are printed at the end of this safety section are based on the machine being level, on a firm supporting surface, with hooks and slings attached in approved configuration. Loads must be balanced and supported evenly. Use tag lines to keep the load steady if wind conditions and large surface area are a problem. Work crew hand signals, individual tasks and safe procedures should all be universally understood before the lift is made.

IMPORTANT

Before using the excavator to make lifts check municipal and regional regulations or statutes that could apply. Governing ordinances may require that all heavy lifting be done with single purpose equipment specifically designed for making lifts, or other local restrictions may apply. Making heavy lifts with a general purpose excavator that can be used for digging, loading, grading or other work may be expressly forbidden by a regional injunction or other legal prohibition. Always follow all of the other instructions, guidelines and restrictions for Safe Lifting in the Operation and Maintenance Manuals.

LOCATION OF SAFETY LABELS

Location of safety labels (decals) can vary from unit to unit. Refer to appropriate Operation and Maintenance Manual, and parts manual for your unit.

Always replace damaged or faded decals.

SAFETY PRECAUTIONS



CAUTION

Follow all safety recommendations and safe shop practices outlined in the front of this manual or those contained within this section.

Always use tools and equipment that are in good working order.

Use lifting and hoisting equipment capable of safely handling the load.

Remember, that ultimately safety is your own responsibility.

APPLICABLE MODELS

The contents of this section apply to the following models and serial number ranges.

MODEL	SERIAL NUMBER RANGE
DX140LCR	5001 and Up
DX235LCR	5001 and Up

REMOVAL

CAUTION

Avoid disassembling cabin if there are strong wind gusts, which could catch large surface area of cabin shell and push it sideways during lift.

1. Park on firm and level ground.
2. Lower front attachment (bucket) to ground.
3. Shut down engine.
4. Set safety lever on "RELEASED" position.
5. Turn starter switch to "I" (ON) position.

WARNING

If engine must be run while performing maintenance, use extreme care. Always have one person in the cabin at all times. Never leave the cabin with the engine running.

6. Fully stroke work levers (joysticks) in all directions to relieve pressure from accumulators.
7. Set safety lever on "LOCK" position.
8. Turn key to "O" (OFF) position and remove from starter switch.
9. Hang maintenance warning tag on controls.
10. Disconnect the battery cable from the negative (-) battery terminal.
11. Prepare cabin shell for removal by disconnecting wiring connectors for:
 - A. Cabin harness - main harness connections.
 - B. Left / right control stand wiring harness connections.
 - C. Air conditioner harness connections and control duct wiring connection.
 - D. Washer hose connections.
 - E. Cabin floor ground.

NOTE: Control stand wiring harnesses and hydraulic piping lines that pass through the floor of the cabin do not need to be disassembled.

NOTE: If unit is equipped with a cabin protective structure (for forestry, or hazardous working conditions), it must be removed.

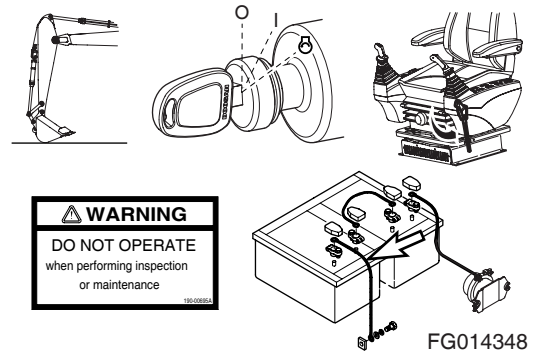

Figure 1

12. Remove floor mat (1, Figure 2).

13. Remove seat (2, Figure 2).

NOTE: Be careful not to damage seat covering.

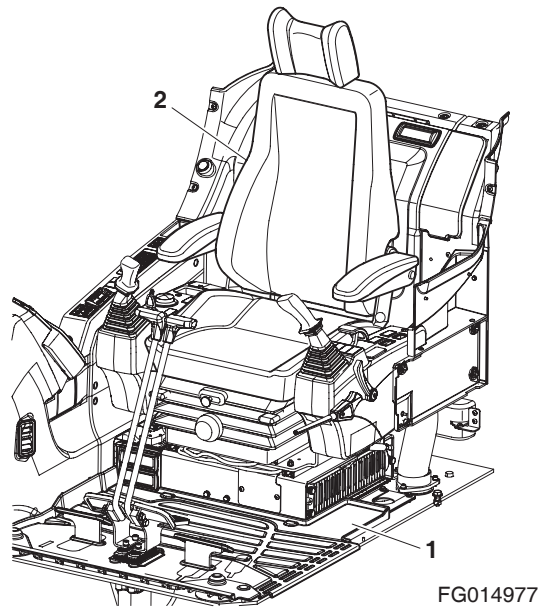

Figure 2

14. Disconnect the cabin main harness connector (1, Figure 3) and remove harness connection mounting bracket from floor.

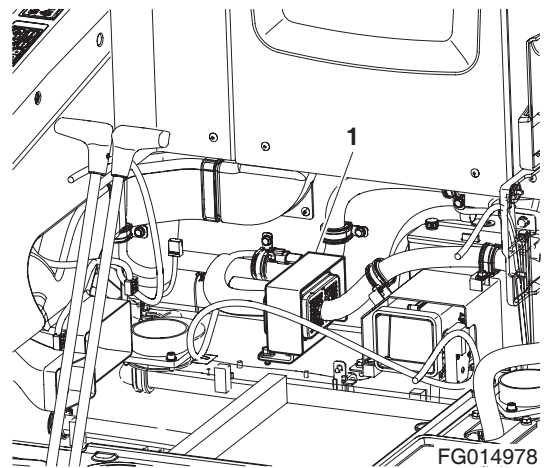

Figure 3

15. Remove joystick hose cover (1 and 2, Figure 4) and disconnect left / right control stand wiring harness connected inside them.

16. Disconnect control duct wiring connectors located on right side and back side of seat.

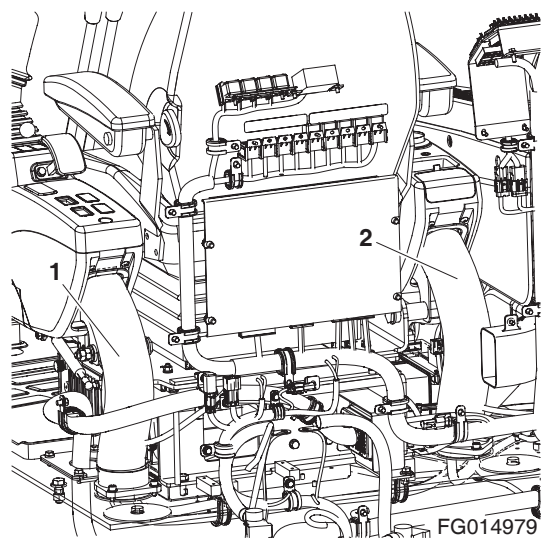

Figure 4

17. Disconnect air conditioner harness connection inside the seat base (1, Figure 5) under seat.

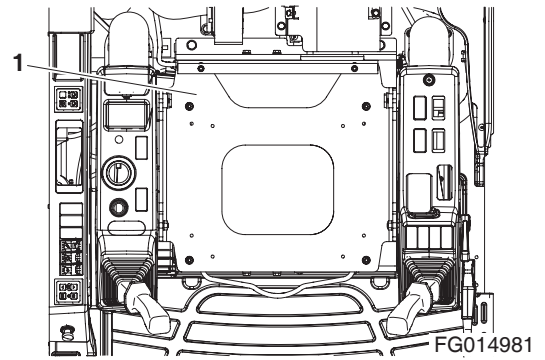

Figure 5

18. Remove air ducts (1 and 2, Figure 6) on right side of cabin from main control duct.

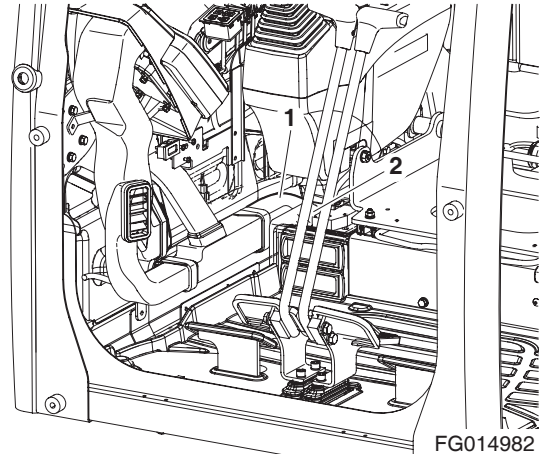

Figure 6

19. Remove rear control duct (1, Figure 7).

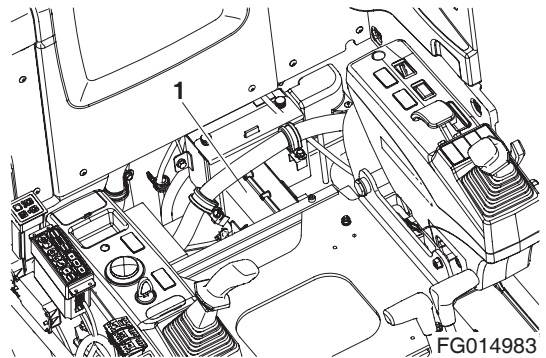

Figure 7

20. Remove washer hose from floor plate.
21. Remove cabin ground.

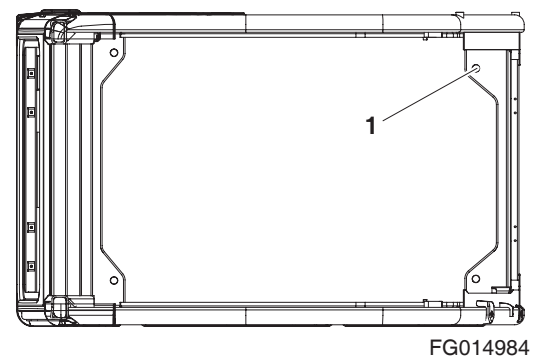

Figure 8

Buy Now



Our support email:

ebooklibonline@outlook.com