

DX340LCA

Shop Manual

950106-00268E

Serial Number 5001 and Up

DOOSAN reserves the right to improve our products in a continuing process to provide the best possible product to the market place. These improvements can be implemented at any time with no obligation to change materials on previously sold products. It is recommended that consumers periodically contact their distributors for recent documentation on purchased equipment.

This documentation may include attachments and optional equipment that is not available in your machine's package. Please call your distributor for additional items that you may require.

Illustrations used throughout this manual are used only as a representation of the actual piece of equipment, and may vary from the actual item.

Table of Contents

Safety

Track Excavator Safety.....	SP002025
-----------------------------	----------

Specifications

Specification for DX340LCA	SP002320
----------------------------------	----------

General Maintenance

General Maintenance Procedures.....	SP000016
Standard Torques.....	SP000813

Upper Structure

Cabin	SP001737
Counterweight.....	SP001738
Fuel Tank.....	SP002321
Fuel Transfer Pump (Opt).....	SP000021
Swing Bearing.....	SP001856
Swing Reduction Gear.....	SP001740

Lower Structure and Chassis

Track Assembly	SP001741
----------------------	----------

Engine and Drive Train

Drive Coupling (Main Pump).....	SP000026
---------------------------------	----------

Hydraulics

Hydraulic System Troubleshooting, Testing and Adjustment	SP002451
Accumulator.....	SP000028
Center Joint (Swivel).....	SP000181
Cylinders.....	SP000030

Swing Motor.....	SP000261
Travel Motor.....	SP000253
Main Pump.....	SP000186
Gear Pump	SP000260
Main Control Valve	SP000034
Remote Control Valve (Work Lever / Joystick)	SP000069
Travel Control Valve (With Damper).....	SP001743
Solenoid Valve Assembly	SP001622
Breaker EPPR Valve (Opt)	SP000192
Hydraulic Schematic DX300LC/DX300LCA/DX340LCA	SP001752

Electrical System

Electrical System	SP002453
Electrical Schematic DX300LCA / DX340LCA	SP002031

Attachments

Boom and Arm.....	SP001851
Bucket.....	SP001852

Track Excavator Safety

Edition 1

SAFETY PRECAUTIONS



CAUTION

Follow all safety recommendations and safe shop practices outlined in the front of this manual or those contained within this section.

Always use tools and equipment that are in good working order.

Use lifting and hoisting equipment capable of safely handling load.

Remember, that ultimately safety is your own personal responsibility.

APPLICABLE MODELS

The contents of this section apply to the following models and serial number ranges.

MODEL	SERIAL NUMBER RANGE
DX300LCA	5001 and Up
DX340LCA	5001 and Up

TO THE OPERATOR OF A DOOSAN EXCAVATOR



Unsafe use of the excavator could lead to serious injury or death. Operating procedures, maintenance and equipment practices or traveling or shipping methods that do not follow the safety guidelines on the following pages could cause serious, potentially fatal injuries or extensive damage to the machine or nearby property.

Please respect the importance of taking responsibility for your own safety, and that of other people who may be affected by your actions.

The safety information on the following pages is organized into the following sections:

1. "General Safety Essentials" on page-9
2. "Location of Safety Labels" on page-10
3. "Summary of Safety Precautions for Lifting in Digging Mode" on page-11
4. "Unauthorized Modifications" on page-12
5. "General Hazard Information" on page-12
6. "Before Starting Engine" on page-21
7. "Machine Operation" on page-24
8. "Maintenance" on page-31
9. "Battery" on page-39
10. "Towing" on page-41
11. "Shipping and Transportation" on page-42
12. "Lifting With Sling" on page-42



WARNING

Improper operation and maintenance of this machine can be hazardous and could result in serious injury or death.

Operator and maintenance personnel should read this manual thoroughly before beginning operation or maintenance.

Keep this manual in the storage compartment to the rear of the operator's seat, and have all personnel involved in working on the machine read the manual periodically.

Some actions involved in operation and maintenance of the machine can cause a serious accident, if they are not done in a manner described in this manual.

The procedures and precautions given in this manual apply only to intended uses of the machine.

If you use your machine for any unintended uses that are not specifically prohibited, you must be sure that it is safe for any others. In no event should you or others engage in prohibited uses or actions as described in this manual.

DOOSAN delivers machines that comply with all applicable regulations and standards of the country to which it has been sent. If this machine has been purchased in another country or purchased from someone in another country, it may lack certain safety devices and specifications that are necessary for use in your country. If there is any question about whether your product complies with the applicable standards and regulations of your country, consult *DOOSAN* or your *DOOSAN* distributor before operating the machine.



SAFETY ALERT SYMBOL



Be Prepared - Get to Know All Operating and Safety Instructions.

This is the Safety Alert Symbol. Wherever it appears in this manual or on safety signs on the machine you should be alert to the potential for personal injury or accidents. Always observe safety precautions and follow recommended procedures.

Learn Signal Words Used with Safety Alert Symbol

The words "CAUTION," "WARNING," and "DANGER" used throughout this manual and on decals on the machine indicate degree of risk of hazards or unsafe practices. All three degrees of risk indicate that safety is involved. Observe precautions indicated whenever you see the Safety Alert "Triangle," no matter which signal word appears next to the "Exclamation Point" symbol.

CAUTION

This word is used on safety messages and safety labels and indicates potential of a hazardous situation that, if not avoided, could result in minor or moderate injury. It may also be used to alert against a generally unsafe practice.

WARNING

This word is used on safety messages and safety labels and indicates potential threat of a hazardous situation that, if not avoided, could result in serious injury or death. It may also be used to alert against highly unsafe practice.

DANGER

This word is used on safety messages and safety labels and indicates an imminent hazard of a situation that, if not avoided, is very likely to cause death or extremely serious injury. It may also be used to alert against equipment that may detonate or explode if handled or treated carelessly.

Safety precautions are described in SAFETY from Operation and Maintenance Manual on page 1-4.

DOOSAN cannot predict every circumstance that might involve a potential hazard in operation and maintenance. Therefore the safety messages in this manual and on the machine may not include all possible safety precautions. If any procedures or actions not specifically recommended or allowed in this manual are used, you must be sure that you and others can do such procedures and actions safely and without damaging the machine. If you are unsure about the safety of any procedures, contact a *DOOSAN* distributor.

GENERAL SAFETY ESSENTIALS

Accessory Applications

The excavator has been primarily designed for moving earth with a bucket. For use as a grapple or for other object handling, contact *DOOSAN* for proper installation and application. Lifting-work applications (unless restricted or prohibited by local regulations) are permitted in approved lift configuration, to rated capacity only, with no side-loading. DO NOT use the machine for activities for which it was not intended. DO NOT use the bucket for lifting work, unless lift slings are used in the approved configuration.

Use of an accessory hydraulic hammer (breaker), work in rough terrain, demolition applications or other hazardous operation may require installation of additional protective structures to safeguard the operator.

Lifting Capacity Rating Configuration

Lifting capacity ratings that are printed at the end of this safety section are based on the machine being level, on a firm supporting surface, with hooks and slings attached in approved configuration. Loads must be balanced and supported evenly. Use tag lines to keep the load steady if wind conditions and large surface area are a problem. Work crew hand signals, individual tasks and safe procedures should all be universally understood before the lift is made.

IMPORTANT

Before using the excavator to make lifts check municipal and regional regulations or statutes that could apply. Governing ordinances may require that all heavy lifting be done with single purpose equipment specifically designed for making lifts, or other local restrictions may apply. Making heavy lifts with a general purpose excavator that can be used for digging, loading, grading or other work may be expressly forbidden by a regional injunction or other legal prohibition. Always follow all of the other instructions, guidelines and restrictions for Safe Lifting in the Operation and Maintenance Manuals.

Swing Reduction Gear

Edition 1

SAFETY PRECAUTIONS



CAUTION

Follow all safety recommendations and safe shop practices outlined in the front of this manual or those contained within this section.

Always use tools and equipment that are in good working order.

Use lifting and hoisting equipment capable of safely handling load.

Remember, that ultimately safety is your own personal responsibility.

APPLICABLE MODELS

The contents of this section apply to the following models and serial number ranges.

MODEL	SERIAL NUMBER RANGE
DX340LC	5980 and Up
DX340LCA	5001 and Up
DX350LC	5980 and Up
DX420LC	5327 and Up

GENERAL DESCRIPTION

Theory of Operation

The swing reduction gearbox is a two-step planetary gearbox with three planet gears, one sun gear and 2-step output reduction. The planetary gear engages with the ring gear. The pinion gear is connected with the output shaft and spline.

The gearbox reduces swing motor rpm to increase swing motor output torque. The available maximum swing speed provides a fast turning rate for efficient, rapid work cycling with more than adequate power for good acceleration.

Parts List

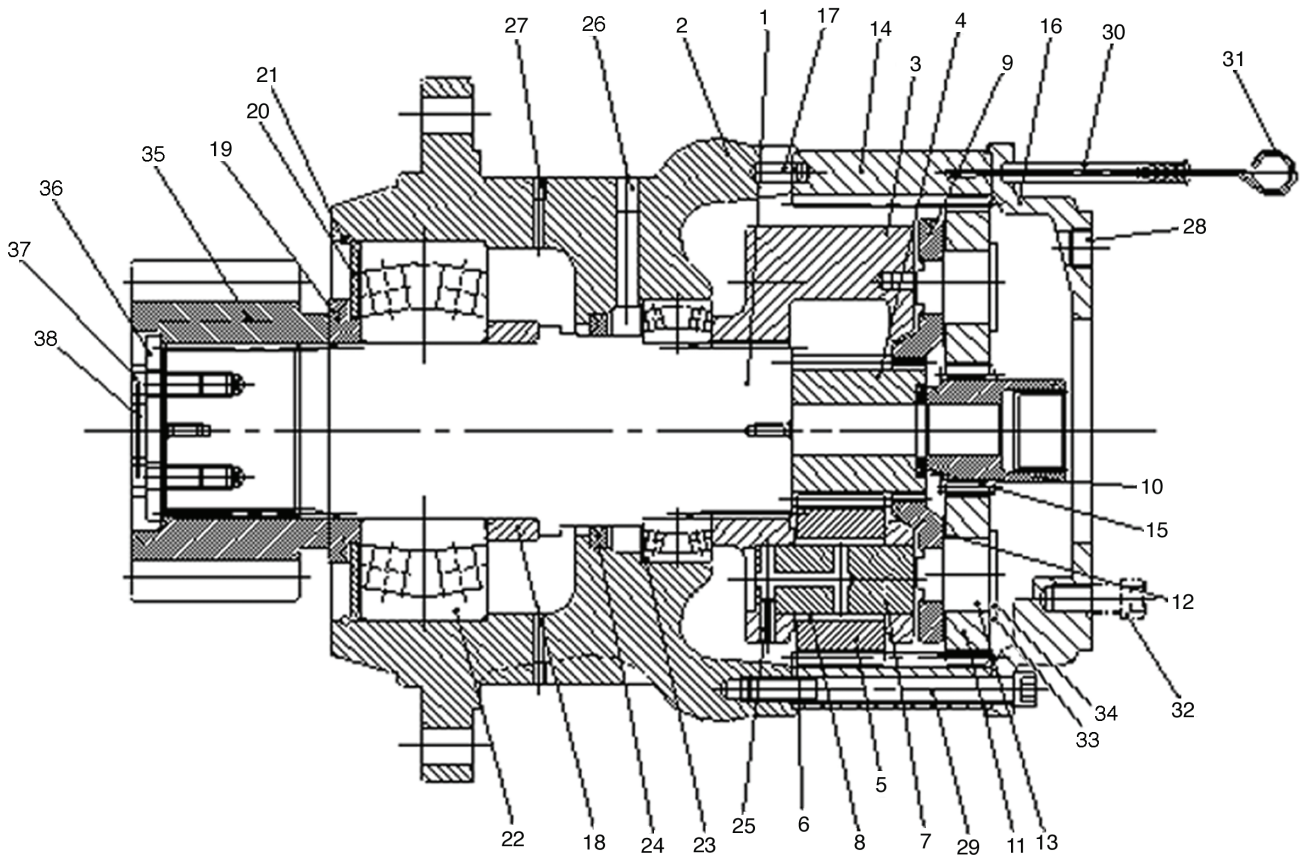

FG004906

Figure 1

REMOVAL

1. Park on firm and level ground.
2. Lower front attachment (bucket) to ground.
3. Shut down engine.
4. Set safety lever on "RELEASED" position.
5. Turn starter switch to "I" (ON) position.



WARNING

If engine must be running while performing maintenance, always use extreme caution. Always have one person in cab at all times. Never leave cab with engine running.

6. Fully stroke work levers (joysticks) in all directions to relieve any pressure from accumulators.
7. Set safety lever on "LOCK" position.
8. Turn key to "O" (OFF) position and remove from starter switch.
9. Hang a maintenance warning tag on controls.
10. Disconnect negative (-) battery cable leading to frame from battery.
11. Tag and disconnect hoses from swing motor (1, Figure 3). Plug and cap hoses and ports to prevent contamination from entering hydraulic system or component.
12. Disconnect tube (2) from drain cock (3) and hose fitting (7) from fill hole.
13. Remove twelve bolts and washers (4, Figure 3) holding swing reduction gearbox (5) to frame.
14. Using a suitable lifting device, sling swing motor (1, Figure 3) and remove swing motor and reduction gearbox (5) as an assembly from unit.

NOTE: A drain cock (3, Figure 3) and tube are on side of gearbox. Be careful not to damage valve or tube.

NOTE: There are two alignment pins (6, Figure 3), one on each side of reduction gearbox flange.

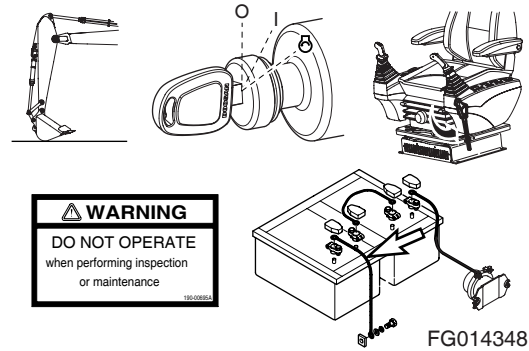

Figure 2

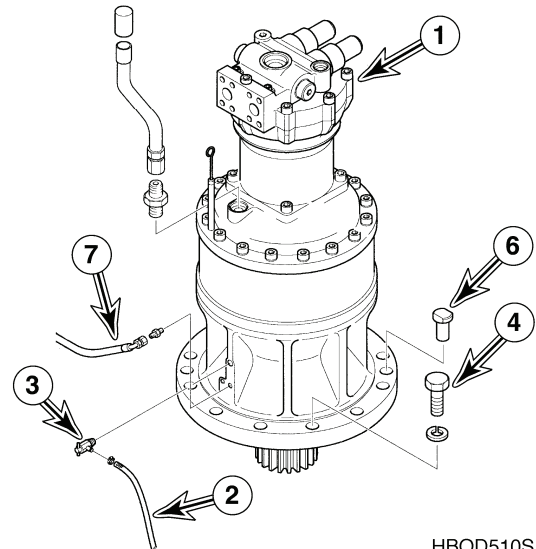

Figure 3

DISASSEMBLY

NOTE: *Clean all exterior surfaces of the gearbox before beginning disassembly.*

1. Remove the drain plugs and allow all oil to drain from the gearbox.

IMPORTANT

Use a clean, dry container (with at least 11 liters, or 2.9 gallons capacity) to catch gear oil. A clean container allows an evaluation to be made of the used oil. The presence or relative lack of metal wear shavings in the used oil or obvious deterioration or contamination of the oil can provide a useful indicator of the motor's general condition.

2. Remove the socket cap screws that hold the cover to the gearbox housing. Remove the cover from the housing.
3. Remove the sun gear.
4. Thread an eye bolt into each of the three shafts that support the 1st level planetary gears. Loop lifting straps through the eye bolts and lift the planetary gears and the first planetary mounting plate out of the gearbox.
5. Slide sun gear off the shaft and out of the gearbox.

6. Thread an eye bolt into each of the three shafts that support the planetary gears. Loop lifting straps through the eye bolts and lift the gear housing assembly out of the gearbox.

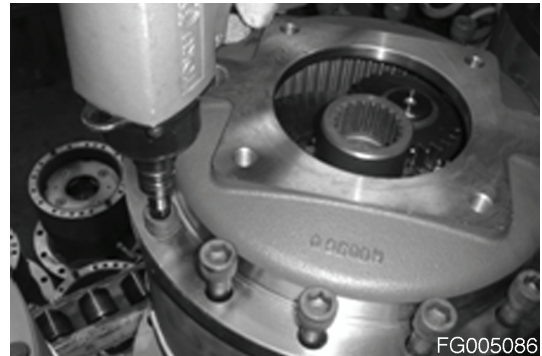

Figure 4

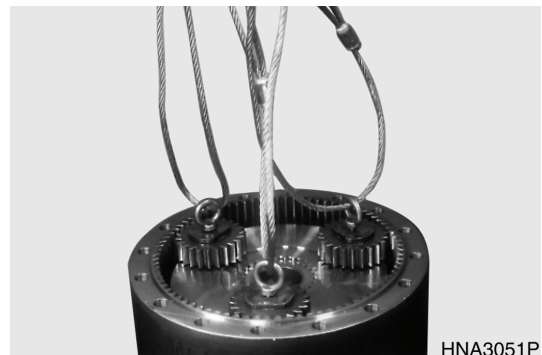

Figure 5

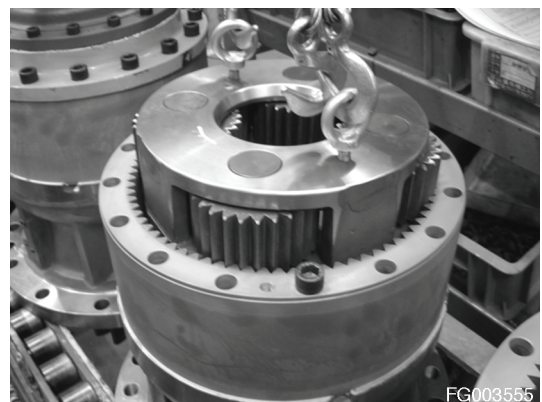

Figure 6

Buy Now



Our support email:

ebooklibonline@outlook.com