



Shop Manual

DX225LC-3 Excavator

Serial Number 1001 and Up
Serial Number 50001 and Up (Europe Only)

DOOSAN and the DOOSAN logo are registered trademarks of DOOSAN Corporation in the United States and various other countries around the world.



950106-00364E

March 2012

Table of Contents

Safety

Track Excavator Maintenance Safety	SP002322
--	----------

Specifications

Specifications for DX225LC-3.....	SP002491
-----------------------------------	----------

General Maintenance

General Maintenance Instructions.....	SP002454
Standard Torques.....	SP002404

Upper Structure

Cabin	SP002324
Counterweight.....	SP002492
Fuel Tank.....	SP002493
Fuel Transfer Pump (Option)	SP002534
Swing Bearing.....	SP002329

Lower Structure and Chassis

Track Assembly	SP002494
----------------------	----------

Engine and Drivetrain

Engine Coolant Heater (Option)	SP002328
Drive Coupling (Main Pump).....	SP002495

Hydraulics

Hydraulic System Troubleshooting, Testing and Adjustment	SP002535
Accumulator.....	SP002455
Center Joint (Swivel).....	SP002456
Cylinders.....	SP002497

Swing Device	SP002498
Travel Device.....	SP002499
Main Pump.....	SP002502
PTO Server.....	SP002503
Gear Pump	SP002500
Main Control Valve	SP002403
Remote Control Valve (Work Lever / Joystick)	SP002395
Travel Control Valve (with Damper).....	SP002381
Solenoid Valve Assembly	SP002406
Breaker EPPR Valve (Option)	SP002458
Dozer Valve	SP002529
Hydraulic Schematic (DX225LC-3).....	SP002507

Electrical System

Electrical System	SP002337
Electrical Schematic	SP002508

Attachments

Boom and Arm.....	SP002505
Bucket.....	SP002506

Track Excavator Maintenance Safety

Edition 2

SAFETY INSTRUCTIONS



WARNING

AVOID DEATH OR SERIOUS INJURY

Instructions are necessary before operating or servicing machine. Read and understand the Operation and Maintenance Manual and signs (decals) on machine. Follow warnings and instructions in the manuals when making repairs, adjustments or servicing. Check for correct function after adjustments repairs or service. Untrained operators and failure to follow instructions can cause death or serious injury.

APPLICABLE MODELS

The contents of this section apply to the following models and serial number ranges.

MODEL	SERIAL NUMBER RANGE
DX140LC-3	1001 and Up, 50001 and Up
DX180LC-3	1001 and Up, 50001 and Up
DX225LC-3	1001 and Up, 50001 and Up
DX255LC-3	1001 and Up, 50001 and Up
DX300LC-3	1001 and Up, 50001 and Up
DX340LC-3	1001 and Up, 10001 and Up
DX350LC-3	1001 and Up, 10001 and Up
DX380LC-3	10001 and Up
DX420LC-3	10001 and Up
DX490LC-3	10001 and Up
DX530LC-3	10001 and Up

SAFETY MESSAGES

Safety messages and safety decals included in this manual and on the machine provide instructions how to operate, service and maintain the machine. Safety messages and safety decals indicate potential hazards and describe safety precautions required to avoid hazards. Operator and maintenance personnel should read and understand these safety messages and decals before beginning operation or maintenance.

SAFETY ALERT SYMBOL

Be Prepared - Get to Know All Operating and Safety Instructions.

This is a Safety Alert Symbol. Wherever it appears in this manual or on safety decals on the machine, you should be alert to the potential for personal injury or accidents.

Always observe safety precautions and follow recommended procedures.

Signal Words

The signal words "DANGER", "WARNING", "CAUTION" are used throughout safety messages and safety decals in this manual or on the machine. They indicate an existence of, and the relative seriousness of, a hazard. All three indicate that a safety risk is involved. Observe the precautions indicated whenever a Safety Alert Symbol is present, no matter which signal word appears next to it.

DANGER

DANGER - This signal word is used on safety messages and safety labels and indicates an imminently hazardous situation which, if not avoided, will result in death or serious injury.

WARNING

WARNING - This signal word is used on safety messages and safety labels and indicates a potentially hazardous situation which, if not avoided, could result in death or serious injury.

CAUTION

CAUTION - This signal word is used on safety messages and safety labels and indicates a potentially hazardous situation which, if not avoided, could result in minor or moderate injury.

SAFETY DECALS

Location of safety labels (decals) can vary from unit to unit.

Refer to appropriate Operation and Maintenance Manual, and parts manual for your unit.

Always replace damaged or faded decals.

GENERAL

Safe Operation is Operator's Responsibility

Only trained and authorized personnel should operate and maintain the machine.

Follow all safety rules, regulations and instructions when operating or performing maintenance on machine.

- Do not operate machine if you are under the influence of drugs or alcohol. An operator who is taking prescription drugs must get medical advice to determine if he or she can safely operate a machine.
- When working with other personnel on a worksite, be sure that all personnel know nature of work and understand all hand signals that are to be used.
- Be sure that all guards and shields are installed in their proper location. Have guards and shields repaired or replaced immediately if damaged.
- Be sure that you understand the use and maintenance of all safety features such as safety lock lever and seat belt. Use them properly.
- Never remove, modify or disable any safety features. Always keep them in good operating condition.
- Always check for and know the location of underground and overhead utility lines before excavating.
- Failure to use and maintain safety features according to instructions in this manual, Safety Manual and Shop Manual can result in death or serious injury.

Know Your Machine

Know how to operate your machine. Know the purpose of all controls, gauges, signals, indicators and monitor displays. Know the rated load capacity, speed range, braking and steering characteristics, turning radius and operating clearances. Keep in mind that rain, snow, ice, loose gravel, soft ground, slopes etc., can change operating capabilities of your machine.

Proper Work Tools and Attachments

Only use work tools and attachments that are recommended by DOOSAN for use on DOOSAN machines. When installing and using optional attachments, read instruction manual for attachment, and general information related to attachments in this manual. Because DOOSAN cannot anticipate, identify or test all attachments that owners may want to install on their machines, contact DOOSAN for written authorization and approval of attachments, and their compatibility with optional kits.

Attachments and attachment control systems that are compatible with the machine are required for safe and reliable machine operation. Do not exceed maximum operating weight (machine weight plus attachment) that is listed on ROPS certification plate.

Make sure that all guards and shields are in place on machine and on work tool. Depending on type or combination of work equipment, there is a potential that work equipment could interfere with the cabin or other parts of machine. Before using unfamiliar work equipment, check if there is any potential of interference, and operate with caution.

While you are performing any maintenance, testing, or adjustments to attachments, stay clear of the following areas: cutting edges, pinch points, and crushing surfaces.

Never use attachment as a work platform or manlift.

Contact your DOOSAN distributor about auxiliary hydraulic kits for attachments installation. If you are in doubt about compatibility of a particular attachment with a machine, consult your DOOSAN distributor.

Pressurized Fluids

Pressurized air or fluids can cause debris and/or fluids to be blown out. This could result in death or serious injury.

Immediately after operations are stopped, coolant, engine oil, and hydraulic oil are at their highest temperatures and the radiator and hydraulic tank are still under pressure. Always wait for temperature to cool down. Follow specified procedures when attempting to remove caps, drain oil or coolant, or replacing filters. Always wait for temperature to cool down, and follow specified procedures when performing these operations. Failure to do so can result in death or serious injury.

When pressurized air and/or pressurized water is used for cleaning, wear protective clothing, protective shoes, and eye protection. Eye protection includes goggles or a protective face shield.

Pressure can be trapped in a hydraulic system and should be relieved before maintenance is started.

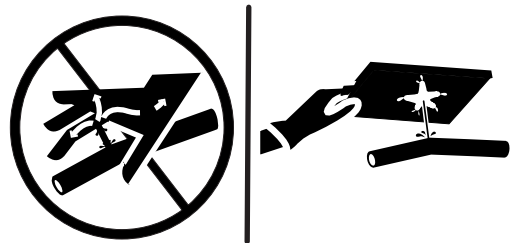

FG018457

Figure 1

Releasing trapped pressure can cause sudden machine movement or attachment movement. Use caution if you disconnect hydraulic lines or fittings.

High-pressure oil that is released can cause a hose to whip or oil to spray. Fluid penetration can result in death or serious injury. If fluid enters skin or eyes, get immediate medical attention from a physician familiar with this injury.

Obey all local laws and regulations for disposal of liquids.

To prevent hot coolant from spraying out, stop engine and wait for coolant to cool. Using gloves, slowly loosen cap to relieve pressure.

Flying or Falling Objects

On work sites where there is a potential hazard that flying or falling objects can hit operator's cabin, select and use a guard to match operating conditions for additional operator protection.

Working in mines, tunnels, deep pits, and loose or wet surfaces, could produce hazard of falling rocks or flying objects. Additional protection for operator's cabin could be required such as an Operator Protection Guard (OPG) or window guards. Contact your DOOSAN distributor for information on available protective guards.

To prevent personnel from being struck by flying objects, keep personnel out of work area.

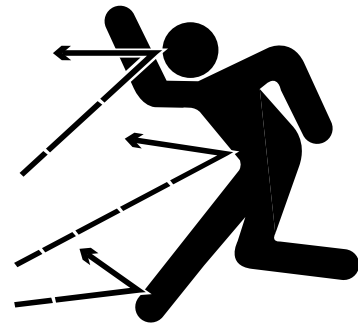

HAOA110L

Figure 2



HAOA100L

Figure 3

Swing Bearing

Edition 2

SAFETY INSTRUCTIONS



WARNING

AVOID DEATH OR SERIOUS INJURY

Instructions are necessary before operating or servicing machine. Read and understand the Operation and Maintenance Manual and signs (decals) on machine. Follow warnings and instructions in the manuals when making repairs, adjustments or servicing. Check for correct function after adjustments repairs or service. Untrained operators and failure to follow instructions can cause death or serious injury.

APPLICABLE MODELS

The contents of this section apply to the following models and serial number ranges.

MODEL	SERIAL NUMBER RANGE
DX140LC-3	1001 and Up, 50001 and Up
DX180LC-3	1001 and Up, 50001 and Up
DX225LC-3	1001 and Up, 50001 and Up
DX255LC-3	1001 and Up, 50001 and Up
DX300LC-3	1001 and Up, 50001 and Up
DX340LC-3	1001 and Up, 10001 and Up
DX350LC-3	1001 and Up, 10001 and Up
DX380LC-3	10001 and Up
DX420LC-3	10001 and Up
DX490LC-3	10001 and Up
DX530LC-3	10001 and Up

SWING BEARING MAINTENANCE

Operating Recommendation

The service life of the swing bearing may be extended if a daily effort is made to equalize usage over both ends of the excavator. If the excavator is used in the same operating configuration day in and day out (for example, with the travel motors always under the counterweight, or with the attachment over one side of the machine more than the other), the bearing's service life could be reduced. Repositioning the excavator during the work shift, to work the opposite end of the bearing, will provide a more even and gradual rate of wear and extended service life.

Measuring Swing Bearing Axial Play

Regular checks of bearing displacement should be made at least twice a year. Use a dial indicator. Push the attachment against the ground to lift up the excavator above the ground and take measurements at 4 points, 90° apart, around the circumference of the bearing (Figure 1).

Record and keep all measurements. Play in the bearing should increase minimally from one inspection to the next. Eventually, however, as the bearing begins to approach the limit of its service life, clearance increases become much more pronounced and the actual measured play in the bearing could exceed twice the value that was measured when the machine was new.

Measuring Bearing Lateral Play

When vertical checks are made, the side to side play in the bearing can be checked by fully retracting the arm and bucket cylinders and extending the tip of the bucket as far forward as it will go. With the excavator parked on a flat, level surface and the bucket tip just off the ground, push against the bucket sideways to take up all the lateral clearance in the bearing. (Less than 100 lb of force should be required to move the bucket over all the way.) Check lateral play in both directions and record the values. When the bearing is beginning to approach the end of its service life, measured lateral clearance should start to show increase in value.

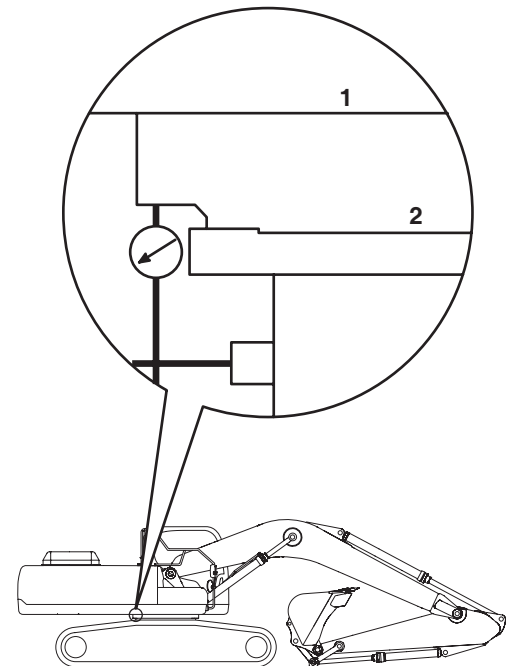

FG018734

Figure 1

Swing Bearing Basic Operation

The swing bearing, which connects the upper structure with the lower structure, consists of a inner ring, outer ring and ball bearings. During swing movement, power from the swing motor is transferred to the pinion by planetary gears connected to gears on the inner ring, which is fixed in the undercarriage. Ball bearings turn the outer ring.

Reference Number	Description
1	Outer Ring
2	Inner Ring
3	Tapered Pin
4	Plug
5	Ball
6	Retainer
7	Seal

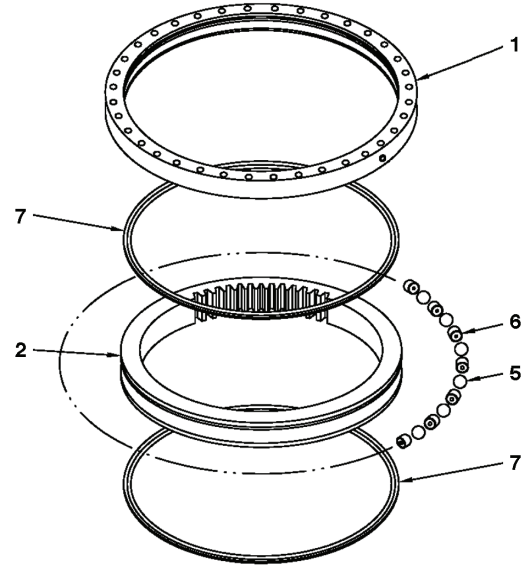

FG003909

Figure 2

Disassembly

1. Remove tip of tapered pin (3, Figure 3) using grinder and tap lightly to remove debris.

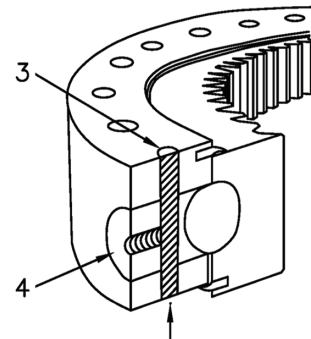

FG003884

Figure 3

2. Remove plug (4, Figure 4) using a M10 x P 1.5 bolt.

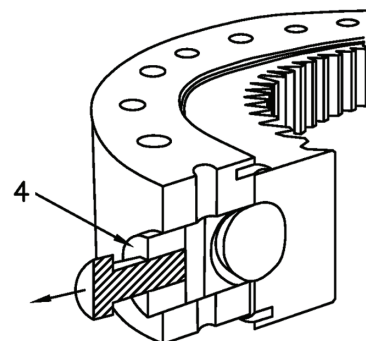

FG003885

Figure 4

Buy Now



Our support email:

ebooklibonline@outlook.com