



Shop Manual

DX255LC-3 Excavator

Serial Number 1001 and Up
Serial Number 50001 and Up (Europe Only)

DOOSAN and the DOOSAN logo are registered trademarks of DOOSAN Corporation in the United States and various other countries around the world.



950106-00374E

April 2012

Table of Contents

Safety

Track Excavator Maintenance Safety	SP002322
--	----------

Specifications

Specifications for DX255LC-3.....	SP002547
-----------------------------------	----------

General Maintenance

General Maintenance Instructions.....	SP002454
Standard Torques.....	SP002404

Upper Structure

Cabin	SP002324
Counterweight.....	SP002548
Fuel Tank.....	SP002549
Fuel Transfer Pump (Option)	SP002550
Swing Bearing.....	SP002329

Lower Structure and Chassis

Track Assembly	SP002551
----------------------	----------

Engine and Drivetrain

Engine Coolant Heater (Option)	SP002328
Drive Coupling (Main Pump).....	SP002586

Hydraulics

Hydraulic System Troubleshooting, Testing and Adjustment	SP002597
Accumulator.....	SP002455
Center Joint (Swivel).....	SP002456
Cylinders.....	SP002587

Swing Device	SP002588
Travel Device.....	SP002590
Main Pump.....	SP002591
Gear Pump	SP002500
Main Control Valve	SP002403
Remote Control Valve (Work Lever / Joystick)	SP002395
Travel Control Valve (with Damper).....	SP002381
Solenoid Valve Assembly	SP002406
Breaker EPPR Valve (Option)	SP002458
Hydraulic Schematic (DX255LC-3).....	SP002589

Electrical System

Electrical System	SP002337
Electrical Schematic	SP002508

Attachments

Boom and Arm.....	SP002592
Bucket.....	SP002506

Track Excavator Maintenance Safety

Edition 3

SAFETY INSTRUCTIONS



WARNING

AVOID DEATH OR SERIOUS INJURY

Instructions are necessary before operating or servicing machine. Read and understand the Operation and Maintenance Manual and signs (decals) on machine. Follow warnings and instructions in the manuals when making repairs, adjustments or servicing. Check for correct function after adjustments repairs or service. Untrained operators and failure to follow instructions can cause death or serious injury.

APPLICABLE MODELS

The contents of this section apply to the following models and serial number ranges.

MODEL	SERIAL NUMBER RANGE
DX140LC-3	1001 and Up, 50001 and Up
DX180LC-3	1001 and Up, 50001 and Up
DX225LC-3	1001 and Up, 50001 and Up
DX255LC-3	1001 and Up, 50001 and Up
DX300LC-3	1001 and Up, 50001 and Up
DX340LC-3	1001 and Up, 10001 and Up
DX350LC-3	1001 and Up, 10001 and Up
DX380LC-3	10001 and Up
DX420LC-3	10001 and Up
DX490LC-3	10001 and Up
DX530LC-3	10001 and Up

SAFETY MESSAGES

Safety messages and safety decals included in this manual and on the machine provide instructions how to operate, service and maintain the machine. Safety messages and safety decals indicate potential hazards and describe safety precautions required to avoid hazards. Operator and maintenance personnel should read and understand these safety messages and decals before beginning operation or maintenance.

SAFETY ALERT SYMBOL

Be Prepared - Get to Know All Operating and Safety Instructions.

This is a Safety Alert Symbol. Wherever it appears in this manual or on safety decals on the machine, you must be alert to the potential for personal injury or accidents.

Always observe safety precautions and follow recommended procedures.

Signal Words

The signal words "DANGER", "WARNING", "CAUTION" are used throughout safety messages and safety decals in this manual or on the machine. They indicate an existence of, and the relative seriousness of, a hazard. All three indicate that a safety risk is involved. Observe the precautions indicated whenever a Safety Alert Symbol is present, no matter which signal word appears next to it.

DANGER

DANGER - This signal word is used on safety messages and safety labels and indicates an imminently hazardous situation which, if not avoided, will result in death or serious injury.

WARNING

WARNING - This signal word is used on safety messages and safety labels and indicates a potentially hazardous situation which, if not avoided, could result in death or serious injury.



CAUTION

CAUTION - This signal word is used on safety messages and safety labels and indicates a potentially hazardous situation which, if not avoided, could result in minor or moderate injury.

Other Signal Words

In addition to safety signal words, the following signal words are used to indicate proper and effective use of machine.

IMPORTANT

This signal word identifies procedures which must be followed to avoid damage to machine.

The word "NOTE" identifies information for effective use.

SAFETY DECALS

Location of safety labels (decals) can vary from unit to unit.

Refer to appropriate Operation and Maintenance Manual, and parts manual for your unit.

Always replace damaged or faded decals.

GENERAL

Safe Operation is Operator's Responsibility

Only trained and authorized personnel should operate and maintain the machine.

Follow all safety rules, regulations and instructions when operating or performing maintenance on machine.

- Do not operate machine if you are under the influence of drugs or alcohol. An operator who is taking prescription drugs must get medical advice to determine if he or she can safely operate a machine.
- When working with other personnel on a work site, be sure that all personnel know nature of work and understand all hand signals that are to be used.
- Be sure that all guards and shields are installed in their proper location. Have guards and shields repaired or replaced immediately if damaged.
- Be sure that you understand the use and maintenance of all safety features such as safety lock lever and seat belt. Use them properly.
- Never remove, modify or disable any safety features. Always keep them in good operating condition.
- Always check for and know the location of underground and overhead utility lines before excavating.
- Failure to use and maintain safety features according to instructions in this manual, Safety Manual and Shop Manual can result in death or serious injury.

Know Your Machine

Know how to operate your machine. Know the purpose of all controls, gauges, signals, indicators and monitor displays. Know the rated load capacity, speed range, braking and steering characteristics, turning radius and operating clearances. Keep in mind that rain, snow, ice, loose gravel, soft ground, slopes etc., can change operating capabilities of your machine.

Proper Work Tools and Attachments

Only use work tools and attachments that are recommended by DOOSAN for use on DOOSAN machines. When installing and using optional attachments, read instruction manual for attachment, and general information related to attachments in this manual. Because DOOSAN cannot anticipate, identify or test all attachments that owners may want to install on their machines, contact DOOSAN for written authorization and

approval of attachments, and their compatibility with optional kits.

Attachments and attachment control systems that are compatible with the machine are required for safe and reliable machine operation. Do not exceed maximum operating weight (machine weight plus attachment) that is listed on ROPS certification plate.

Make sure that all guards and shields are in place on machine and on work tool. Depending on type or combination of work equipment, there is a potential that work equipment could interfere with the cabin or other parts of machine. Before using unfamiliar work equipment, check if there is any potential of interference, and operate with caution.

While you are performing any maintenance, testing, or adjustments to attachments, stay clear of the following areas: cutting edges, pinch points, and crushing surfaces.

Never use attachment as a work platform or manlift.

Contact your DOOSAN distributor about auxiliary hydraulic kits for attachments installation. If you are in doubt about compatibility of a particular attachment with a machine, consult your DOOSAN distributor.

Pressurized Fluids

Pressurized air or fluids can cause debris and/or fluids to be blown out. This could result in death or serious injury.

Immediately after operations are stopped, coolant, engine oil, and hydraulic oil are at their highest temperatures and the radiator and hydraulic tank are still under pressure. Always wait for temperature to cool down. Follow specified procedures when attempting to remove caps, drain oil or coolant, or replacing filters. Always wait for temperature to cool down, and follow specified procedures when performing these operations. Failure to do so can result in death or serious injury.

When pressurized air and/or pressurized water is used for cleaning, wear protective clothing, protective shoes, and eye protection. Eye protection includes goggles or a protective face shield.

Pressure can be trapped in a hydraulic system and must be relieved before maintenance is started.

Releasing trapped pressure can cause sudden machine movement or attachment movement. Use caution if you disconnect hydraulic lines or fittings.

High-pressure oil that is released can cause a hose to whip or oil to spray. Fluid penetration can result in death or serious injury. If fluid enters skin or eyes, get immediate medical attention from a physician familiar with this injury.

Obey all local laws and regulations for disposal of liquids.

To prevent hot coolant from spraying out, stop engine and wait for coolant to cool. Using gloves, slowly loosen cap to relieve pressure.

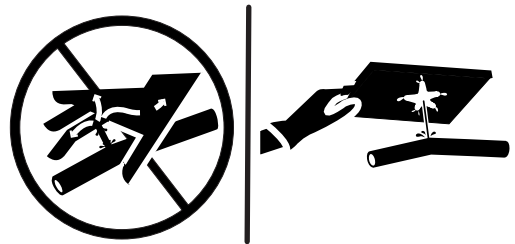

FG018457

Figure 1

Track Assembly

Edition 1

SAFETY INSTRUCTIONS



WARNING

AVOID DEATH OR SERIOUS INJURY

Instructions are necessary before operating or servicing machine. Read and understand the Operation and Maintenance Manual and signs (decals) on machine. Follow warnings and instructions in the manuals when making repairs, adjustments or servicing. Check for correct function after adjustments repairs or service. Untrained operators and failure to follow instructions can cause death or serious injury.

APPLICABLE MODELS

The contents of this section apply to the following models and serial number ranges.

MODEL	SERIAL NUMBER RANGE
DX255LC-3	1001 and Up, 50001 and Up

GENERAL DESCRIPTION

The track assembly is composed of the following major components:

1. Track
2. Front Idler Roller
3. Upper Roller
4. Lower Roller
5. Track Spring and Track Adjustment Cylinder

TRACK TENSION



AVOID DEATH OR SERIOUS INJURY

Measuring track tension requires two people. One person must be in the operator's seat, operating the controls while the other person makes dimensional checks. Block frame to make sure the machine won't move or shift position during service. Warm up the engine to prevent stalls, park the excavator in an area that provides level, uniform ground support and/or use support blocks when necessary.

The track adjusting mechanism is under very high-pressure. NEVER release grease pressure too fast. The track tension grease valve should never be loosened more than one (1) complete turn from the fully tightened down position. Bleed off grease pressure slowly. Keep your body away from the valve always. Always wear eye and face protection when adjusting track tension.

Track shoe link pins and bushings wear with normal usage, reducing track tension. Periodic adjustment is necessary to compensate for wear and it may also be required by working conditions.

1. Track tension is checked by jacking up one side of the excavator. See Figure 1. Place blocking under frame while taking measurement.

Turn the track backward by 1 - 2 turns.

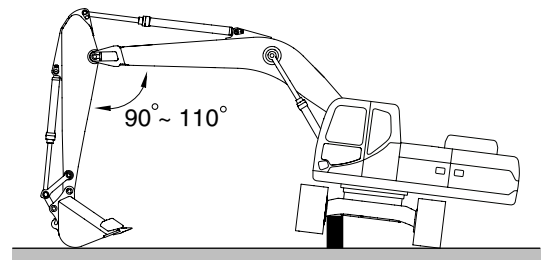

FG018383

Figure 1

2. Measuring the distance (A, Figure 2) between the bottom of the side frame and the top of the lowest crawler shoe. Recommended tension for operation over most types of terrain is distance "B" in below table.

NOTE: Clean off the tracks before checking clearance for accurate measurements.

3. Too little sag in the crawler track (less than clearance distance "B" in below table) can cause excessive component wear. The recommended adjustment can also be too tight causing accelerated stress and wear if ground conditions are wet, marshy or muddy.

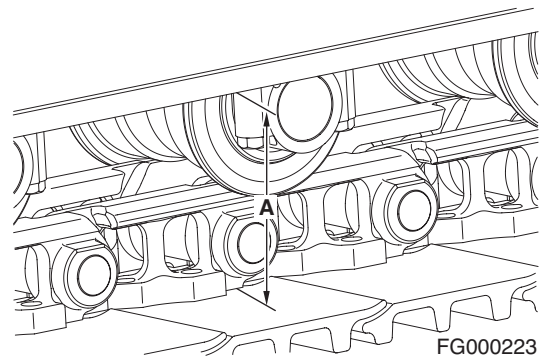

FG000223

Figure 2

4. The increased clearance recommended for muddy, sandy or snowy ground conditions is between distance "C" in the below table.

Terrain Type	Recommended Distance "A"
Normal "B"	320 - 340 mm (12.60 - 13.39 in)
Muddy, Sandy or Snowy "C"	340 - 370 mm (13.39 - 14.57 in)



WARNING

AVOID DEATH OR SERIOUS INJURY

The track adjusting mechanism is under very high-pressure. **NEVER** release grease pressure too fast. The track tension grease valve should never be loosened more than one (1) complete turn from the fully tightened down position. Bleed off grease pressure slowly. Keep your body away from the valve always. Always wear eye and face protection when adjusting track tension.

5. Track tension adjustments are made through the grease fitting (1, Figure 3) in the middle of each side frame. Adding grease increases the length of an adjustment cylinder (2). Extending the adjustment cylinder, increases the pressure on the tension spring pushing the track idler wheel outward.
6. If there is not enough slack or clearance in the tracks and the adjustment is too tight, the idler wheel and adjusting cylinder can be retracted by bleeding off grease through hole in adjustment cylinder (2, Figure 3).

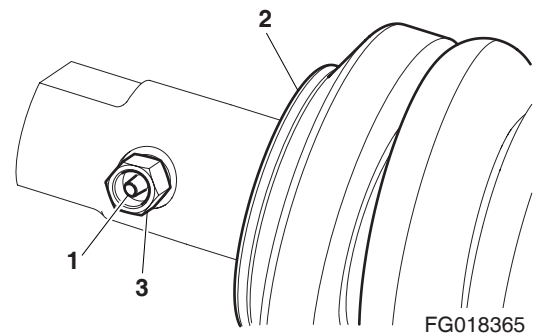

Figure 3

Buy Now



Our support email:

ebooklibonline@outlook.com