



---

# Shop Manual

# DX235NLC-5 Excavator

---

Serial Number **1001 and Up**

DOOSAN and the DOOSAN logo are registered trademarks of DOOSAN Corporation in the United States and various other countries around the world.



950106-01115E

January 2015

# Table of Contents

<b>1 Safety</b>	1 Track Excavator Maintenance Safety
<b>2 Specifications</b>	1 Specifications
<b>3 General Maintenance</b>	1 General Maintenance Instructions 2 Standard Torques
<b>4 Engine</b>	1 Engine
<b>5 Upper Structure</b>	1 Cabin 2 Counterweight 3 Hydraulic Oil Tank 4 Fuel Tank 5 Main Pump 6 Drive Coupling (Main Pump) 7 Main Control Valve 8 Swing Device 9 Joystick Valve (Work Lever) 10 Travel Control Valve (with Damper) 11 Solenoid Valve 12 EPPR Valve (One or Two-way) 13 Accumulator 14 Gear Pump (Rotating) 15 One Spool Valve (Rotating)

<b>6 Lower Structure and Chassis</b>	1 Swing Bearing
	2 Center Joint
	3 Travel Device
	4 Track Assembly
<b>7 Front</b>	1 Boom and Arm
	2 Bucket
	3 Cylinders
<b>8 Hydraulic System</b>	1 Hydraulic System
	2 Hydraulic System Testing and Adjustment
	3 Hydraulic System Troubleshooting
<b>9 Electrical System</b>	1 Electrical System
<b>10 Options</b>	1 One Way
	2 Two-way
	3 Rotating
	4 Quick Coupler
	5 Two Pump
<b>11 Schematic</b>	1 Hydraulic Schematic/Electrical Schematic

# **Track Excavator Maintenance Safety**

**Edition 1**

# SAFETY INSTRUCTIONS

---



## WARNING

---

### AVOID DEATH OR SERIOUS INJURY

Instructions are necessary before operating or servicing machine. Read and understand the Operation & Maintenance Manual and signs (decals) on machine. Follow warnings and instructions in the manuals when making repairs, adjustments or servicing. Check for correct function after adjustments repairs or service. Untrained operators and failure to follow instructions can cause death or serious injury.

---

## SAFETY MESSAGES

Replace with Safety Messages Section on pages III and IV in the Doosan Operation & Maintenance Manual.

# GENERAL

## Safe Operation is Operator's Responsibility

Only trained and authorized personnel should operate and maintain the machine.

Follow all safety rules, regulations and instructions when operating or performing maintenance on machine.

- Do not operate machine if you are under the influence of drugs or alcohol. An operator who is taking prescription drugs must get medical advice to determine if he or she can safely operate a machine.
- When working with other personnel on a work site, be sure that all personnel know nature of work and understand all hand signals that are to be used.
- Be sure that all guards and shields are installed in their proper location. Have guards and shields repaired or replaced immediately if damaged.
- Be sure that you understand the use and maintenance of all safety features such as safety lever and seat belt. Use them properly.
- Never remove, modify or disable any safety features. Always keep them in good operating condition.
- Always check for and know the location of underground and overhead utility lines before excavating.
- Failure to use and maintain safety features according to instructions in this manual, Safety Manual and Shop Manual can result in death or serious injury.

## Know Your Machine

Know how to operate your machine. Know the purpose of all controls, gauges, signals, indicators and monitor displays. Know the rated load capacity, speed range, braking and steering characteristics, turning radius and operating clearances. Keep in mind that rain, snow, ice, loose gravel, soft ground, slopes etc., can change operating capabilities of your machine.

## Proper Work Tools and Attachments

Only use work tools and attachments that are recommended by DOOSAN for use on DOOSAN machines. When installing and using optional attachments, read instruction manual for attachment, and general information related to attachments in this manual. Because DOOSAN cannot anticipate, identify or test all attachments that owners may want to install on their machines, contact DOOSAN for written authorization and approval of attachments, and their compatibility with optional kits.

Attachments and attachment control systems that are compatible with the machine are required for safe and reliable machine operation. Do not exceed maximum operating weight (machine weight plus attachment) that is listed on ROPS certification plate.

Make sure that all guards and shields are in place on machine and on work tool. Depending on type or combination of work equipment, there is a potential that work equipment could interfere with the cabin or other parts of machine. Before using unfamiliar work equipment, check if there is any potential of interference, and operate with caution.

While you are performing any maintenance, testing, or adjustments to attachments, stay clear of the following areas: cutting edges, pinch points, and crushing surfaces.

Never use attachment as a work platform or manlift.

Contact your DOOSAN distributor about auxiliary hydraulic kits for attachments installation. If you are in doubt about compatibility of a particular attachment with a machine, consult your DOOSAN distributor.

## Pressurized Fluids

Pressurized air or fluids can cause debris and/or fluids to be blown out. This could result in death or serious injury.

Immediately after operations are stopped, coolant, engine oil, and hydraulic oil are at their highest temperatures and the radiator and hydraulic tank are still under pressure. Always wait for temperature to cool down. Follow specified procedures when attempting to remove caps, drain oil or coolant, or replacing filters. Always wait for temperature to cool down, and follow specified procedures when performing these operations. Failure to do so can result in death or serious injury.

When pressurized air and/or pressurized water is used for cleaning, wear protective clothing, protective shoes, and eye protection. Eye protection includes goggles or a protective face shield.

Pressure can be trapped in a hydraulic system and must be relieved before maintenance is started.

Releasing trapped pressure can cause sudden machine movement or attachment movement. Use caution if you disconnect hydraulic lines or fittings.

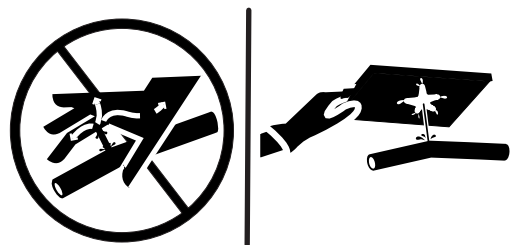

Figure 1

FG018457

High-pressure oil that is released can cause a hose to whip or oil to spray. Fluid penetration can result in death or serious injury. If fluid enters skin or eyes, get immediate medical attention from a physician familiar with this injury.

Obey all local laws and regulations for disposal of liquids.

To prevent hot coolant from spraying out, stop engine and wait for coolant to cool. Using gloves, slowly loosen cap to relieve pressure.

## Flying or Falling Objects

On work sites where there is a potential hazard that flying or falling objects can hit operator's cabin, select and use a guard to match operating conditions for additional operator protection.

Working in mines, tunnels, deep pits, and loose or wet surfaces, could produce hazard of falling rocks or flying objects. Additional protection for operator's cabin could be required such as an Operator Protection Guard (OPG) or window guards. Contact your DOOSAN distributor for information on available protective guards.

To prevent personnel from being struck by flying objects, keep personnel out of work area.

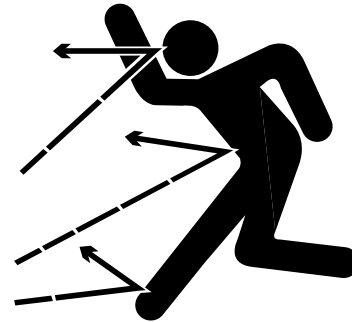

Figure 2

HAOA110L



Figure 3

HAOA100L



# Engine

Edition 1

# SAFETY INSTRUCTIONS

---



## WARNING

---

### AVOID DEATH OR SERIOUS INJURY

Instructions are necessary before operating or servicing machine. Read and understand the Operation & Maintenance Manual and signs (decals) on machine. Follow warnings and instructions in the manuals when making repairs, adjustments or servicing. Check for correct function after adjustments repairs or service. Untrained operators and failure to follow instructions can cause death or serious injury.

---

# OVERVIEW

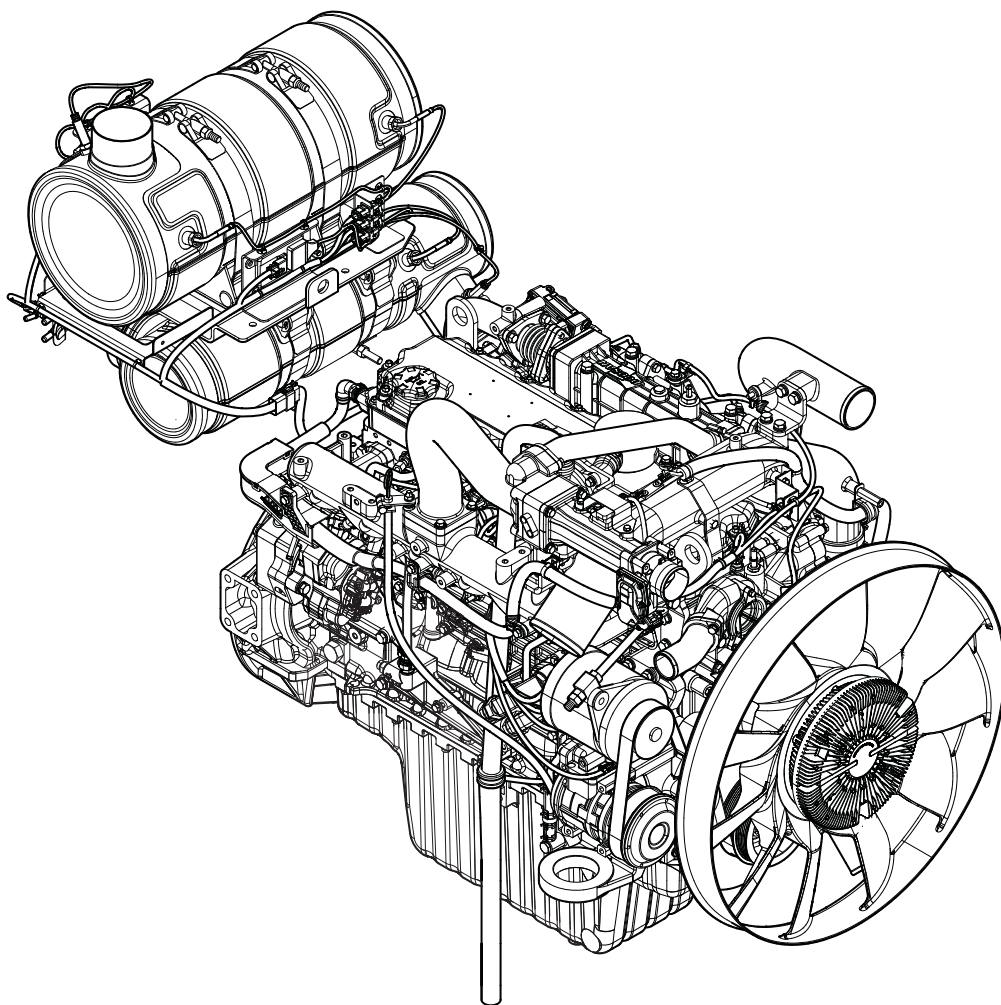

EX1403491

Figure 1

# GENERAL INFORMATION

## General Description

This manual provides the most efficient methods for engine maintenance as well as quick, efficient methods to determine the cause of engine faults to ensure that any actions taken by professionally certified maintenance technicians are done in the most efficient and efficient way possible. If maintenance is performed by unskilled technicians, or maintenance without the specified tools and facilities, serious bodily injury or critical faults in engine performance may occur. Regular inspection and maintenance are required to maintain long-term optimal engine conditions and best performance. In the event that a part must be replaced, only genuine parts as defined by the parts the list (Parts Book) should be used. Doosan shall not be held liable for any critical damage or faults which may be caused by the use of unauthorized or remanufactured parts. The maintenance methods stated in this Operation and Maintenance Manual are the most efficient and safest work procedures. Some work procedures require special tools.

For questions about genuine parts and special tools, please contact us.

This manual includes 'Danger', 'Warning', and 'Caution' in order to reduce possible injuries and engine faults which may occur while performing maintenance. If workers do not follow the instructions, critical faults in engine performance and operation or serious bodily injury may occurred. 'Danger', 'Warning', and 'Caution' instructions must be followed. However, we inform you that it is not possible to describe all possible and unexpected dangers which may arise while performing engine maintenance.

### Cautions for Starting the Engine

1. Before starting the engine, please read this manual carefully and fully understand 'Danger', 'Warning', and 'Caution'. If you cannot fully understand it or have any question, please contact us.
2. For safety reasons, attach "Warning" signs around engines in operation to keep people other than workers from accessing the engines. Let engine operators know that they are responsible for the safety of the engine room.
3. Only authorized people may start and operate engines. Unauthorized people should not be allowed to handle engines.
4. Do not access running or rotating parts while the engine is in operation.
5. Be careful not to touch or contact the engine during operation since it becomes hot during operation.
6. Exhaust gas is poisonous. Fully ventilate before starting engine. If the space is airtight, ensure that it is well ventilated.

## Cautions for Inspection and Repair

1. Inspection and repair of engine should be performed only when the engine is stopped. Otherwise, burns or safety accidents may occur, so do not perform inspection or repair while the engine is running.
2. If it is absolutely necessary to perform inspection or repair on the operating engine, do not get close to the rotating parts.



### **DANGER**

---

#### **AVOID DEATH**

**When accessories such as necklaces, rings, watches, or gloves become stuck in rotating parts while the engine is running, serious bodily injury may occur.**

---



### **WARNING**

---

#### **AVOID DEATH OR SERIOUS INJURY**

**Do not exchange or disassemble a pipe or hose (from the engine fuel circuit, engine oil circuit, coolant circuit, or compressed air circuit) while the engine is running. The leaked liquid may cause bodily injuries.**

---

3. Use an engine oil drain container that is large enough to prevent the overflow of engine oil while draining engine oil.
  4. Open the engine coolant cap after fully cooling the engine to exchange or replenish coolant.
- 



### **WARNING**

---

#### **AVOID DEATH OR SERIOUS INJURY**

**If the coolant cap is opened while the engine is still hot, hot water will spurt out and may cause burns. Open the engine coolant cap after fully cooling the engine.**

---

5. Fuel is highly flammable. Smoking or use of fire around an engine may cause fire.
- 



### **WARNING**

---

#### **AVOID DEATH OR SERIOUS INJURY**

**Only refuel when the engine is stopped.**

---

6. Mark and separately manage the containers for storing coolant from beverage containers for avoiding confusion. See a doctor immediately in case of drinking coolant.
7. Follow the instructions provided by the battery manufacturer when checking or handling batteries.



## WARNING

---

### AVOID DEATH OR SERIOUS INJURY

**Battery fluid is corrosive and dangerous because of its explosiveness and toxicity. Therefore, it should only be handled by a skilled technician who specializes in battery fluid.**

---

8. Only certified professional technicians should repair and maintain engines.
9. Only appropriate tools should be used. If the jaws of a wrench are worn out, the wrench might slip during use, causing safety accidents.
10. Do not allow other persons to stay or pass under an engine when lifting the engine with a crane. Before lifting the engine, ensure that there is no one around the engine and reserve enough safety space.
11. Before inspecting or replacing the electrical apparatus, disconnect the battery ground wire first. Connect the battery ground wire after completing all required work for checking or replacing the electrical apparatus in order to prevent a short circuit.
12. Before performing electric welding works, turn off engine, block the power supply to the engine, and remove the wire harness connector connected to the engine control unit (ECU).
13. Do not give any electric or mechanical shocks or perform welding works on the electrical apparatus or the ECU.

### General Repair

1. Wait until the engine is properly cooled down before starting work, since you may get burned by the heated engine.  
  
Before performing fuel line work, check the common rail pressure and engine temperature by using the failure diagnosis device.
2. Disconnect the battery ground wire from to prevent damage of wires and sensors caused by a short circuit.
3. Engine oil and coolant may damage paint and should be stored in a separate container and marked for safe management.
4. Store the disassembled parts in a specified space to avoid damage or pollution.

**Buy Now**



Our support email:

[ebooklibonline@outlook.com](mailto:ebooklibonline@outlook.com)