



SERVICE MANUAL

EXCAVATOR
JS200, JS210, JS220, JS235

EN - 9813/7350 - ISSUE 1 - 04/2016

This manual contains original instructions, verified by the manufacturer (or their authorized representative).

Copyright 2016 © JCB SERVICE
All rights reserved. No part of this publication may be reproduced, stored in a retrieval system, or transmitted in any form or by any other means, electronic, mechanical, photocopying or otherwise, without prior permission from JCB SERVICE.

www.jcb.com

Foreword

The Operator's Manual

You and others can be killed or seriously injured if you operate or maintain the machine without first studying the Operator's Manual. You must understand and follow the instructions in the Operator's Manual. If you do not understand anything, ask your employer or JCB dealer to explain it.

Do not operate the machine without an Operator's Manual, or if there is anything on the machine you do not understand.

Treat the Operator's Manual as part of the machine. Keep it clean and in good condition. Replace the Operator's Manual immediately if it is lost, damaged or becomes unreadable.

Contents

01 - Machine

03 - Attachments and Options

06 - Body and Framework

09 - Operator Station

12 - Heating, Ventilating and Air-Conditioning (HVAC)

15 - Engine

18 - Fuel and Exhaust System

21 - Cooling System

27 - Driveline

30 - Hydraulic System

33 - Electrical System

72 - Fasteners and Fixings

75 - Consumable Products

78 - After Sales

Operation

Refer to Camshaft-Operation (PIL 15-15).

Lubrication

Oil is fed from the main gallery via five drillings, one to each of the main bearings. A groove around the

diameter of the upper main bearing shell allows oil transfer to cross drillings in the crankshaft to feed each of the big end bearings. Crankshaft gear is 'splash' lubricated. Front and rear crankshaft oil seals prevent oil leakage from, and dirt ingress to, the engine.

Figure 119.

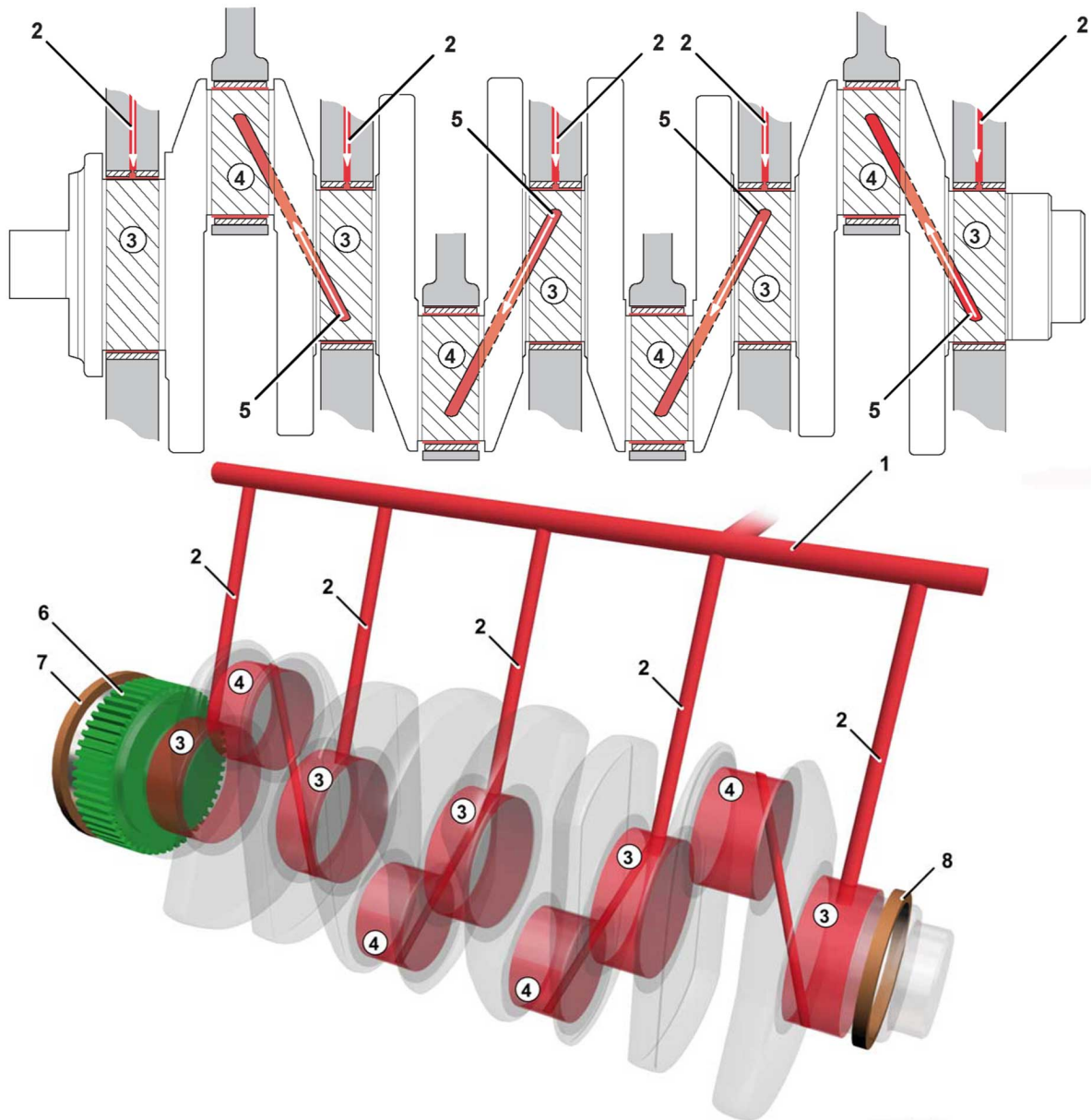

- 1 Main gallery
- 3 Main bearings
- 5 Cross drillings
- 7 Crankshaft oil seal

- 2 Drillings (x5)
- 4 Big end bearings
- 6 Crankshaft gear
- 8 Crankshaft oil seal

Check (Condition)

1. Check the main bearing surfaces for damage and excessive wear.

Figure 120.

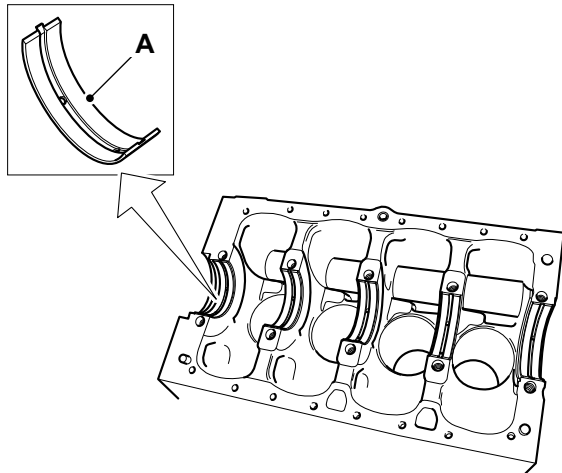

A Main bearing shells

2. Measure the crankshaft diameters to confirm they are within service limits, refer to Technical Data (PIL 15-12).

Figure 121.

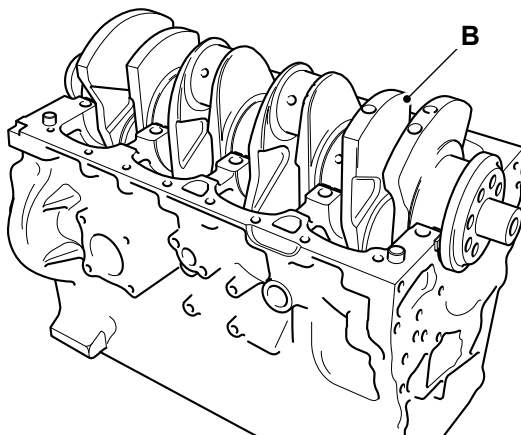

B Crankshaft

3. Check that the oil-way cross drillings in the crankshaft are clear and free from debris. Blocked or restricted oil-ways will cause oil starvation at the big end bearings.
4. Check that the piston cooling J-jets are clear. If the J-jets cannot be cleared remove the fixing screws. Remove the J-jets and discard them.
5. Install new J-jets.

Figure 122.

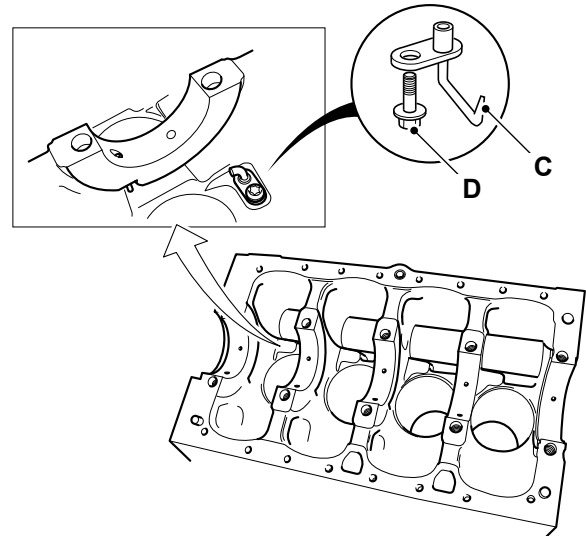

C J-jets
D Fixing screws

Remove and Install

Consumables

Description	Part No.	Size
Cleaner/Degreaser - General purpose solvent based parts cleaner	4104/1557	0.4L

▲ CAUTION This component is heavy. It must only be removed or handled using a suitable lifting method and device.

Before Removal

1. This procedure requires service parts. Make sure you have obtained the correct service parts before you start, refer to Parts Catalogue.
2. Make sure that the engine is safe to work on. If the engine has been running, let it cool before you start the service work.
3. Remove the engine, refer to (PIL 15-00).
4. Remove the drive belt, refer to (PIL 15-18).
5. Remove the crankshaft pulley, refer to (PIL 15-12).
6. Remove the oil sump, refer to (PIL 15-45).
7. Disconnect and remove the fuel pipes from the injectors, refer to (PIL 18-96).
8. Remove the rocker cover, refer to (PIL 15-42).
9. Remove the fuel injectors, refer to (PIL 18-18).
10. Remove the rocker assembly including the push rods, refer to (PIL 15-42).
11. It is not necessary to remove the cylinder head assembly to remove the crankshaft. If however the cylinder head needs to be removed for other

reasons (for piston and connecting rod removal for example) remove it now, refer to (PIL 15-06).

12. Remove the fuel injection pump, refer to (PIL 18-18).
13. Remove the starter motor, refer to (PIL 15-75).
14. Remove the high duty PTO device (if installed).
15. Position the engine upside down in a suitable jig or fixture, supported at the front of the cylinder block.
16. Remove the flywheel, refer to (PIL 15-54).
17. Remove the flywheel housing, refer to (PIL 15-54).
18. Remove the fuel injection pump drive gear, refer to (PIL 15-51).
19. Remove the oil pump, refer to (PIL 15-60).
20. Remove the high duty PTO idler drive gear (if installed), refer to (PIL 15-51).
21. Remove the crankshaft drive gear, refer to (PIL 15-51).
22. Remove the camshaft, refer to (PIL 15-15).
23. Remove the rear timing case, refer to (PIL 15-51).
24. If the pistons and connecting rods have not been removed, undo and remove the main bearing caps, refer to (PIL 15-12).
25. Remove the bedplate, refer to (PIL 15-09).

Remove

1. Remove the thrust washers between the crankshaft and crankcase rear main bearing.

Figure 123.

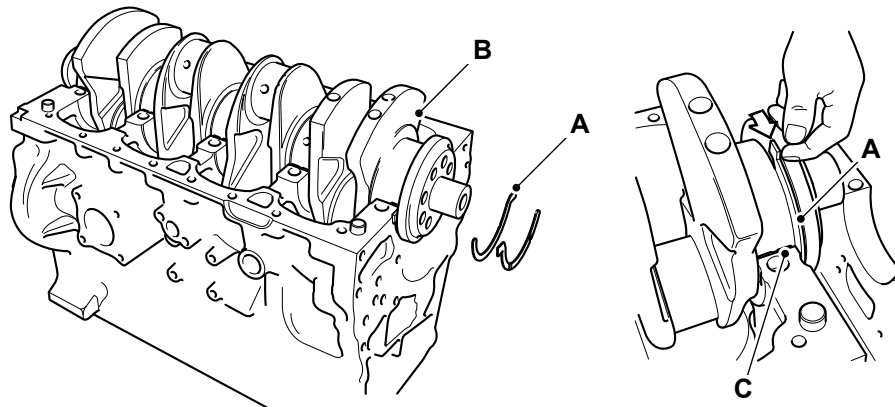

- A** Thrust Washers
- C** Rear main bearing

- B** Crankshaft

2. Put labels on the thrust washers to make sure that they are installed in the correct positions during assembly.
3. Use suitable lifting equipment to carefully lift the crankshaft from the crankcase (if the crankshaft is lifted manually, two people will be required).
4. Carefully lift out the bearing shells.

Before Installation

1. Clean off all traces of the old sealant compound from the crankcase and bedplate mating faces.
2. Use a suitable degreasing agent to carefully clean the main bearing saddles in the bedplate and crankcase. Take care not to block the oil ways or the piston cooling jets.

Consumable: [Cleaner/Degreaser - General purpose solvent based parts cleaner](#)

Important: Cleanliness is of the utmost importance. Blocked oil-ways or oil jets will cause engine failure. Before you install the crankshaft make sure that ALL oil-ways and jets are clear and free from debris.

Figure 124.

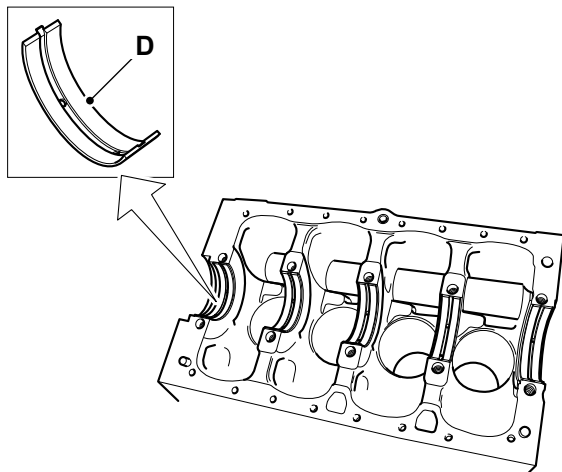

- D** Main bearing shells

5. It is recommended that the bearing shells are replaced. If however they are to be used again, put label on the shells to make sure that they are installed in their original positions during assembly.
6. Inspect the crankshaft and main bearings etc. for damage and excessive wear. Refer to Check Condition (PIL 15-12).

Install

1. Replacement is the reversal of the removal procedure.
2. Make sure that all items are clean and free from damage and corrosion.
3. If removed or a new crankcase is being installed then install cooling J jets as follows:

Figure 125.

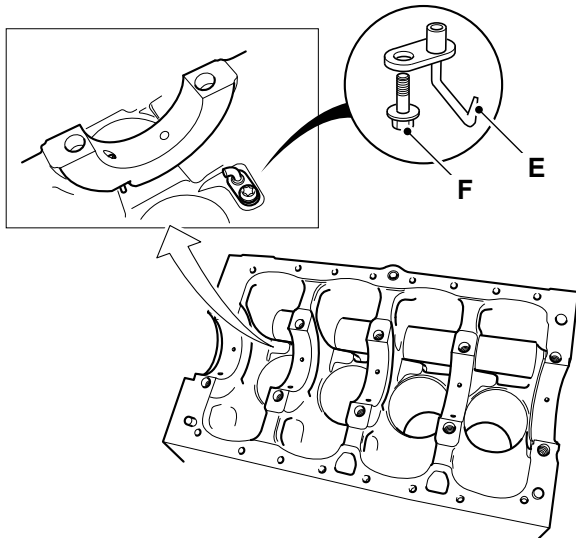

E J jets (x4)
F Fixing screws

- 3.1. Insert the cooling jets into the crankcase.
- 3.2. Note: There are different types of cooling jets installed depending on the engine application. The jets are colour coded.
- 3.3. Be sure to install the correct jets. Refer to the relevant parts catalogue for the correct cooling jet identification.
- 3.4. Tighten the retaining screws to the correct torque value.

4. Install the upper bearing shells as follows:

Figure 126.

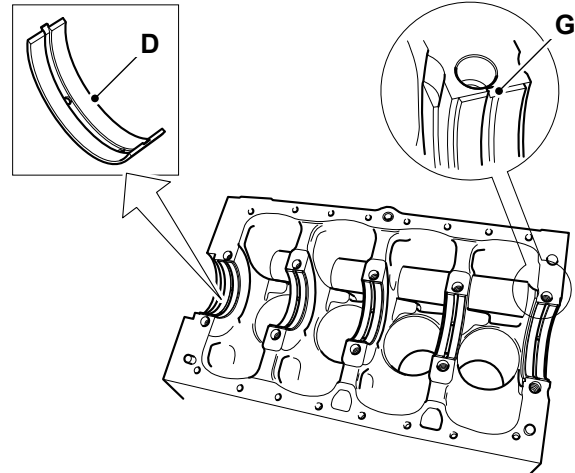

D Main bearing shells
G Bearing location tab

- 4.1. Use a suitable degreasing agent to make sure that the surface of the upper bearing shells are clean.
[Consumable: Cleaner/Degreaser - General purpose solvent based parts cleaner](#)
- 4.2. Assemble the bearing shells into the crankcase bearing saddles. Make sure that the location tab engages into the slot as shown.
- 4.3. Important: Make sure that the oil-way holes in the bearing saddles align with the holes in the bearing shell. If the holes are even partially misaligned the piston cooling oil jet will be restricted, causing the engine to fail.
- 4.4. Lubricate the upper bearing shells with clean engine oil.
5. Use suitable lifting equipment (if the crankshaft is lifted manually, two people will be required), to carefully lower the crankshaft into the crankcase. DO NOT rotate the crankshaft, the bearing shells can become dislodged, refer to step 4.
6. Install the thrust washers as follows:

Figure 127.

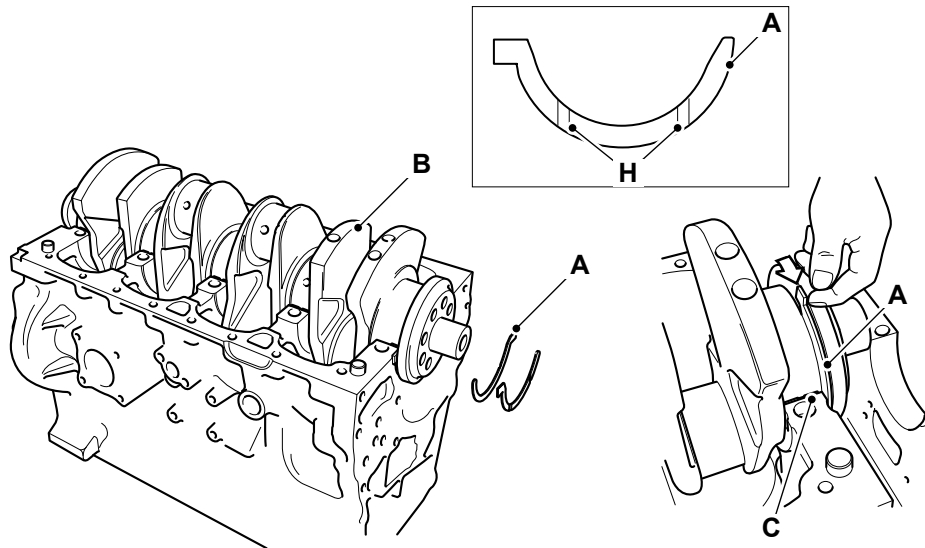

A Thrust washers
C Rear main bearing

B Crankshaft
H Oil slot - thrust washers

- 6.1. Slide the thrust washers between the crankshaft and the crankcase rear main bearing.
 - 6.2. Make sure that they are installed in the correct positions, with the two slots facing outwards from the bearing saddle.
 - 6.3. If necessary, push the crankshaft forward and then backwards to obtain clearance to install the thrust washers.
 - 6.4. DO NOT rotate the crankshaft, the bearing shells can become dislodged, refer to step 4.
7. Check that the crankshaft end float is within service limits, refer to Technical Data (PIL 15-12).

Table 61. Torque Values

Item	Nm
F	24

03 - Main Bearing

Introduction	15-70
Check (Condition)	15-71
Remove and Install	15-71

Introduction

In a piston engine, the main bearings are the bearings on which the crankshaft rotates.

The bearings hold the crankshaft in place and prevent the forces created by the piston and transmitted to the crankshaft by the connecting rods from dislodging the crankshaft, instead forcing the crank to convert the reciprocating movement into rotation.

Figure 128.

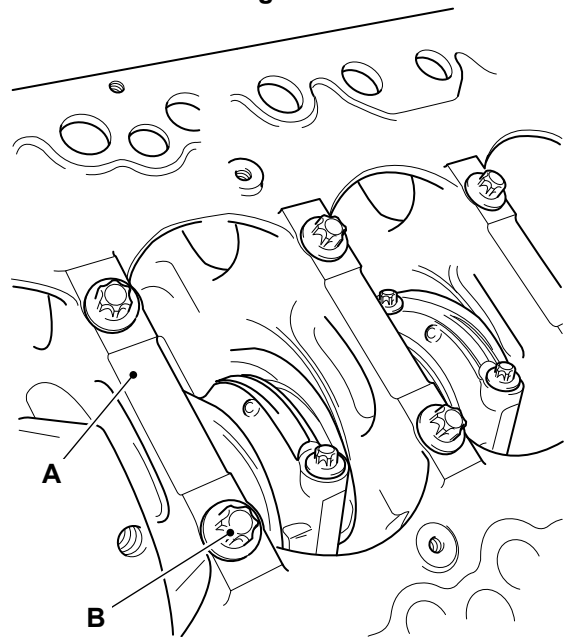

- A** Main bearing
- B** Main bearing bolts

Check (Condition)

1. Check the bearing shell surfaces for signs of damage and excessive wear.
2. Measure the crank pin diameters to confirm they are within service limits, refer to Technical Data (PIL 15-12).
3. Renew any parts that are worn or not within the specified tolerances.

Remove and Install

Refer to Crankshaft- Remove and Install. Refer to (PIL 15-12).

06 - Front Oil Seal

Remove and Install

Special Tools

Description	Part No.	Qty.
Crankshaft Front Oil Seal Installation Tool	892/01157	1

Before Removal

1. This procedure requires service parts. Make sure you have obtained the correct service parts before you start, refer to Parts Catalogue.
2. Make sure that the engine is safe to work on. If the engine has been running, let it cool before you start the service work.

3. Get access to the engine.
4. Remove the drive belt, refer to (PIL 15-18).
5. Remove the crankshaft pulley, refer to (PIL 15-12-12).

Remove

1. Use a suitable lever behind the lip of the seal, carefully prise out the oil seal from the counterbore in the crankcase. Take care not to scratch or damage the counterbore or the crankshaft hub. Damaged or dirty sealing faces will cause the oil seal to fail.

Figure 129.

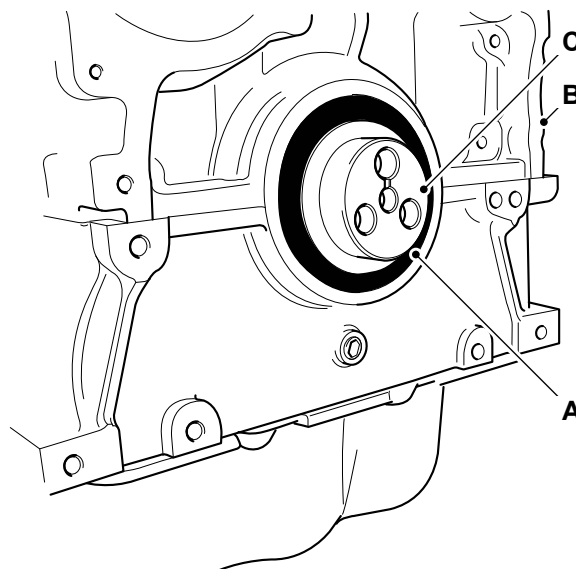

A Crankshaft oil seal
 C Crankshaft hub

B Crankcase

Install

1. Make sure that the counterbore and the crankshaft hub are clean and free from damage and corrosion. Use a suitable degreasing agent to clean all traces of oil and grease from the counterbore. Important: The oil seal has a special coating and MUST be installed dry without lubricant.

2. Dismantle the seal installation tool. Bolt the centre body to the crankshaft hub, using the bolts. Refer to Figure 130.

Special Tool: Crankshaft Front Oil Seal Installation Tool (Qty.: 1)

3. Install the oil seal on to the centre body. Make sure that the seal is installed the correct way around. Assemble the outer sleeve on to the centre body and install the screw. Refer to Figure 130.

Figure 130.

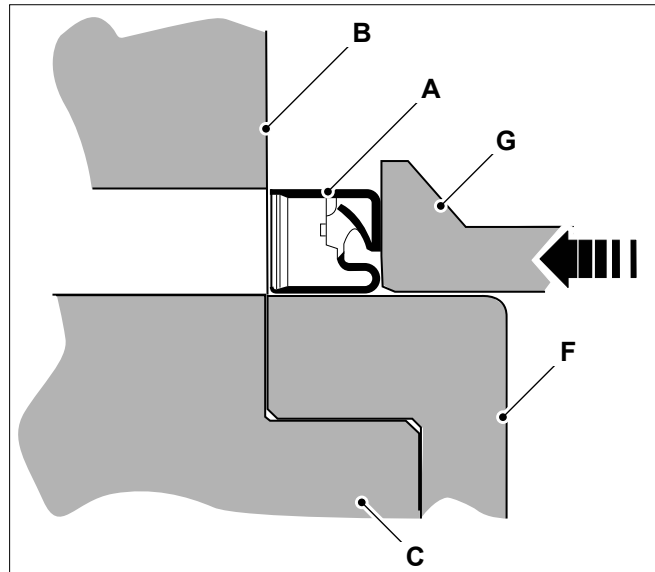
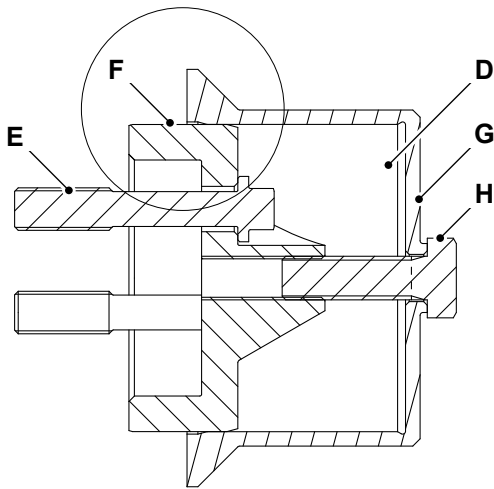

- A** Crankshaft oil seal
- C** Crankshaft hub
- E** Fixing bolts (x3)
- G** Outer sleeve

- B** Crankcase
- D** Seal installation tool
- F** Centre body
- H** Screw

4. Turn the screw to push the seal squarely into the counterbore until the outer sleeve comes up against the front edge of the counterbore. When correctly installed, the front face of the seal should be flush with the edge of the counterbore within the specified tolerance. Refer to Figure 131.

Dimension: $-0.5 -0/+0.5\text{mm}$

Figure 131.

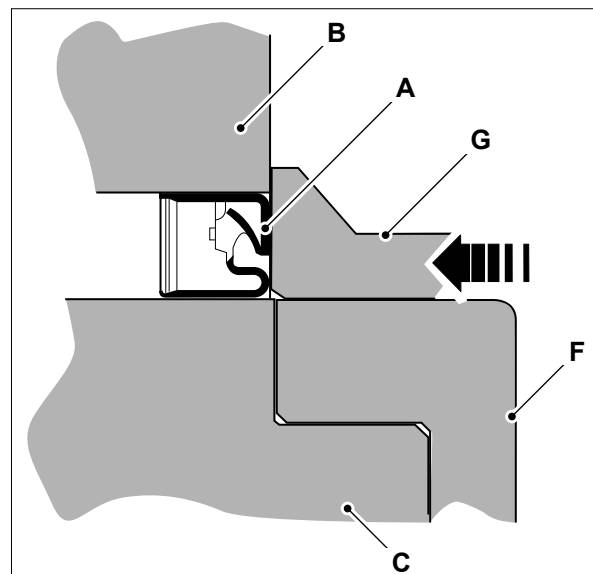

- A** Crankshaft oil seal
- B** Crankcase
- C** Crankshaft hub
- F** Centre body
- G** Outer sleeve

5. Remove the seal installation tool.

After Installation

1. Install the crankshaft pulley, refer to (PIL 15-12-12).
2. Install the drive belt, refer to (PIL 15-18).

09 - Rear Oil Seal

Remove and Install

Special Tools

Description	Part No.	Qty.
Crankshaft Rear Oil Seal Installation Tool	892/01156	1
Crankshaft Rear Oil Seal Alignment Tool	892/01158	1

Note: The flywheel hub and crankshaft rear oil seal need to be replaced as a pair.

Before Removal

1. This procedure requires service parts. Make sure you have obtained the correct service parts before you start, refer to Parts Catalogue.
2. Make sure that the engine is safe to work on. If the engine has been running, let it cool before you start the service work.
3. Get access to the engine.
4. Remove the flywheel, refer to (PIL 15-54).

Remove

1. Use a suitable lever behind the lip of the seal to carefully prise out the rear oil seal from the counterbore in the flywheel housing. Take care not to scratch or damage the counterbore or the flywheel hub. Damaged or dirty sealing faces will cause the oil seal to fail.

Figure 132. 24mm Hub

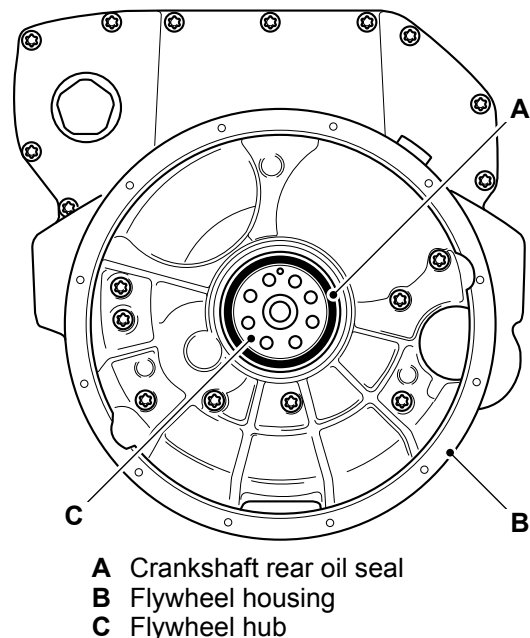

- A Crankshaft rear oil seal
- B Flywheel housing
- C Flywheel hub

Figure 133. 15mm Hub

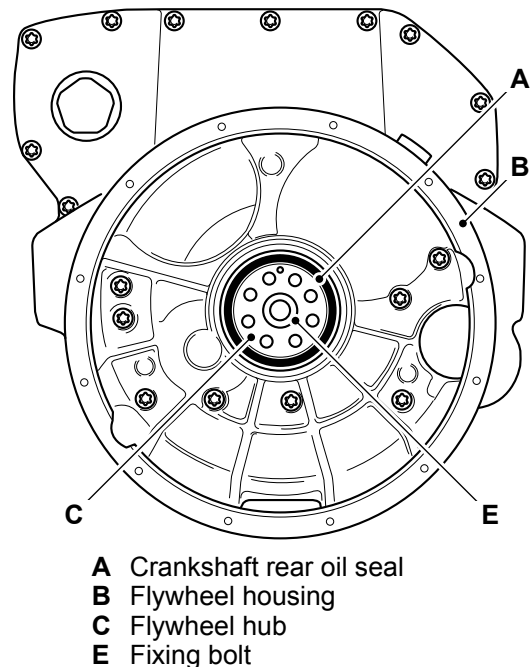

- A Crankshaft rear oil seal
- B Flywheel housing
- C Flywheel hub
- E Fixing bolt

Install (24mm Hub)

1. Make sure that the counterbore and the flywheel hub are clean and free from damage and corrosion.

Figure 134.

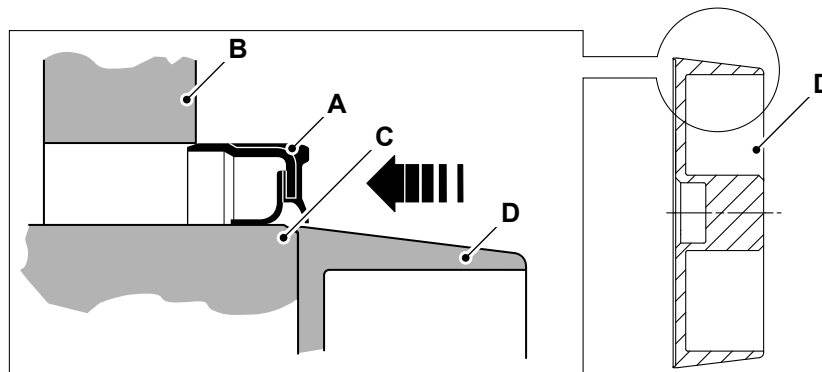

- A** Crankshaft rear oil seal
- C** Flywheel hub

- B** Flywheel housing
- D** Oil seal alignment tool

2. To prevent the seal lip rolling over and becoming damaged, make sure that you use the oil seal alignment tool to initially install the oil seal on to the flywheel hub. Locate the alignment tool over the end of the hub, then carefully push the oil seal over the alignment tool and on to the crankshaft diameter. Make sure that the oil seal is installed the correct way around.

Special Tool: Crankshaft Rear Oil Seal Alignment Tool (Qty.: 1)

3. Apply lubricant P80 around the seal outer rubber diameter.
4. Dismantle the oil seal installation tool. Bolt the centre body to the flywheel hub, using the two flywheel bolts. Assemble the outer sleeve on to the centre body and install the screw.

Special Tool: Crankshaft Rear Oil Seal Installation Tool (Qty.: 1)

Figure 135.

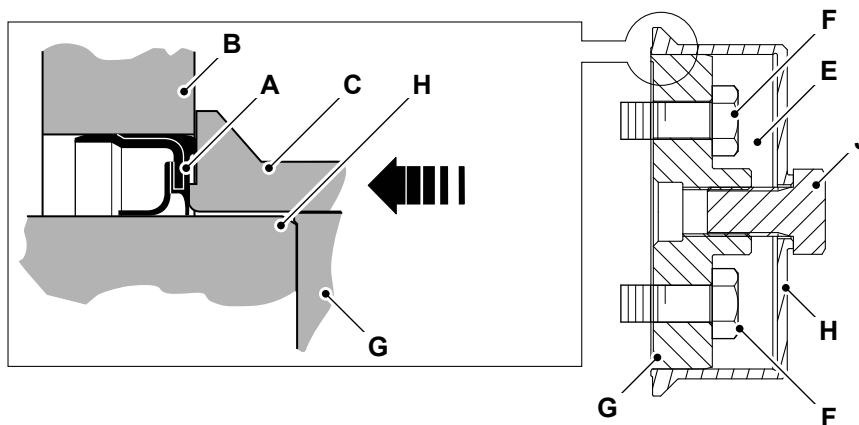

- A** Crankshaft rear oil seal
- C** Outer sleeve
- F** Flywheel bolts
- H** Flywheel hub

- B** Flywheel housing
- E** Oil seal installation tool
- G** Centre body
- J** Screw

5. Turn the screw to push the seal squarely into the counterbore until the outer sleeve comes up against the front edge of the counterbore. When correctly installed, the front face of the seal should be flush with the edge of the counterbore within the tolerance specified.

6. Remove the oil seal installation tool.

Install (15mm Hub)

1. Make sure that the counterbore and the hub are clean and free from damage.

Length/Dimension/Distance: 0.5mm

Buy Now



Our support email:

ebooklibonline@outlook.com