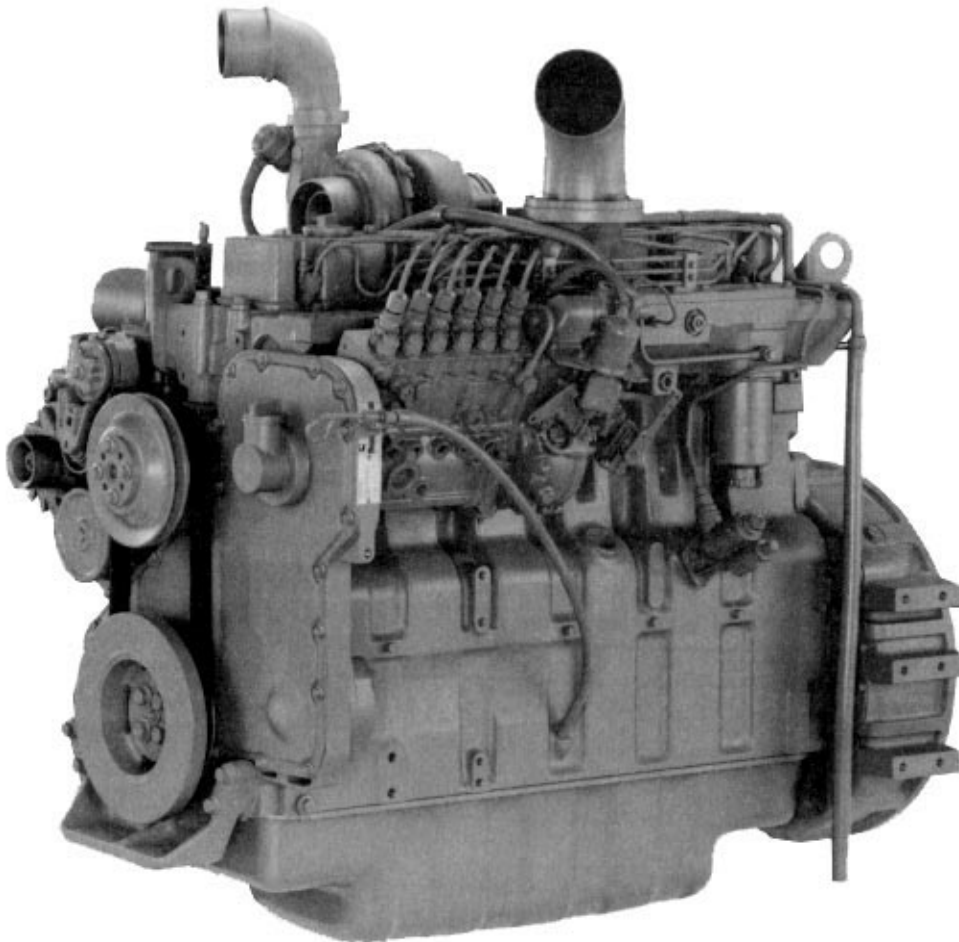

WORKSHOP MANUAL SERIE C CUMMINS ENGINES

Workshop manual integration of the following models:

EX255 - EX285 - FH270

G170 - G200 - FG75A - FG85A + FG105A

W170 - W190 - W230



All information, illustrations and specifications in this manual are based on the latest product information available at the time of publication.

The right is reserved to make changes at any time without notice.



Troubleshooting and Repair Manual C Series Engines

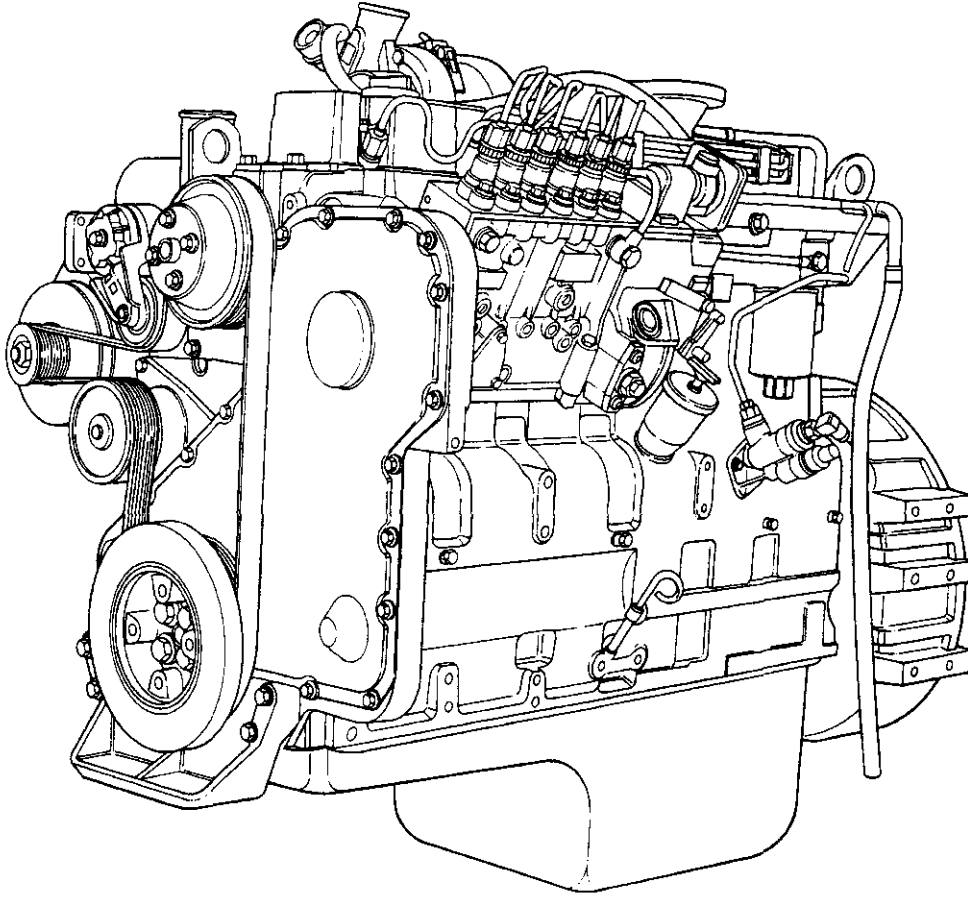

ew900gu

Foreword

This manual provides instructions for troubleshooting and repairing this engine in the chassis. Component and assembly rebuild procedures are provided in the engine shop manual. Refer to Section i - Introduction for instructions on how to use this manual.

Read and follow all safety instructions. Refer to the WARNING in the General Safety Instructions in Section i - Introduction.

The manual is organized to guide a service technician through the logical steps of identifying and correcting problems related to the engine. This manual does not cover vehicle or equipment problems. Consult the vehicle or equipment manufacturer for repair procedures.

A series of specific service manuals (for example: Shop, Specifications, and Alternative Repair) are available and can be ordered by filling out and mailing the Literature Order Form located in Section L - Service Literature.

The repair procedures used in this manual are recommended by Cummins Engine Co., Inc. Some service procedures require the use of special service tools. Use the correct tools as described.

Cummins Engine Company, Inc. encourages the user of this manual to report errors, omissions, and recommendations for improvement. Please use the postage paid, pre-addressed Literature Survey Form in the back of this manual for communicating your comments.

The specifications and rebuild information in this manual are based on the information in effect at the time of printing. Cummins Engine Company, Inc. reserves the right to make any changes at any time without obligation. If differences are found between your engine and the information in this manual, contact a Cummins Authorized Repair Location or call 1-800-DIESELS (1-800-343-7357) toll free in the U.S. and Canada.

The latest technology and the highest quality components are used to manufacture Cummins engines. When replacement parts are needed, we recommend using only genuine Cummins or ReCon® exchange parts. These parts can be identified by the following trademarks:



Table of Contents

| | Section |
|---|---------|
| Introduction | i |
| Engine Identification | E |
| Troubleshooting Symptoms | TS |
| Complete Engine - Group 00 | 0 |
| Cylinder Block - Group 01 | 1 |
| Cylinder Head - Group 02 | 2 |
| Rocker Levers - Group 03 | 3 |
| Cam Followers/Tappets - Group 04 | 4 |
| Fuel System - Group 05 | 5 |
| Injectors and Fuel Lines - Group 06 | 6 |
| Lubricating Oil System - Group 07 | 7 |
| Cooling System - Group 08 | 8 |
| Air Intake System - Group 10 | 10 |
| Exhaust System - Group 11 | 11 |
| Compressed Air System - Group 12 | 12 |
| Electrical Equipment - Group 13 | 13 |
| Engine Testing - Group 14 | 14 |
| Mounting Adaptations - Group 16 | 16 |
| Miscellaneous - Group 17 | 17 |
| Service Literature | L |
| Component Manufacturers | M |
| Specifications | V |
| Index | X |

Section i - Introduction

Section Contents

| | Page |
|--|------|
| About the Manual | i-1 |
| Acronyms and Abbreviations | i-7 |
| General Cleaning Instructions | i-6 |
| Glass or Plastic Bead Cleaning | i-6 |
| Solvent and Acid Cleaning | i-6 |
| Steam Cleaning | i-6 |
| General Repair Instructions | i-5 |
| General Safety Instructions | i-4 |
| Important Safety Notice | i-4 |
| How to Use the Manual | i-1 |
| Illustrations | i-3 |
| Symbols | i-2 |

About the Manual

This C Series Engine Troubleshooting and Repair Manual is intended to aid in determining the cause of engine-related problems and to provide recommended repair procedures. The manual is divided into sections by system. Each section provides general information, specifications, diagrams, and service tools, where applicable. The specific repair procedures are referenced in the Troubleshooting Symptoms Charts.

How to Use the Manual

This manual is organized to provide an easy flow from problem identification to problem correction. A list of troubleshooting symptoms containing the most common engine problems is in the Troubleshooting Symptoms, Section TS. This manual is designed to use the Troubleshooting Symptoms as a guide in locating the problem and directing the end user to the correct procedure for making the necessary repairs to the engine. Complete the following steps to locate and correct any problems:

1. Locate the symptom on the Section Contents page of Section TS.
2. Reference to the page number where the Troubleshooting Symptom Tree is found is made to the right of the symptom tree title.
3. The left column of boxes in the Troubleshooting Symptom Charts indicates a probable cause of the problem, starting at the top with the simplest and easiest to repair, and continuing downward to the most difficult.
4. The right column of boxes provides a brief description of the corrective action with a reference number to the correct procedure used to make the repair.
5. Locate the probable cause in the left column then turn to the procedure referenced in the right column.

The Trouble shooting Symptom Charts are based on the following assumptions:

- The engine has been installed according to the OEM's specifications.
- The easiest repairs are done first.
- "Generic" solutions to cover problems with the most common applications and OEM.

Refer to Section V for specifications recommended by Cummins Engine Company, Inc. for your engine. Specifications and torque values for each engine system are given in Section V.

Symbols

The following symbols have been used in this manual to help communicate the intent of the instructions. When one of the symbols appears, it conveys the meaning defined below:



WARNING - Serious personal injury or extensive property damage can result if the warning instructions are not followed.



CAUTION - Minor personal injury can result or a part, an assembly, or the engine can be damaged if the caution instructions are not followed.



Indicates a **REMOVAL** or **DISASSEMBLY** step.



Indicates an **INSTALLATION** or **ASSEMBLY** step.



INSPECTION is required.



CLEAN the part or assembly.



PERFORM a mechanical or time **MEASUREMENT**.



LUBRICATE the part or assembly.



Indicates that a **WRENCH** or **TOOL SIZE** will be given.



TIGHTEN to a specific torque.



PERFORM an electrical **MEASUREMENT**.



Refer to another location in this manual or another publication for additional information.



The component weighs 23 kg [50 lb] or more. To avoid personal injury, use a hoist or get assistance to lift the component.

Illustrations

Some of the illustrations throughout this manual are generic and will **not** look exactly like the engine or parts used in your application. The illustrations can contain symbols to indicate an action required and an acceptable or **not** acceptable condition.

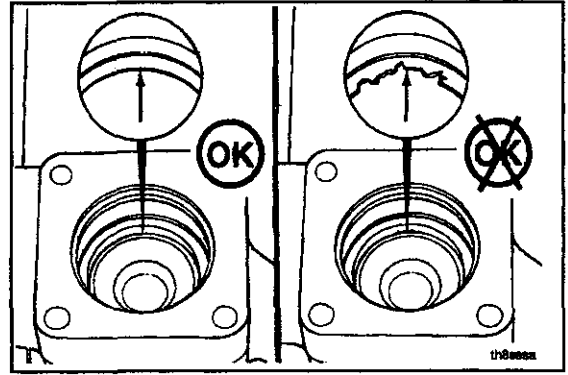

The illustrations are intended to show repair or replacement procedures. The procedure will be the same for all applications, although the illustration can differ.

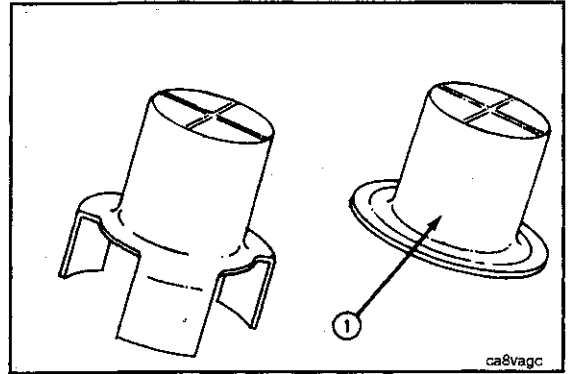

General Safety Instructions

Important Safety Notice

▲ WARNING ▲

Improper practices or carelessness can cause burns, cuts, mutilation, asphyxiation or other bodily injury or death.

Read and understand all of the safety precautions and warnings before performing any repair. This list contains the general safety precautions that **must** be followed to provide personal safety. Special safety precautions are included in the procedures when they apply.

- Make sure the work area surrounding the product is dry, well lit, ventilated, free from clutter, loose tools, parts, ignition sources and hazardous substances. Be aware of hazardous conditions that can exist.
- **Always** wear protective glasses and protective shoes when working.
- Rotating parts can cause cuts, mutilation or strangulation.
- Do **not** wear loose-fitting or torn clothing. Remove all jewelry when working.
- Disconnect the battery (negative [-] cable first) and discharge any capacitors before beginning any repair work. Disconnect the air starting motor if equipped to prevent accidental engine starting. Put a "Do Not Operate" tag in the operator's compartment or on the controls.
- Use **ONLY** the proper engine barring techniques for manually rotating the engine. Do **not** attempt to rotate the crankshaft by pulling or prying on the fan. This practice can cause serious personal injury, property damage, or damage to the fan blade(s) causing premature fan failure.
- If an engine has been operating and the coolant is hot, allow the engine to cool before you slowly loosen the filler cap and relieve the pressure from the cooling system.
- Do **not** work on anything that is supported **ONLY** by lifting jacks or a hoist. **Always** use blocks or proper stands to support the product before performing any service work.
- Relieve all pressure in the air, oil, fuel and the cooling systems before any lines, fittings, or related items are removed or disconnected. Be alert for possible pressure when disconnecting any device from a system that utilizes pressure. Do **not** check for pressure leaks with your hand. High pressure oil or fuel can cause personal injury.
- To prevent suffocation and frostbite, wear protective clothing and **ONLY** disconnect fuel and liquid refrigerant (freon) lines in a well ventilated area. To protect the environment, liquid refrigerant systems **must** be properly emptied and filled using equipment that prevents the release of refrigerant gas (fluorocarbons) into the atmosphere. Federal law requires capturing and recycling refrigerant.
- To avoid personal injury, use a hoist or get assistance when lifting components that weigh 23 kg [50 lb] or more. Make sure all lifting devices such as chains, hooks, or slings are in good condition and are of the correct capacity. Make sure hooks are positioned correctly. **Always** use a spreader bar when necessary. The lifting hooks **must not** be side-loaded.
- Corrosion inhibitor, a component of SCA and lubricating oil, contains alkali. Do **not** get the substance in your eyes. Avoid prolonged or repeated contact with skin. Do **not** swallow internally. In case of contact, immediately wash skin with soap and water. In case of contact, immediately flood eyes with large amounts of water for a minimum of 15 minutes. **IMMEDIATELY CALL A PHYSICIAN. KEEP OUT OF REACH OF CHILDREN.**
- Naptha and Methyl Ethyl Ketone (MEK) are flammable materials and **must** be used with caution. Follow the manufacturer's instructions to provide complete safety when using these materials. **KEEP OUT OF REACH OF CHILDREN.**
- To avoid burns, be alert for hot parts on products that have just been turned off, and hot fluids in lines, tubes, and compartments.
- **Always** use tools that are in good condition. Make sure you understand how to use them before performing any service work. Use **ONLY** genuine Cummins or Cummins ReCon® replacement parts.
- **Always** use the same fastener part number (or equivalent) when replacing fasteners. Do **not** use a fastener of lesser quality if replacements are necessary.
- Do **not** perform any repair when fatigued or after consuming alcohol or drugs that can impair your functioning.
- Some state and federal agencies in the United States of America have determined that used engine oil can be carcinogenic and can cause reproductive toxicity. Avoid inhalation of vapors, ingestion, and prolonged contact with used engine oil.
- Coolant is toxic. If **not** reused, dispose of in accordance with local environmental regulations.

General Repair Instructions

This engine incorporates the latest technology at the time it was manufactured; yet, it is designed to be repaired using normal repair practices performed to quality standards.

- **Cummins Engine Company, Inc. does not recommend or authorize any modifications or repairs to engines or components except for those detailed in Cummins Service Information. In particular, unauthorized repair to safety-related components can cause personal injury or death. Below is a partial listing of components classified as safety-related:**

Air Compressor
Air Controls
Air Shutoff Assemblies
Balance Weights
Cooling Fan
Fan Hub Assembly
Fan Mounting Bracket(s)
Fan Mounting Capscrews
Fan Hub Spindle
Flywheel
Flywheel Crankshaft Adapter

Flywheel Mounting Capscrews
Fuel Shutoff Assemblies
Fuel Supply Tubes
Lifting Brackets
Throttle Controls
Turbocharger Compressor Casing
Turbocharger Oil Drain Line(s)
Turbocharger Oil Supply Line(s)
Turbocharger Turbine Casing
Vibration Damper Mounting Capscrews

- **Follow all safety instructions noted in the procedures**
 - Follow the manufacturer's recommendations for cleaning solvents and other substances used during the repair of the engine. Some solvents and used engine oil have been identified by government agencies as toxic or carcinogenic. Avoid excessive breathing, ingestion and contact with such substances. **Always** use good safety practices with tools and equipment.
- **Provide a clean environment and follow the cleaning instructions specified in the procedures**
 - The engine and its components **must** be kept clean during any repair. Contamination of the engine or components will cause premature wear.
- **Perform the inspections specified in the procedures**
- **Replace all components or assemblies which are damaged or worn beyond the specifications**
- **Use genuine Cummins new or ReCon® service parts and assemblies**
 - The assembly instructions have been written to use again as many components and assemblies as possible. When it is necessary to replace a component or assembly, the procedure is based on the use of new Cummins or Cummins ReCon® components. All of the repair services described in this manual are available from all Cummins Distributors and most Dealer locations.
- **Follow the specified disassembly and assembly procedures to avoid damage to the components**

Complete rebuild instructions are available in the shop manual which can be ordered or purchased from a Cummins Authorized Repair Location. Refer to Section L — Service Literature for ordering instructions.

General Cleaning Instructions

Solvent and Acid Cleaning

Several solvent and acid-type cleaners can be used to clean the engine parts. Experience has shown that the best results can be obtained using a cleaner that can be heated to 90 to 95 degrees Celsius [180 to 200 degrees Fahrenheit]. A cleaning tank that provides a constant mixing and filtering of the cleaning solution will give the best results. **Cummins Engine Company, Inc. does not recommend any specific cleaners. Always follow the cleaner manufacturer's instructions.**

Remove all the gasket material, o-rings, and the deposits of sludge, carbon, etc., with a wire brush or scraper before putting the parts in a cleaning tank. Be careful **not** to damage any gasket surfaces. When possible, steam clean the parts before putting them in the cleaning tank.

▲ WARNING ▲

Acid is extremely dangerous and can cause personal injury and damage the machinery. Always provide a tank of strong soda water as a neutralizing agent.

Rinse all of the parts in hot water after cleaning. Dry completely with compressed air. Blow the rinse water from all of the capscrew holes and the oil drillings.

If the parts are **not** to be used immediately after cleaning, dip them in a suitable rustproofing compound. The rustproofing compound **must** be removed from the parts before installation on the engine.

Steam Cleaning

Steam cleaning can be used to remove all types of dirt that can contaminate the cleaning tank. It is a good way to clean the oil drillings.

▲ WARNING ▲

Wear protective clothing to prevent personal injury from the high pressure and extreme heat.

Do **not** steam clean the following parts:

- | | |
|--------------------------|--------------------|
| 1. Electrical Components | 4. Fuel Pump |
| 2. Wiring | 5. Belts and Hoses |
| 3. Injectors | 6. Bearings |

Glass or Plastic Bead Cleaning

Glass or plastic bead cleaning can be used on many engine components to remove carbon deposits. The cleaning process is controlled by the size of the glass or plastic beads, the operating pressure, and the cleaning time.

▲ CAUTION ▲

Do not use glass or plastic bead cleaning on aluminum piston skirts. Do not use glass bead cleaning on aluminum ring grooves. Small particles of glass or plastic will embed in the aluminum and result in premature wear. Valves, turbocharger shafts, etc., can also be damaged. Follow the cleaning directions listed in the procedures.

NOTE: Plastic bead blasting media, Part No. 3822735, can be used to clean aluminum ring grooves. Do **not** use any bead blasting media on pin bores or aluminum skirts.

Follow the equipment manufacturer's cleaning instructions. The following guidelines can be used to adapt to manufacturer's instructions:

1. Bead size:
 - a. Use U.S. size No. 16-20 for piston cleaning with plastic bead media, Part No. 3822735.
 - b. Use U.S. size No. 70 for piston domes with glass media.
 - c. Use U.S. size No. 60 for general purpose cleaning with glass media.
2. Operating Pressure:
 - a. Glass: Use 620 kPa [90 psi] for general purpose cleaning.
 - b. Plastic: Use 270 kPa [40 psi] for piston cleaning.
3. Steam clean or wash the parts with solvent to remove all of the foreign material and glass or plastic beads after cleaning. Rinse with hot water. Dry with compressed air.
4. Do **not** contaminate the wash tanks with glass or plastic beads.

Acronyms and Abbreviations

| | | | |
|-----------------------|---|------------|---------------------------------|
| AFC | Air Fuel Control | kPa | Kilopascal |
| API | American Petroleum Institute | LNG | Liquid Natural Gas |
| ASA | Air Signal Attenuator | LTA | Low Temperature Aftercooling |
| ASTM | American Society of Testing and Materials | MIP | Mixer Inlet Pressure |
| °C | Celsius | MPa | Megapascal |
| CARB | California Air Resources Board | mph | Miles Per Hour |
| C.I.D. | Cubic Inch Displacement | mpq | Miles Per Quart |
| CNG | Compressed Natural Gas | N•m | Newton-meter |
| CPL | Control Parts List | NG | Natural Gas |
| cSt | Centistokes | OEM | Original Equipment Manufacturer |
| ECM | Electronic Control Module | ppm | Parts Per Million |
| ECS | Emission Control System | psi | Pounds Per Square Inch |
| EPA | Environmental Protection Agency | PTO | Power Takeoff |
| EPS | Engine Position Sensor | rpm | Revolutions Per Minute |
| °F | Fahrenheit | SAE | Society of Automotive Engineers |
| GVW | Gross Vehicle Weight | SCA | Supplemental Coolant Additive |
| Hg | Mercury | STC | Step Timing Control |
| hp | Horsepower | VS | Variable Speed |
| H₂O | Water | VSS | Vehicle Speed Sensor |
| ICM | Ignition Control Module | | |
| km/l | Kilometers per Liter | | |

Section E - Engine Identification

Section Contents

| | Page |
|-------------------------------------|-------------|
| Engine Diagrams | E-12 |
| Engine Identification | E-1 |
| Cummins Engine Nomenclature | E-1 |
| Engine Dataplate | E-1 |
| Fuel Injection Pump Dataplate | E-1 |
| Specifications | E-3 |
| Air Intake System | E-5 |
| Batteries (Specific Gravity) | E-11 |
| Cooling System | E-4 |
| Electrical System | E-10 |
| Exhaust System | E-10 |
| Fuel System | E-3 |
| General Specifications | E-3 |

Buy Now



Our support email:

ebooklibonline@outlook.com