

1

Dominator 202 MEGA

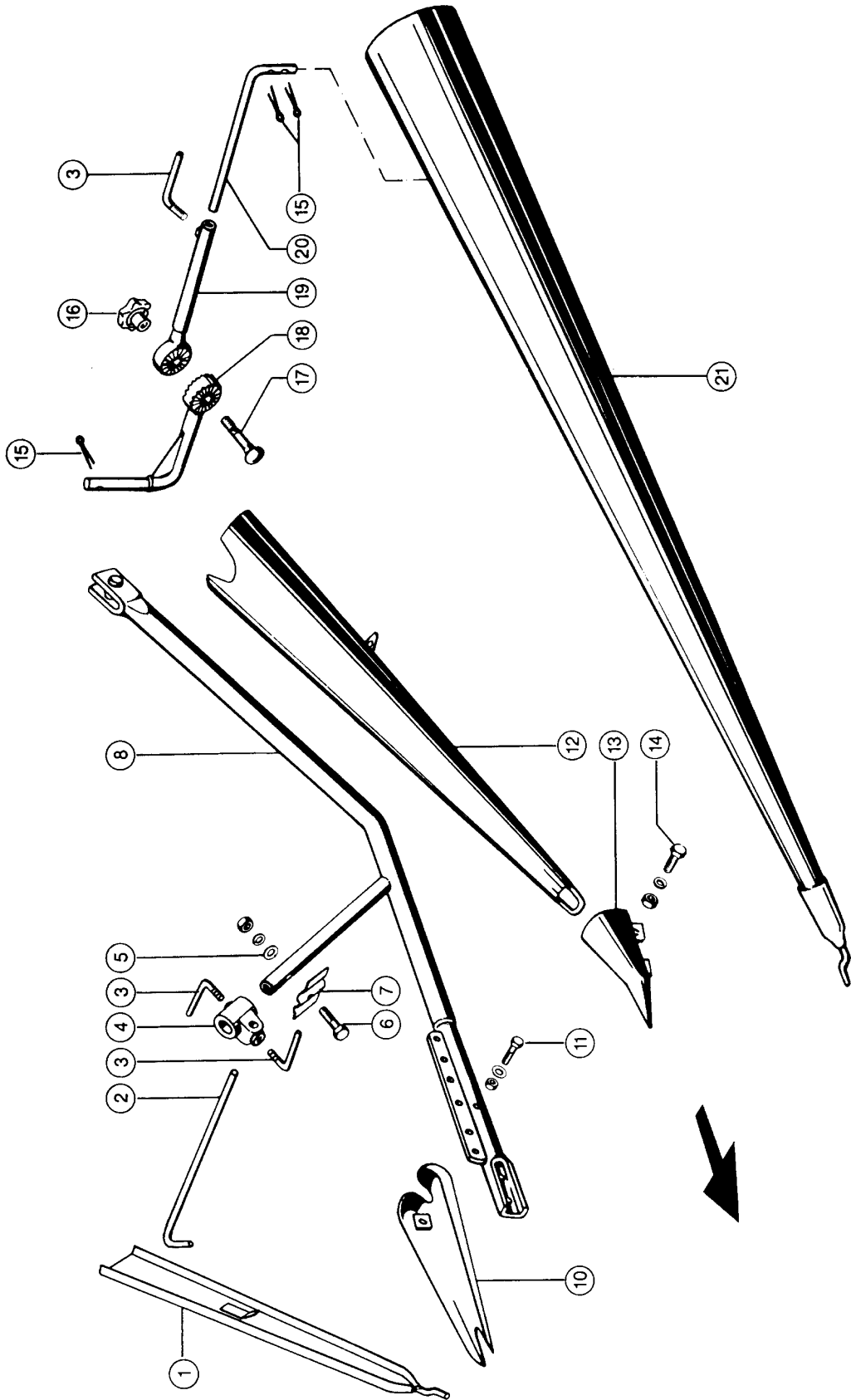

CLHHS

DIVIDER, VAR. 2556, 2527 1)

Pos.	Part No.	Description	Dimension	Quantity	Conditions
1	00 0612 558 1	INT.DIVIDER LONG	870 LANG	2	2)
1	00 0612 579 0	INT.DIVIDER SHORT	600 LANG	2	3)
2	00 0616 214 1	ADJUSTING ROD	D 12X490	2	
3	00 0500 924 2	TOMMY SCREW	M 12	6	
4	00 0609 887 0	CROSS BEARING		2	
5	00 0236 913 2	FLAT WASHER	10-10,5X20X2	4	
6	00 0235 533 0	HEX.HEAD BOLT	M10X45	4	
6	00 0236 171 0	HEXAGONAL NUT	M10	4	
6	00 0239 388 0	CONTACT WASHER	A10-10,2X22,25X1,6	4	
7	00 0609 888 1	INTERMED.PIECE	1,5X37X58	4	
8	00 0609 893 1	DIVIDER SUPP.TUBE	1800 LG	2	2)
8	00 0609 867 1	DIVIDER SUPP.TUBE	1540 LG	2	3)
10	00 0610 236 1	GLIDE SKID	320X115X50	2	
11	00 0235 519 0	HEXAGON HEAD BOLT	M 8X50	2	
11	00 0236 170 0	HEXAGONAL NUT	M8	2	
11	00 0239 387 0	CONTACT WASHER	A8-8,2X18X1,4	2	
12	00 0674 389 3	CENTR. SEPARAT.	1160 LANG	2	2)
12	00 0670 372 2	DIVIDER CEN.PLATE	840 LANG	2	3)
13	00 0520 020 1	POINT	230X105X90	2	
14	00 0237 383 0	HEXAGON HEAD BOLT	M10X25	4	
14	00 0236 171 0	HEXAGONAL NUT	M10	4	
14	00 0239 388 0	CONTACT WASHER	A10-10,2X22,25X1,6	4	
15	00 0235 097 0	SPLIT PIN	5X36	6	
16	00 0238 056 0	CONTROL KNOB	K 63-M12	1	4)
16	00 0504 504 0	HANDLE	N 100	1	5)
16	00 0238 056 0	CONTROL KNOB	K 63-M12	2	3)
17	00 0211 180 1	COACH BOLT	M12X 55	1	4)
17	00 0238 913 0	COACH BOLT	M12X 60	1	5)
17	00 0211 180 1	COACH BOLT	M12X 55	2	3)
18	00 0609 873 0	ADJUSTING PLATE		2	
19	00 0609 861 0	ADJUSTING TUBE	330 LANG	2	
20	00 0610 579 0	SUPPORT	D20X312	2	
21	00 0612 583 2	OUTER DIVIDER	2100 LANG	2	

1) Remarks VAR. 2556 = DIVIDER LONG
VAR. 2527 = DIVIDER SHORT

2) Remarks Var. 2556

3) Remarks VAR. 2527

4) Remarks Var. 2556 left

5) Remarks VAR. 2556 RECHTS

2

Dominator 202 MEGA

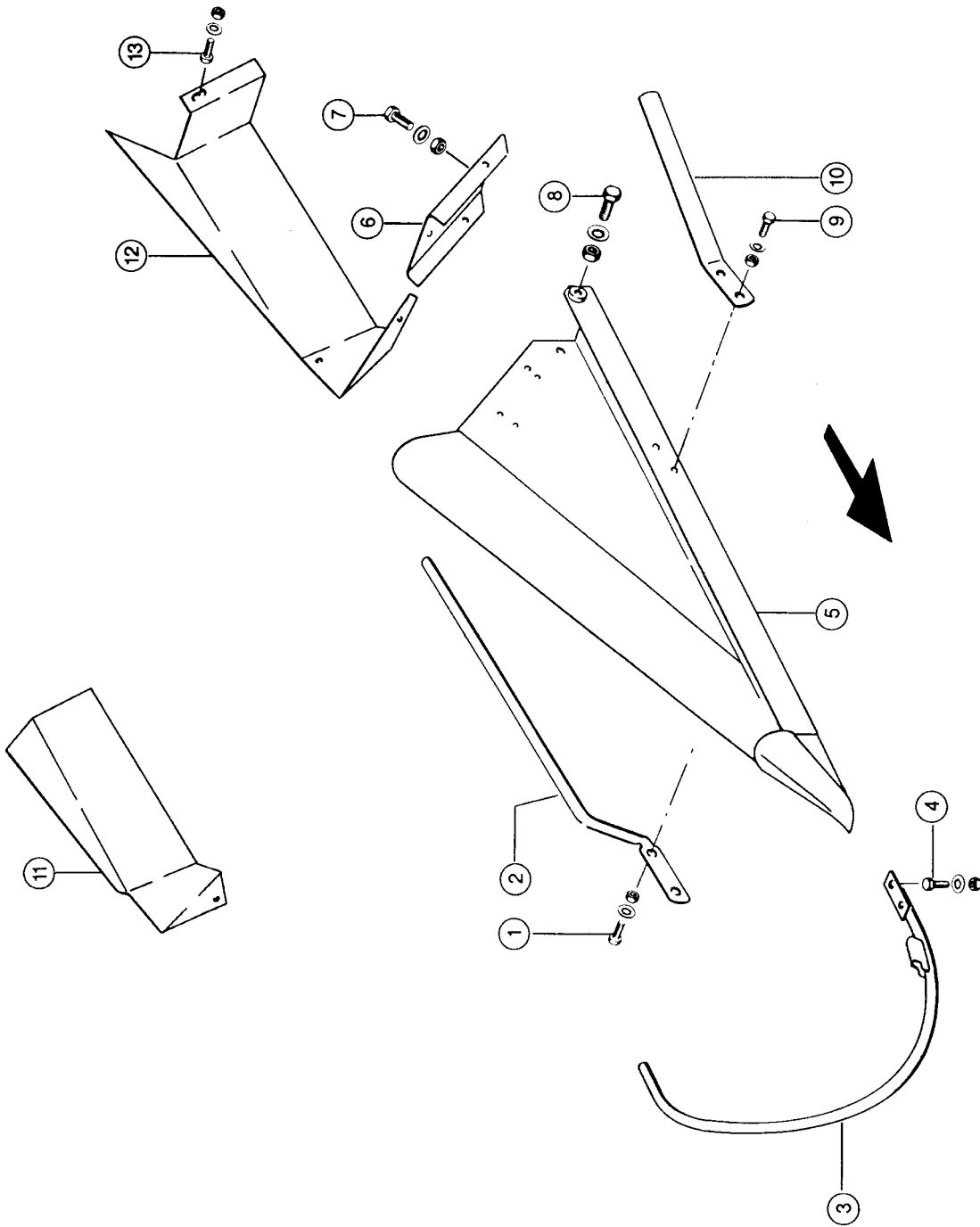

CLASH

SPECIAL CROP DIVIDER, VAR. 4282, 7633, 1)

Pos.	Part No.	Description	Dimension	Quantity	Conditions
1	00 0234 953 0	COACH BOLT	M8X20X13	4	2)
1	00 0236 170 0	HEXAGONAL NUT	M8	4	3)
1	00 0239 387 0	CONTACT WASHER	A8-8,2X18X1,4	4	3)
2	00 0688 975 1	DEFLECTOR INNER		2	2)
3	00 0688 025 0	BEND DIVIDER		2	4)
4	00 0237 442 0	HEXAGON HEAD BOLT	M8X25	4	4)
4	00 0236 170 0	HEXAGONAL NUT	M8	4	5)
4	00 0239 387 0	CONTACT WASHER	A8-8,2X18X1,4	4	5)
5	00 0688 969 1	DIVIDER L.H.		1	
5	00 0688 970 1	DIVIDER R.H.		1	
6	00 0688 974 0	SUPPORT	4X161X200	2	
7	00 0237 423 0	HEXAGON HEAD BOLT	M10X28	4	
7	00 0236 171 0	HEXAGONAL NUT	M10	4	
7	00 0239 388 0	CONTACT WASHER	A10-10,2X22,25X1,6	4	
8	00 0236 056 0	HEXAGON HEAD BOLT	M12X25	4	
8	00 0236 172 0	HEXAGONAL NUT	M12	4	
8	00 0239 389 0	CONTACT WASHER	A12	4	
9	00 0237 439 0	HEXAGON HEAD BOLT	M8X16	4	
9	00 0236 170 0	HEXAGONAL NUT	M8	4	
9	00 0239 387 0	CONTACT WASHER	A8-8,2X18X1,4	4	
10	00 0688 976 0	DEFLECTOR OUTER	3,0X0030X0400	2	
11	00 0670 069 1	DEFLECTOR R.H.	1,5X278,5X600	1	
12	00 0670 070 1	DEFLECTOR L.H.	1,5X0280X0600	1	
13	00 0237 439 0	HEXAGON HEAD BOLT	M8X16	2	
13	00 0236 170 0	HEXAGONAL NUT	M8	2	
13	00 0239 387 0	CONTACT WASHER	A8-8,2X18X1,4	4	

1)	Remarks	OPTION
2)	Remarks	at Var. 7777
3)	Remarks	BEI VAR. 7777
4)	Remarks	at Var. 7633
5)	Remarks	BEI VAR. 7633

CLAAS

3

3,6 m – 4,5 m Schneidwerk

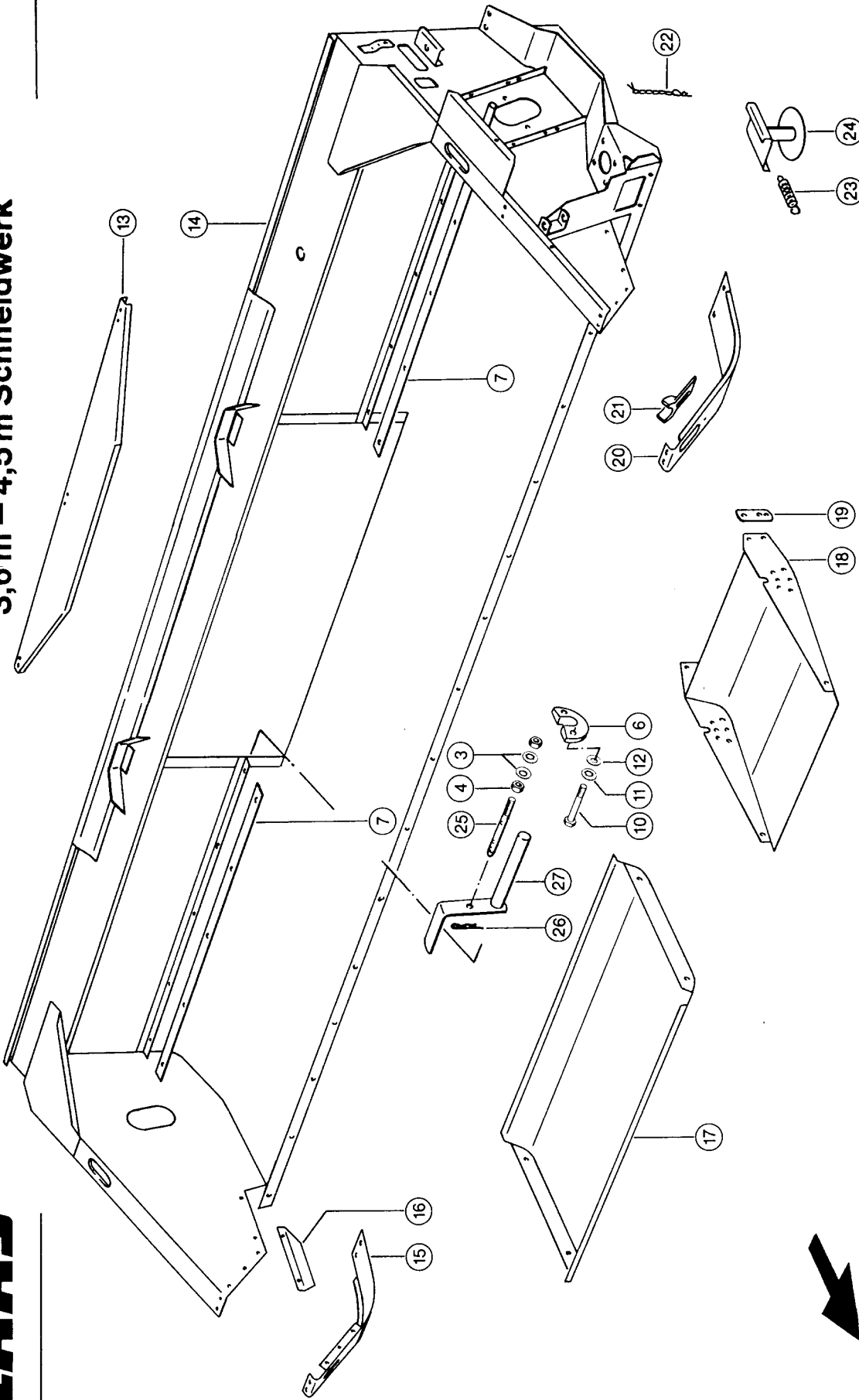

Dominator 202 MEGA

114877

CUTTERBAR DRIVE 1)

Pos.	Part No.	Description	Dimension	Quantity	Conditions
3	00 0239 389 0	CONTACT WASHER	A12	4	
4	00 0236 172 0	HEXAGONAL NUT	M12	4	
6	00 0670 156 1	GUIDE		2	
7	00 0688 053 2	STRIPPER	3X35X1017	2	2)
7	00 0670 074 2	STRIPPER	3X35X1170	2	3)
7	00 0690 497 0	STRIPPER	3X35X1322	2	4)
7	00 0670 282 2	STRIPPER	3X35X1475	2	5)
10	00 0235 563 0	HEXAGON HEAD BOLT	M12X100	2	
10	00 0237 572 0	HEXAGON HEAD BOLT	M12X35	2	
11	00 0239 389 0	CONTACT WASHER	A12	4	
12	00 0235 124 3	FLAT WASHER	12- 13X24X2,5	16	
13	00 0688 102 3	DUST SHIELD	1,5X265X1400	1	
14	00 0650 220 1	CUTTERBAR TABLE	3,60M	1	2)
14	00 0650 230 1	CUTTERBAR TABLE	3,90M	1	3)
14	00 0650 240 1	CUTTERBAR TABLE	4,20M S	1	4)
14	00 0650 110 2	CUTTERBAR TABLE	4,50M S	1	5)
15	00 0650 054 0	OUTER SHOE RH.	5X141X827	1	
16	00 0604 253 1	GUARD PLATE R.H.	1,5X124X280	1	
17	00 0673 781 4	SKID SHOE		1	
18	00 0603 902 0	SKID SHOE		2	
19	00 0603 899 1	CONNECTING PLATE	30X10X98	4	
20	00 0650 049 1	OUTER SHOE LH.	5X219,5X827	1	
21	00 0603 868 1	DIVIDER SUPPORT		2	
22	00 0673 763 0	LOCK CHAIN		2	
23	00 0942 497 0	TENSION SPRING	2,5 X 25 X 96	2	
24	00 0645 802 0	SUPPORT		2	
25	00 0615 756 0	PIN	12H9X140	2	
26	00 0673 749 0	SPRING CLIP	4,5X90	4	
27	00 0650 916 0	PLUG		2	

1) Remarks	WITH 3.6 M - 4.5 M CUTTERBAR
2) Remarks	at 3.6 m cutterbar
3) Remarks	BEI 3,9 M SCHNEIDWERK
4) Remarks	BEI 4,2 M SCHNEIDWERK
5) Remarks	BEI 4,5 M SCHNEIDWERK

CLAAS

5,1m Schneidwerk

4

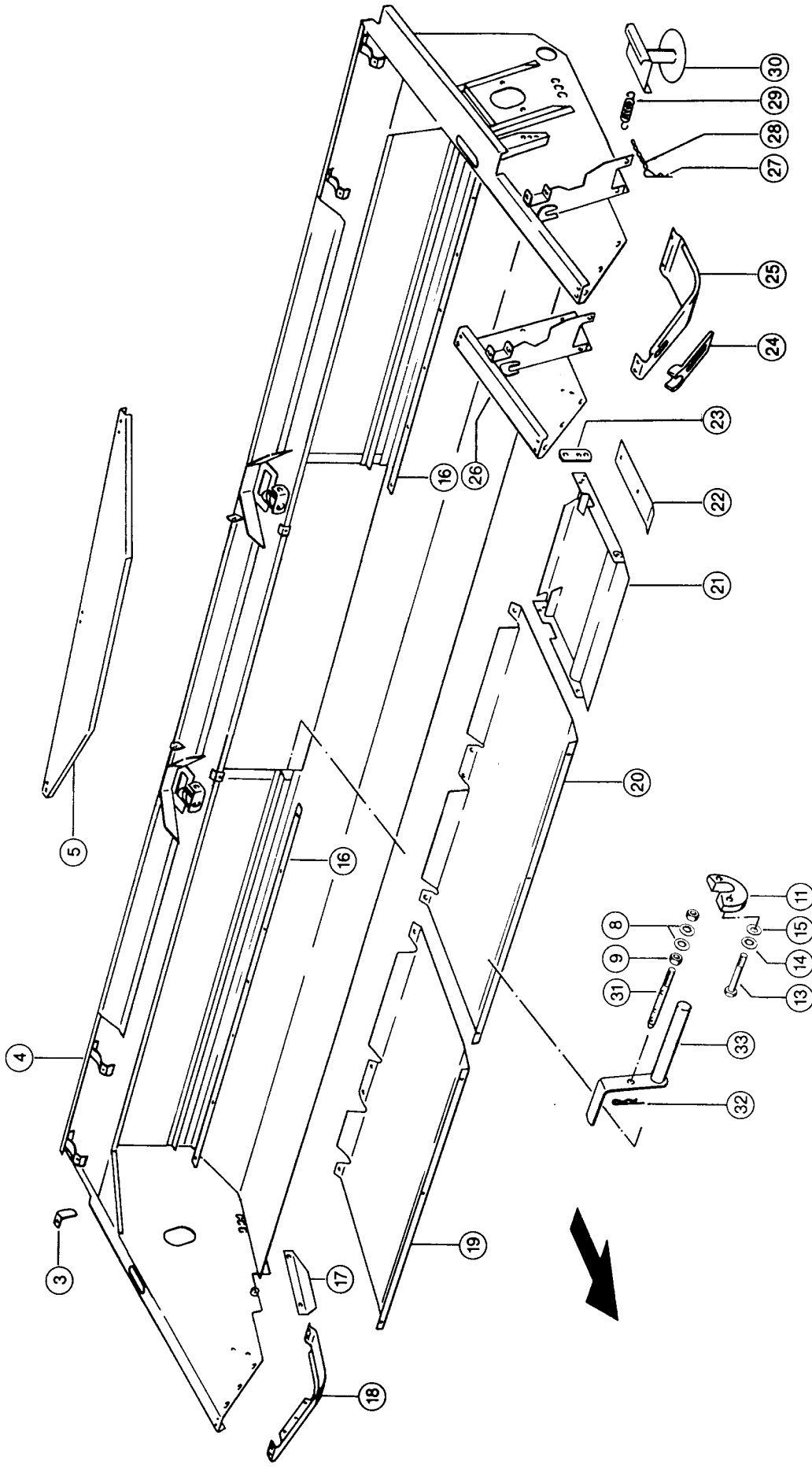

114878

Dominator 202 MEGA

CUTTERBAR DRIVE 1)

Pos.	Part No.	Description	Dimension	Quantity	Conditions
3	00 0651 428 1	ANGLE	25X5X76	1	
4	00 0650 598 5	CUTTERBAR TABLE	510 SO CA S	1	
5	00 0688 102 3	DUST SHIELD	1,5X265X1400	1	
8	00 0239 389 0	CONTACT WASHER	A12	4	
9	00 0236 172 0	HEXAGONAL NUT	M12	4	
11	00 0670 156 1	GUIDE		2	
13	00 0235 563 0	HEXAGON HEAD BOLT	M12X100	2	
13	00 0237 572 0	HEXAGON HEAD BOLT	M12X35	2	
14	00 0239 389 0	CONTACT WASHER	A12	4	
15	00 0235 124 3	FLAT WASHER	12- 13X24X2,5	16	
16	00 0674 251 2	STRIPPER	3X35X1780	2	
17	00 0604 253 1	GUARD PLATE R.H.	1,5X124X280	1	
18	00 0645 423 2	OUTER SHOE RH.		1	
19	00 0645 408 0	STONE GUARD	3X779X1814	1	
20	00 0645 407 0	STONE GUARD	3X779X1522	1	
21	00 0645 409 2	SKID SHOE		2	
23	00 0603 899 1	CONNECTING PLATE	30X10X98	4	
24	00 0603 868 1	DIVIDER SUPPORT		2	
25	00 0645 422 4	OUTER SHOE LH.	5X219,5X804	1	
27	00 0673 749 0	SPRING CLIP	4,5X90	2	
28	00 0778 096 0	KNOT CHAIN	2X 28X 3GL	2	
29	00 0942 497 0	TENSION SPRING	2,5 X 25 X 96	2	
30	00 0645 802 0	SUPPORT		2	
31	00 0615 756 0	PIN	12H9X140	2	
32	00 0673 749 0	SPRING CLIP	4,5X90	4	
33	00 0650 916 0	PLUG		2	

1) Remarks

WITH 5.1 M CUTTERBAR

CLH AS

3,6 m – 4,5 m Schneidwerk

5

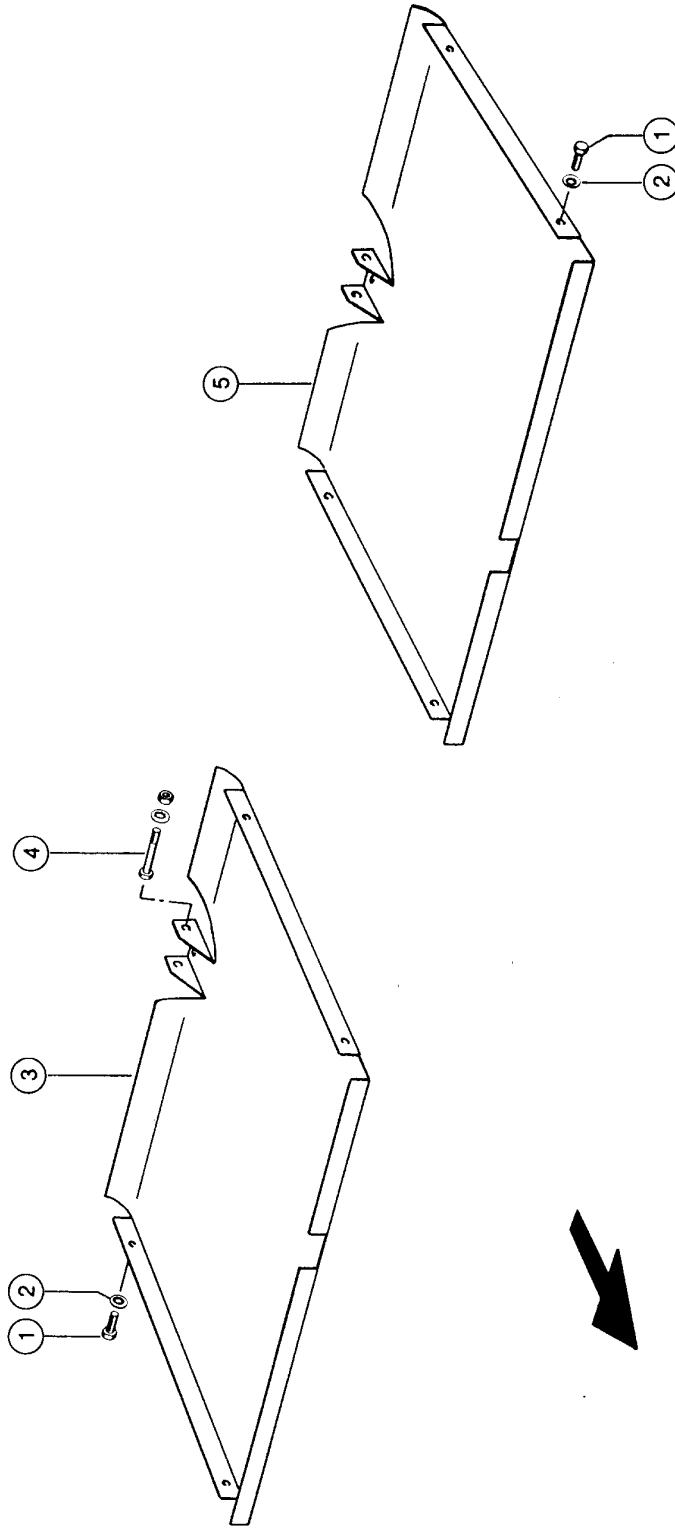

114879

Dominator 202 MEGA

STONE GUARD, VAR. 4944, 4945 1)

Pos.	Part No.	Description	Dimension	Quantity	Conditions
1	00 0237 383 0	HEXAGON HEAD BOLT	M10X25	8	
2	00 0239 388 0	CONTACT WASHER	A10-10,2X22,25X1,6	8	
3	00 0650 313 0	STONE GUARD, R.H.	661 LANG	1	2)
3	00 0650 318 0	STONE GUARD, R.H.	814 LANG	1	3)
3	00 0650 323 0	STONE GUARD, R.H.	966 LANG	1	4)
3	00 0650 328 0	STONE GUARD, R.H.	1119 LANG	1	5)
4	00 0235 223 1	HEXAGON HEAD BOLT	M10X100	2	
4	00 0236 171 0	HEXAGONAL NUT	M10	2	
4	00 0239 388 0	CONTACT WASHER	A10-10,2X22,25X1,6	2	
4	00 0236 913 2	FLAT WASHER	10-10,5X20X2	2	
5	00 0650 312 0	STONE GUARD, L.H.	661 LANG	1	2)
5	00 0650 317 0	STONE GUARD, L.H.	814 LANG	1	3)
5	00 0650 322 0	STONE GUARD, L.H.	966 LANG	1	4)
5	00 0650 327 0	STONE GUARD, L.H.	1119 LANG	1	5)

1) Remarks	WITH 3.6 M - 4.5 M CUTTERBAR OPTION
2) Remarks	at 3.6 m cutterbar
3) Remarks	BEI 3,9 M SCHNEIDWERK
4) Remarks	BEI 4,2 M SCHNEIDWERK
5) Remarks	BEI 4,5 M SCHNEIDWERK

CLAAS

3,6 m – 4,5 m Schneidwerk

6

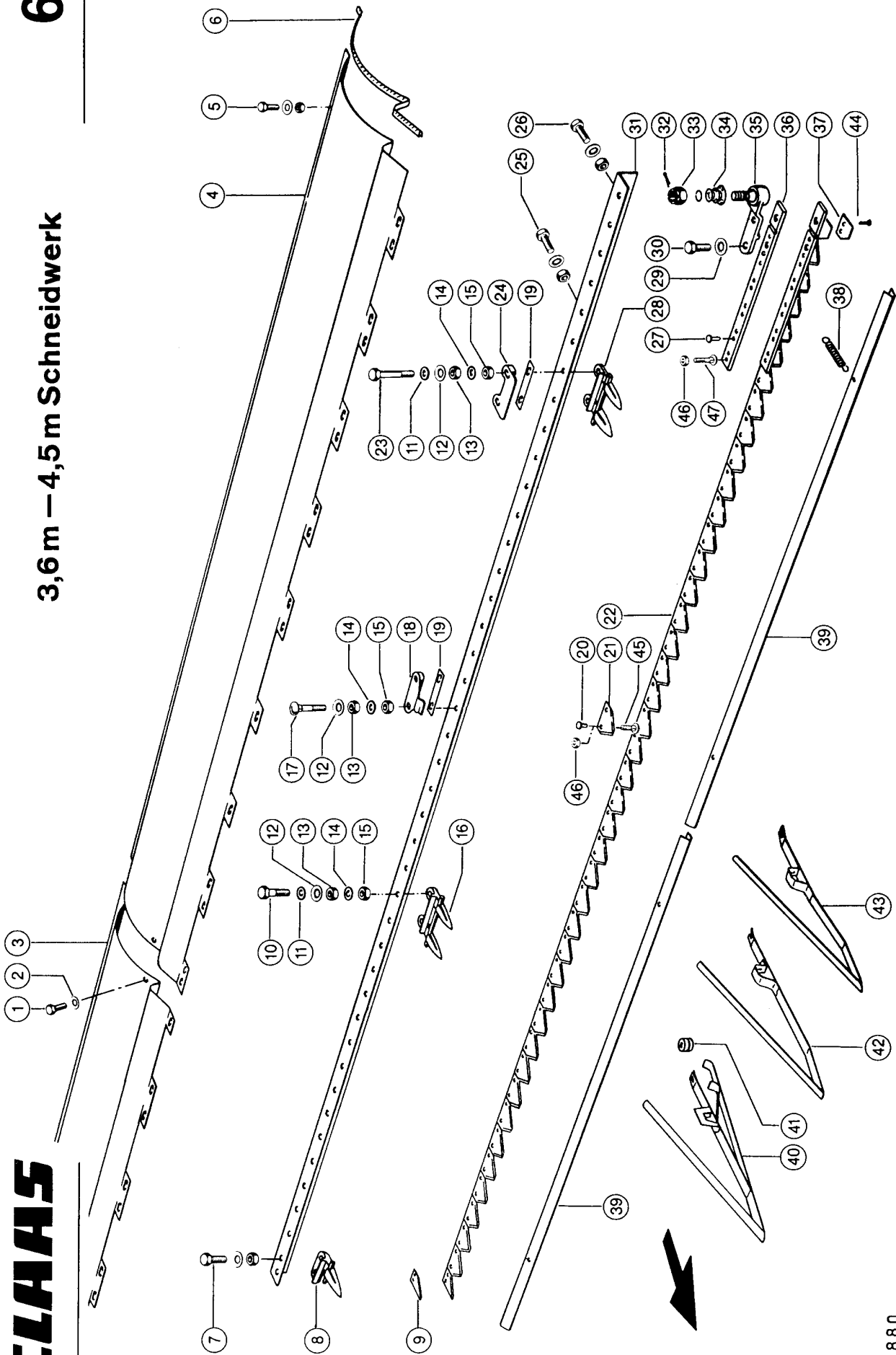

Dominator 202 MEGA

114880

CUTTER BAR 1)

Pos.	Part No.	Description	Dimension	Quantity	Conditions
1	00 0610 097 1	COACH BOLT	M8X16	2	
2	00 0239 387 0	CONTACT WASHER	A8-8,2X18X1,4	2	
3	00 0650 305 0	GUIDING PLATE	1,5X0483X1095	1	2)
3	00 0650 306 0	GUIDING PLATE	1,5X0483X1400	1	3)
3	00 0650 307 0	GUIDING PLATE	1,5X483X1705	1	4)
3	00 0650 157 0	GUIDING PLATE	1,5X483X2010	1	5)
4	00 0650 125 0	GUIDING PLATE	1,5X0483X2505	1	
5	00 0236 200 0	HEXAGON HEAD BOLT	M8X20	1	
5	00 0236 170 0	HEXAGONAL NUT	M8	1	
5	00 0239 387 0	CONTACT WASHER	A8-8,2X18X1,4	1	
6	00 0200 909 0	SEALING PROFILE	20,5X9,25X1,5	1	6)
7	00 0237 874 0	HEXAGON HEAD BOLT	M10X35	3	
7	00 0236 171 0	HEXAGONAL NUT	M10	3	
7	00 0239 388 0	CONTACT WASHER	A10-10,2X22,25X1,6	3	
8	00 0676 241 4	END FINGER		1	
9	00 0611 204 1	KNIFE SECTION		1	
9	00 0611 319 0	KNIFE SECTION PL.		1	
10	00 0235 534 1	HEXAGON HEAD BOLT	M10X50X29	25	7)
11	00 0238 292 0	WASHER	10,5X 22 X1	29	8)
12	00 0235 133 1	SPRING WASHER	10 -10,2X18,1X1,8	51	9)
13	00 0236 171 0	HEXAGONAL NUT	M10	51	9)
14	00 0236 831 0	WASHER	10,5X25X2	51	9)
15	00 0237 947 0	HEX. NUT WITH CLAMP. PART	M10	51	9)
16	00 0676 235 3	DOUBLE FINGER		22	10)
16	00 0648 406 0	DOUBLE FINGER		22	11)
17	00 0236 462 0	COACH BOLT	M10X60	22	10)
18	00 0676 236 0	PRESSURE THUMB		11	12)
18	00 0626 749 2	KNIFE CLIP		13	13)
19	00 0673 753 1	SHIM		76	14)
19	00 0688 957 0	SHIM		1	
20	00 0237 663 0	COUNTERSUNK RIVET	6X17	1	
21	00 0611 203 1	KNIFE SECTION		1	
21	00 0611 318 0	KNIFE SECTION PL.		1	
22	00 0611 229 2	MOWER KNIFE,SERRATED		1	2)
22	00 0688 070 1	MOWER KNIFE, PLAIN		1	15)
22	00 0611 222 2	MOWER KNIFE,SERRATED		1	3)
22	00 0676 306 1	MOWER KNIFE, PLAIN		1	3)
22	00 0611 022 0	MOWER KNIFE,SERRATED		1	4)
22	00 0611 213 2	MOWER KNIFE,SERRATED		1	5)
22	00 0626 727 0	MOWER KNIFE		1	16)
22	00 0676 321 1	MOWER KNIFE, PLAIN		1	17)
23	00 0237 808 0	HEXAGON HEAD BOLT	M10X75	4	
24	00 0613 017 2	KNIFE CLIP		2	
24	00 0626 748 2	KNIFE CLIP		2	13)
25	00 0237 383 0	HEXAGON HEAD BOLT	M10X25	13	18)
25	00 0236 171 0	HEXAGONAL NUT	M10	13	18)
25	00 0239 388 0	CONTACT WASHER	A10-10,2X22,25X1,6	13	18)
26	00 0237 874 0	HEXAGON HEAD BOLT	M10X35	2	
26	00 0236 171 0	HEXAGONAL NUT	M10	2	
26	00 0239 388 0	CONTACT WASHER	A10-10,2X22,25X1,6	2	
27	00 0237 054 0	COUNTERSUNK RIVET	6 X30	14	
28	00 0676 249 1	DOUBLE FINGER		4	
28	00 0648 407 0	DOUBLE FINGER		4	19)
29	00 0239 389 0	CONTACT WASHER	A12	2	

CUTTER BAR 1)

Pos.	Part No.	Description	Dimension	Quantity	Conditions
30	00 0236 056 0	HEXAGON HEAD BOLT	M12X25	2	
31	00 0688 064 1	KNIFE CUTTERBAR	50X50X3915	1	2)
31	00 0673 774 1	KNIFE CUTTERBAR	50X50X4220	1	3)
31	00 0650 273 0	KNIFE CUTTERBAR	50X50X7X4510	1	4)
31	00 0673 752 2	KNIFE CUTTERBAR	50X50X7X4815	1	5)
32	00 0235 090 0	SPLIT PIN	4 X 28	1	
33	00 0244 455 0	CASTELLATED NUT	M16X1,5	1	
34	00 0645 370 0	RUBBER CAP	D 37	1	
35	00 0100 144 0	BALL JOINT		1	
36	00 0676 231 0	CONNCETION-STEEL		1	
36	00 0626 755 0	CONNCETION-STEEL		1	13)
37	00 0616 286 0	SCRAPER BLADE		1	
38	00 0610 049 0	TENSION SPRING	2 X 16,5X 65	4	
39	00 0770 488 0	SAFETY BAR	2 X 46,5X2100	1	
39	00 0770 489 0	SAFETY BAR	2X46,5X1800	1	
39	00 0770 490 0	SAFETY BAR	2 X 46,5X2400	1	
39	00 0610 059 0	SAFETY BAR	2X46,5X3020	1	
40	00 0176 044 0	CROP LIFTER		1	20)
40	00 0176 078 0	LOCKING CLIP		1	
41	00 0176 045 0	CROP LIFTER		1	20)
42	00 0610 294 3	CROP LIFTER		1	20)
43	00 0610 272 3	CROP LIFTER		1	
44	00 0237 664 0	COUNTERSUNK RIVET	6X20	2	
45	00 0626 407 0	SERRATED BOLT		1	21)
46	00 0626 408 0	LOCK NUT		1	21)
47	00 0626 406 0	SERRATED BOLT		9	21)

1) Remarks	WITH 3.6 M - 4.5 M CUTTERBAR
2) Remarks	at 3.6 m cutterbar
3) Remarks	BEI 3,9 M SCHNEIDWERK
4) Remarks	BEI 4,2 M SCHNEIDWERK
5) Remarks	BEI 4,5 M SCHNEIDWERK
6) Remarks	500 long
7) Remarks	25, 27, 29
8) Remarks	29, 31, 33
9) Remarks	51, 55, 59
10) Remarks	22, 24, 26
11) Remarks	22, 24, 26, VERSTAERKT
12) Remarks	11, 12, 13
13) Remarks	BEI GESCHR. MESSER
14) Remarks	76, 84, 92
15) Remarks	BEI 3,6 M SCHNEIDWERK
16) Remarks	BEI 4,5 M S. W. MIT GESCHRAUBTEM MESSER
17) Remarks	BEI 4,5 M - SONDERW.
18) Remarks	13, 15, 15
19) Remarks	VERSTAERKT
20) Remarks	optional
21) Remarks	at serrated knife 64

CLAAS

5,1m Schneidwerk

7

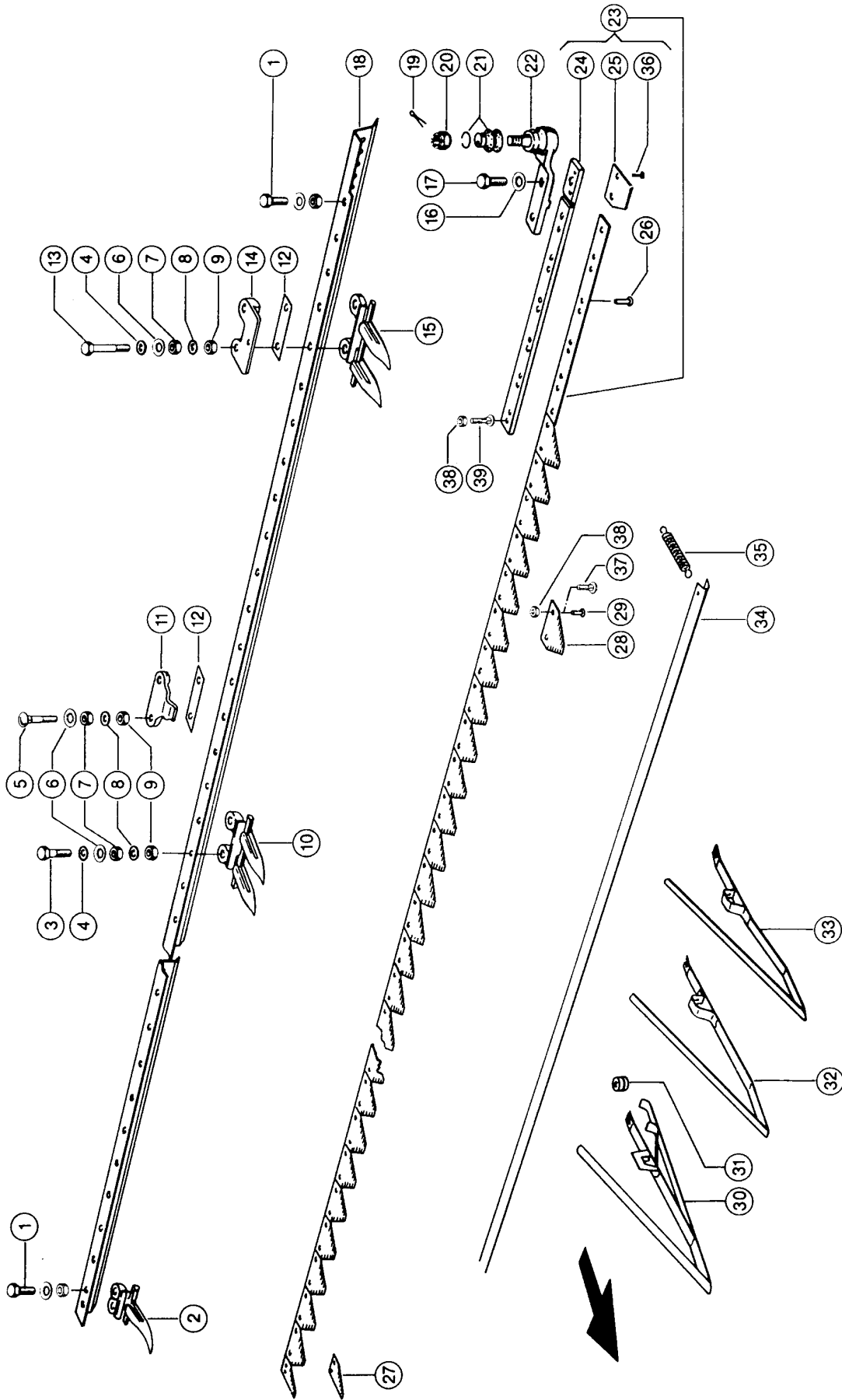

114881

Dominator 202 MEGA

CUTTER BAR 1)

Pos.	Part No.	Description	Dimension	Quantity	Conditions
1	00 0237 874 0	HEXAGON HEAD BOLT	M10X35	3	
1	00 0236 171 0	HEXAGONAL NUT	M10	3	
1	00 0239 388 0	CONTACT WASHER	A10-10,2X22,25X1,6	3	
2	00 0676 241 4	END FINGER		1	
3	00 0235 534 1	HEXAGON HEAD BOLT	M10X50X29	33	
4	00 0238 292 0	WASHER	10,5X 22 X1	37	
5	00 0236 462 0	COACH BOLT	M10X60	30	
6	00 0235 133 1	SPRING WASHER	10 -10,2X18,1X1,8	67	
7	00 0236 171 0	HEXAGONAL NUT	M10	67	
8	00 0236 831 0	WASHER	10,5X25X2	67	
9	00 0237 947 0	HEX. NUT WITH CLAMP. PART	M10	67	
10	00 0648 406 0	DOUBLE FINGER		30	
11	00 0676 236 0	PRESSURE THUMB		15	
11	00 0626 749 2	KNIFE CLIP		15	2)
12	00 0673 753 1	SHIM		100	
12	00 0688 957 0	SHIM		1	
13	00 0237 808 0	HEXAGON HEAD BOLT	M10X75	4	
14	00 0613 017 2	KNIFE CLIP		2	
14	00 0626 748 2	KNIFE CLIP		2	2)
15	00 0648 407 0	DOUBLE FINGER		4	
16	00 0239 389 0	CONTACT WASHER	A12	2	
17	00 0236 056 0	HEXAGON HEAD BOLT	M12X25	2	
18	00 0638 701 0	KNIFE CUTTERBAR	5425 LG	1	
19	00 0235 090 0	SPLIT PIN	4 X 28	1	
20	00 0244 455 0	CASTELLATED NUT	M16X1,5	1	
21	00 0645 370 0	RUBBER CAP	D 37	1	
22	00 0100 144 0	BALL JOINT		1	
23	00 0611 214 2	MOWER KNIFE,SERRATED		1	
23	00 0626 728 0	MOWER KNIFE		1	2)
23	00 0676 322 1	MOWER KNIFE, PLAIN		1	3)
24	00 0676 231 0	CONNCETION-STEEL		1	
24	00 0626 755 0	CONNCETION-STEEL		1	2)
25	00 0616 286 0	SCRAPER BLADE		1	
26	00 0237 054 0	COUNTERSUNK RIVET	6 X30	14	
27	00 0611 204 1	KNIFE SECTION		1	
27	00 0611 319 0	KNIFE SECTION PL.		1	
28	00 0611 203 1	KNIFE SECTION		68	
28	00 0611 318 0	KNIFE SECTION PL.		68	
29	00 0237 663 0	COUNTERSUNK RIVET	6X17	1	
30	00 0176 044 0	CROP LIFTER		1	4)
30	00 0176 078 0	LOCKING CLIP		1	3)
31	00 0176 045 0	CROP LIFTER		1	4)
32	00 0610 294 3	CROP LIFTER		1	4)
33	00 0610 272 3	CROP LIFTER		15	
34	00 0610 059 0	SAFETY BAR	2X46,5X3020	1	
34	00 0770 488 0	SAFETY BAR	2 X 46,5X2100	1	
35	00 0610 049 0	TENSION SPRING	2 X 16,5X 65	4	
36	00 0237 664 0	COUNTERSUNK RIVET	6X20	2	
37	00 0626 407 0	SERRATED BOLT		1	5)
38	00 0626 408 0	LOCK NUT		1	5)
39	00 0626 406 0	SERRATED BOLT		9	5)

1) Remarks

WITH 5.1 M CUTTERBAR

CUTTER BAR 1)

2) Remarks	BEI GESCHR. MESSER
3) Remarks	SONDERWUNSCH
4) Remarks	optional
5) Remarks	at serrated knife 64

CLAAS

5,1m Schneidwerk

8

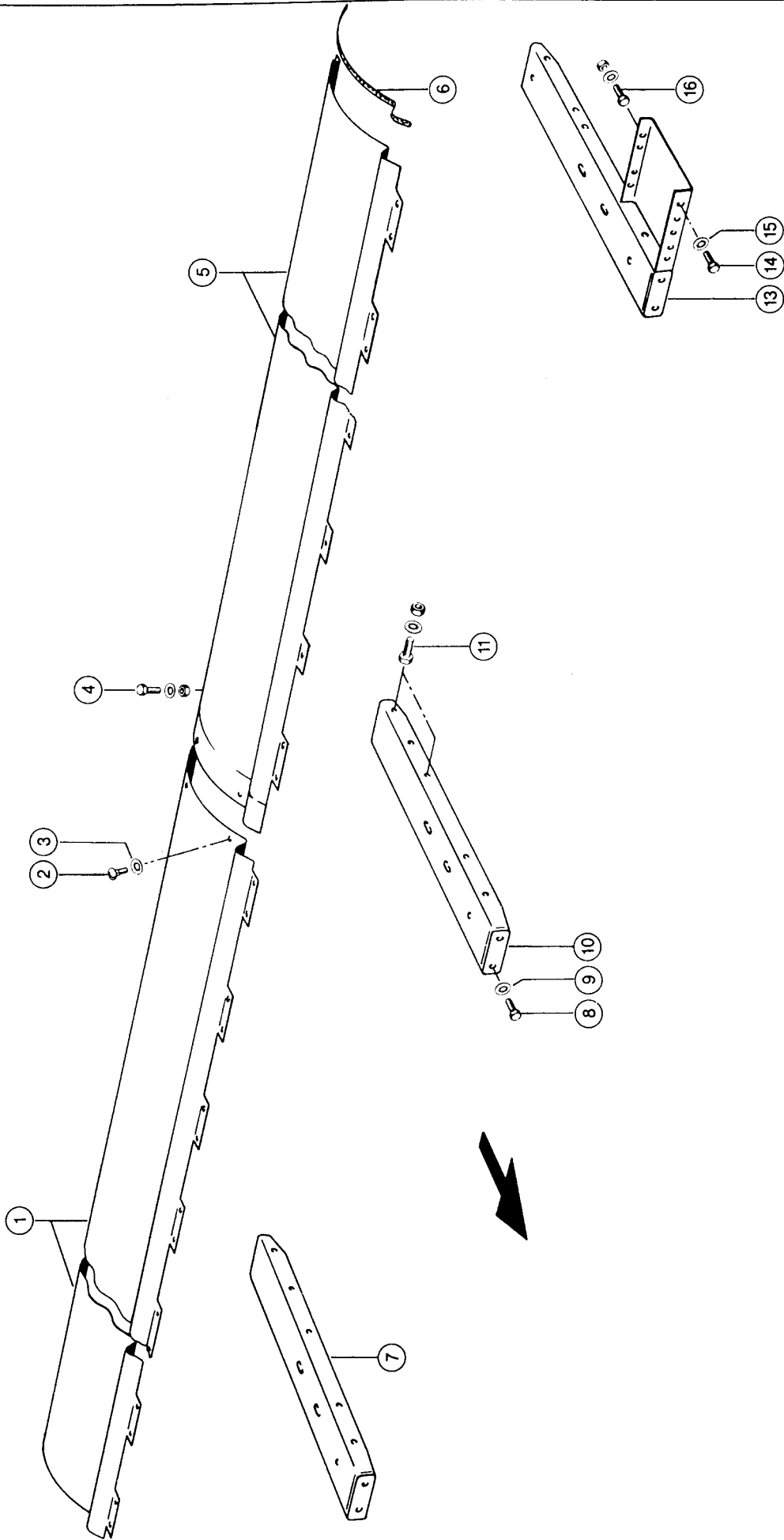

114882

Dominator 202 MEGA

CUTTERBAR DRIVE 1)

Pos.	Part No.	Description	Dimension	Quantity	Conditions
1	00 0650 095 0	GUIDING PLATE	1,5X483X2620	1	
2	00 0610 097 1	COACH BOLT	M8X16	2	
3	00 0239 393 1	CONTACT WASHER	B 8 -8.2X22X1,9	2	
4	00 0236 200 0	HEXAGON HEAD BOLT	M8X20	14	
4	00 0236 170 0	HEXAGONAL NUT	M8	14	
4	00 0239 387 0	CONTACT WASHER	A8-8,2X18X1,4	28	
5	00 0650 125 0	GUIDING PLATE	1,5X0483X2505	1	
6	00 0200 909 0	SEALING PROFILE	20,5X9,25X1,5	1	2)
7	00 0645 388 1	SUPPORT		1	
8	00 0237 382 0	HEXAGON HEAD BOLT	M10X20	18	
9	00 0239 388 0	CONTACT WASHER	A10-10,2X22,25X1,6	18	
10	00 0645 388 1	SUPPORT		6	
11	00 0236 056 0	HEXAGON HEAD BOLT	M12X25	32	
11	00 0236 172 0	HEXAGONAL NUT	M12	32	
11	00 0239 389 0	CONTACT WASHER	A12	32	
13	00 0638 707 1	SUPPORT L.H.		1	
14	00 0239 049 0	HEXAGON HEAD BOLT	M12X30-MKL	5	
15	00 0239 389 0	CONTACT WASHER	A12	5	
16	00 0237 382 0	HEXAGON HEAD BOLT	M10X20	4	
16	00 0236 171 0	HEXAGONAL NUT	M10	4	
16	00 0239 388 0	CONTACT WASHER	A10-10,2X22,25X1,6	4	
1)	Remarks	WITH 5.1 M CUTTERBAR			
2)	Remarks	483 long			

CLAAS

3,6 m – 5,1 m Schneidwerk

9

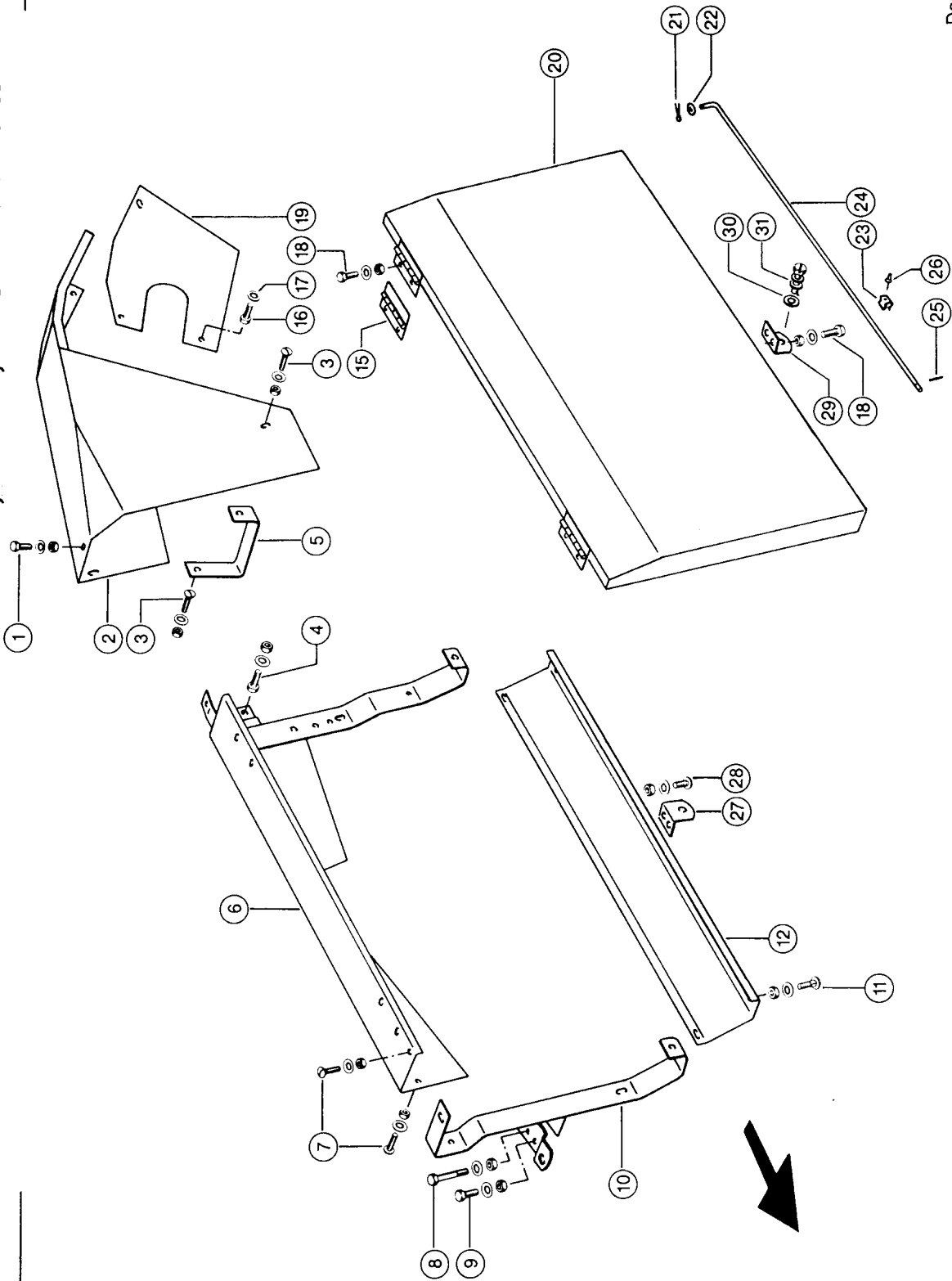

Dominator 202 MEGA

114883

GUARDS 1)

Pos.	Part No.	Description	Dimension	Quantity	Conditions
1	00 0244 138 0	HEXAGON HEAD BOLT	M 8X18	1	
1	00 0236 170 0	HEXAGONAL NUT	M8	1	
1	00 0239 387 0	CONTACT WASHER	A8-8,2X18X1,4	1	
2	00 0614 986 0	GUARD PLATE REAR		1	
3	00 0610 097 1	COACH BOLT	M8X16	2	
3	00 0236 170 0	HEXAGONAL NUT	M8	2	
3	00 0239 387 0	CONTACT WASHER	A8-8,2X18X1,4	2	
4	00 0237 570 0	HEXAGON HEAD BOLT	M10X16	1	
4	00 0236 171 0	HEXAGONAL NUT	M10	1	
4	00 0239 388 0	CONTACT WASHER	A10-10,2X22,25X1,6	1	
5	00 0728 132 1	SUPPORT	40X5X307	1	
6	00 0614 954 1	BACK PANEL L.H.		1	
7	00 0610 097 1	COACH BOLT	M8X16	2	
7	00 0236 170 0	HEXAGONAL NUT	M8	2	
7	00 0239 387 0	CONTACT WASHER	A8-8,2X18X1,4	2	
8	00 0235 542 0	HEXAGON HEAD BOLT	M10X90	1	
8	00 0235 541 0	HEXAGON HEAD BOLT	M10X85	1	2)
8	00 0236 171 0	HEXAGONAL NUT	M10	1	
8	00 0239 388 0	CONTACT WASHER	A10-10,2X22,25X1,6	1	
9	00 0237 383 0	HEXAGON HEAD BOLT	M10X25	1	
9	00 0236 171 0	HEXAGONAL NUT	M10	1	
9	00 0239 388 0	CONTACT WASHER	A10-10,2X22,25X1,6	1	
10	00 0614 955 0	SUPPORT FRONT		1	
11	00 0665 564 1	COACH BOLT	M6X12	4	
11	00 0236 169 0	HEXAGONAL NUT	M6	4	
11	00 0239 386 0	CONTACT WASHER	A 6	4	
12	00 0645 429 3	SKID	0,75X208X994	1	
15	00 0654 313 0	HINGE	1.9X50X101	2	
16	00 0237 465 0	HEXAGON HEAD BOLT	M6X16	2	
17	00 0239 386 0	CONTACT WASHER	A 6	2	
18	00 0237 464 0	HEXAGON HEAD BOLT	M06X12	6	
18	00 0236 169 0	HEXAGONAL NUT	M6	6	
18	00 0239 386 0	CONTACT WASHER	A 6	6	
19	00 0614 959 0	COVER PLATE		1	
20	00 0614 953 1	DOOR, FRONT		1	
21	00 0235 110 0	SPLIT PIN	2X18	1	
22	00 0236 912 2	FLAT WASHER	8 - 8,4X16X1,6	1	
23	00 0652 433 0	CLAMP SPRING	12X18X15X0,75	1	
24	00 0674 377 0	SUPPORT	D7,75X817	1	
25	00 0237 783 0	SPRING PIN	3 X 16	1	
26	00 0237 812 1	BLIND RIVET	A 4,0X 8 - SCHERFEST.244	1	
27	00 0615 538 0	ANGLE		1	
28	00 0610 097 1	COACH BOLT	M8X16	2	
28	00 0236 170 0	HEXAGONAL NUT	M8	2	
28	00 0239 387 0	CONTACT WASHER	A8-8,2X18X1,4	2	
29	00 0615 541 0	ANGLE	2X50X60	1	
30	00 0601 243 0	SUPPORTING WASHER	10,8X25X0,6	1	
31	00 0601 608 0	LOCK TRUNNION	4,69-5,45 KL-L	1	

1) Remarks

WITH 3.6 M - 5.1 M CUTTERBAR

2) Remarks

BEI 5,1 M SCHNEIDWERK

CLAAS

10

3,6m – 5,1m Schneidwerk

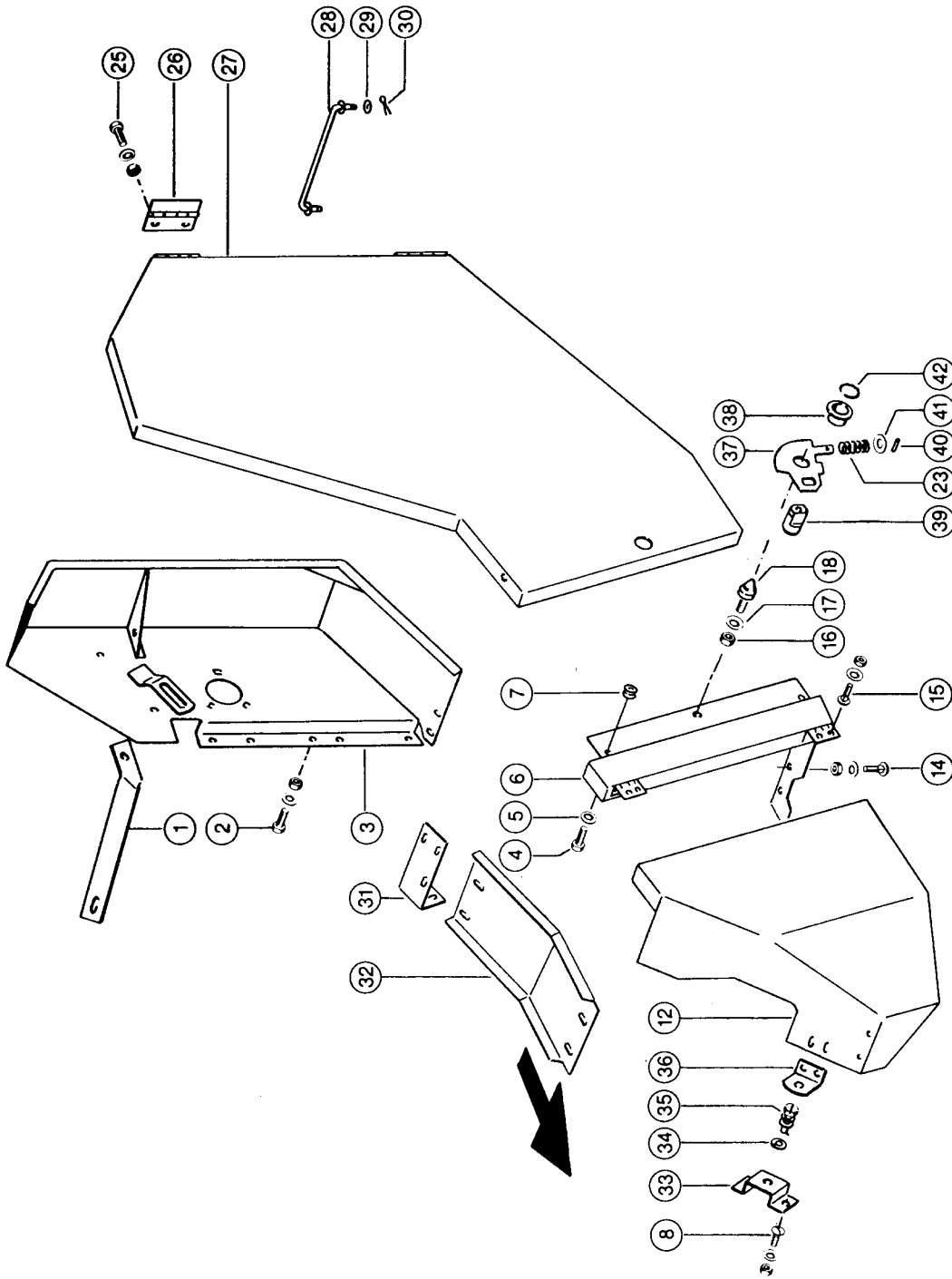

Dominator 202 MEGA

114884

Thank you so much for reading.
Please click the “Buy Now!”
button below to download the
complete manual.



After you pay.

You can download the most
perfect and complete manual in
the world immediately.

Our support email:

ebooklibonline@outlook.com