

7

CLAAS

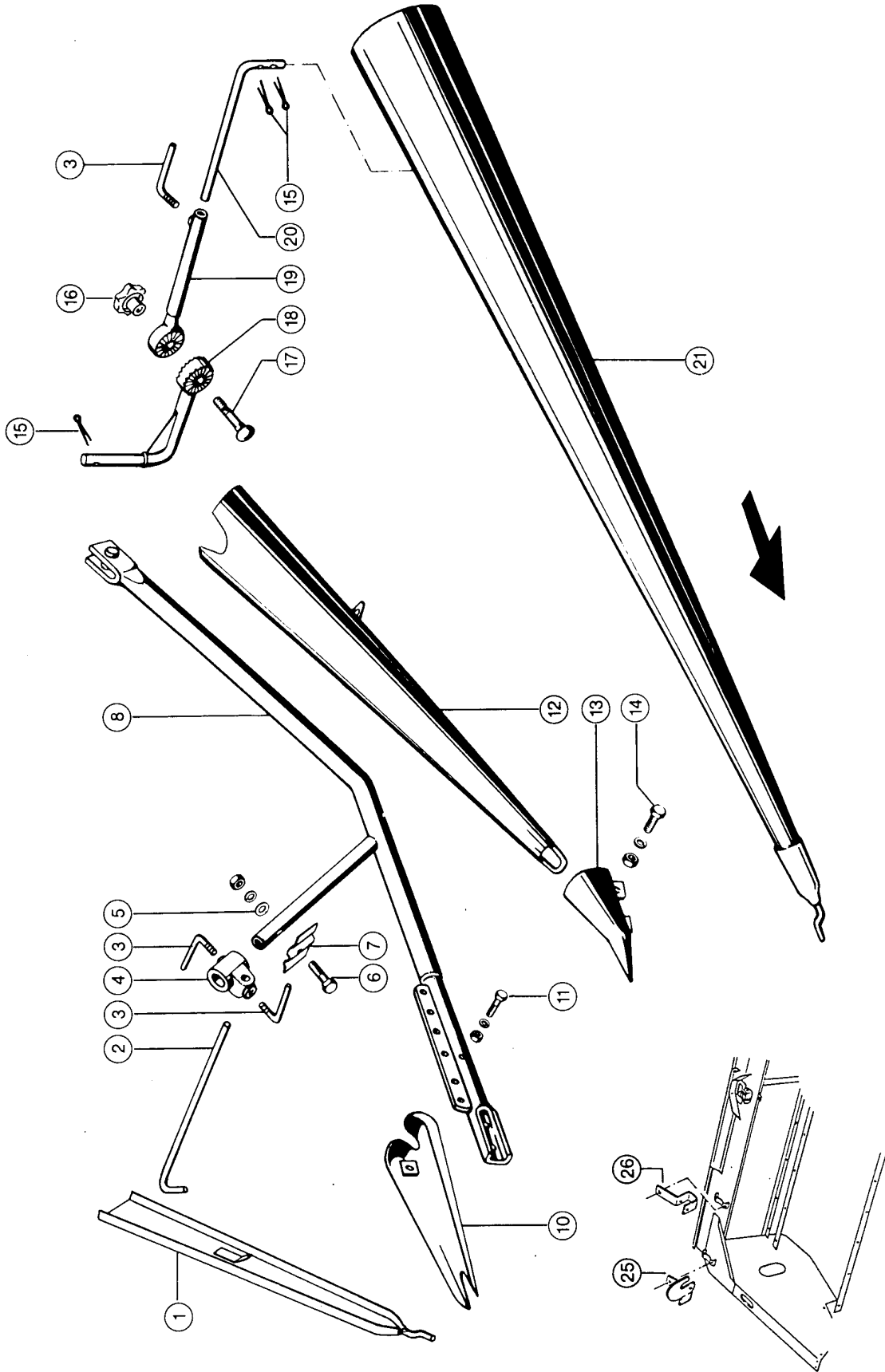

Dominator 218 / 208 MEGA

114054

DIVIDER, 12 / 10, 20 1)

Pos.	Part No.	Description	Dimension	Quantity	Conditions
1	00 0612 558 1	INT.DIVIDER LONG	870 LANG	2	2)
1	00 0612 579 0	INT.DIVIDER SHORT	600 LANG	2	3)
2	00 0616 214 1	ADJUSTING ROD	D 12X490	2	
3	00 0500 924 2	TOMMY SCREW	M 12	6	
4	00 0609 887 0	CROSS BEARING		2	
5	00 0236 913 2	FLAT WASHER	10-10,5X20X2	4	
6	00 0235 533 0	HEX.HEAD BOLT	M10X45	4	
6	00 0236 171 0	HEXAGONAL NUT	M10	4	
6	00 0239 388 0	CONTACT WASHER	A10-10,2X22,25X1,6	4	
7	00 0609 888 1	INTERMED.PIECE	1,5X37X58	4	
8	00 0609 893 1	DIVIDER SUPP.TUBE	1800 LG	2	2)
8	00 0609 867 1	DIVIDER SUPP.TUBE	1540 LG	2	3)
10	00 0610 236 1	GLIDE SKID	320X115X50	2	
11	00 0235 519 0	HEXAGON HEAD BOLT	M 8X50	2	
11	00 0236 170 0	HEXAGONAL NUT	M8	2	
11	00 0239 387 0	CONTACT WASHER	A8-8,2X18X1,4	2	
12	00 0674 389 4	DIVIDER CEN.PLATE	1000 LANG	2	2)
12	00 0670 372 3	DIVIDER CEN.PLATE	840 LANG	2	3)
13	00 0520 020 1	POINT	230X105X90	2	
14	00 0237 383 0	HEXAGON HEAD BOLT	M10X25	4	
14	00 0236 171 0	HEXAGONAL NUT	M10	4	
14	00 0239 388 0	CONTACT WASHER	A10-10,2X22,25X1,6	4	
15	00 0235 097 0	SPLIT PIN	5X36	6	
16	00 0504 504 0	HANDLE	N 100	1	4)
16	00 0238 056 0	CONTROL KNOB	K 63-M12	1	5)
16	00 0238 056 0	CONTROL KNOB	K 63-M12	2	3)
17	00 0238 913 0	COACH BOLT	M12X 60	1	4)
17	00 0211 180 1	COACH BOLT	M12X 55	1	5)
17	00 0211 180 1	COACH BOLT	M12X 55	2	3)
18	00 0609 873 0	ADJUSTING PLATE		2	
19	00 0609 861 0	ADJUSTING TUBE	330 LANG	2	2)
19	00 0609 861 0	ADJUSTING TUBE	330 LANG	2	3)
20	00 0610 579 0	SUPPORT	D20X312	2	
21	00 0612 583 2	OUTER DIVIDER	2100 LANG	2	2)
21	00 0612 583 2	OUTER DIVIDER	2100 LANG	2	3)
25	00 0707 859 1	SUPPORT	RECHTS	1	6)
25	00 0707 860 1	SUPPORT	LINKS	1	7)
26	00 0707 857 1	SUPPORT	30X6X255,5	2	

1) Remarks 12 / 10 = Long Divider
12 / 20 = Short Divider

2) Remarks 12 / 10

3) Remarks 12 / 20

4) Remarks 12 / 10 right hand side

5) Remarks 12 / 10 left hand side

6) Remarks left

7) Remarks right

2

Dominator 218 / 208 MEGA

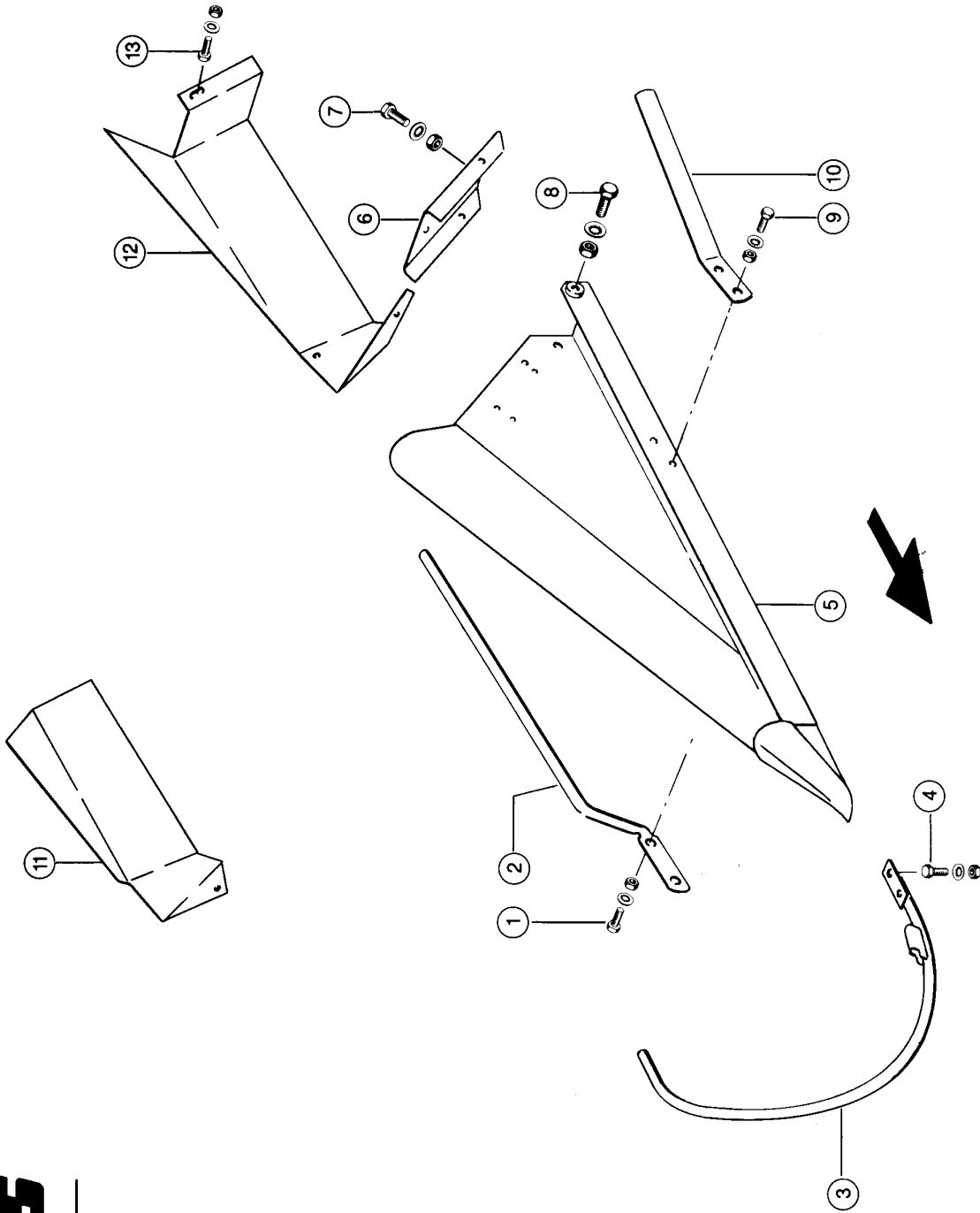

CLAAS

114055

SPECIAL CROP DIVIDER, VAR. 4282, 7633, 1)

Pos.	Part No.	Description	Dimension	Quantity	Conditions
1	00 0234 953 0	COACH BOLT	M8X20X13	4	
1	00 0236 170 0	HEXAGONAL NUT	M8	4	
1	00 0239 387 0	CONTACT WASHER	A8-8,2X18X1,4	4	
2	00 0688 975 1	DEFLECTOR INNER		2	2)
3	00 0688 025 0	BEND DIVIDER		2	3)
4	00 0237 442 0	HEXAGON HEAD BOLT	M8X25	4	
4	00 0236 170 0	HEXAGONAL NUT	M8	4	
4	00 0239 387 0	CONTACT WASHER	A8-8,2X18X1,4	4	
5	00 0688 969 1	DIVIDER L.H.		1	
5	00 0688 970 1	DIVIDER R.H.		1	
6	00 0688 974 1	SUPPORT	4X161X200	2	
7	00 0237 423 0	HEXAGON HEAD BOLT	M10X28	4	
7	00 0236 171 0	HEXAGONAL NUT	M10	4	
7	00 0239 388 0	CONTACT WASHER	A10-10,2X22,25X1,6	4	
8	00 0236 056 0	HEXAGON HEAD BOLT	M12X25	4	
8	00 0236 172 0	HEXAGONAL NUT	M12	4	
8	00 0239 389 0	CONTACT WASHER	A12	4	
9	00 0237 439 0	HEXAGON HEAD BOLT	M8X16	4	
9	00 0236 170 0	HEXAGONAL NUT	M8	4	
9	00 0239 387 0	CONTACT WASHER	A8-8,2X18X1,4	4	
10	00 0688 976 0	DEFLECTOR OUTER	3,0X0030X0400	2	
11	00 0670 069 1	DEFLECTOR R.H.	1,5X278,5X600	1	
12	00 0670 070 1	DEFLECTOR L.H.	1,5X0280X0600	1	
13	00 0237 439 0	HEXAGON HEAD BOLT	M8X16	2	
13	00 0236 170 0	HEXAGONAL NUT	M8	2	
13	00 0239 387 0	CONTACT WASHER	A8-8,2X18X1,4	4	

1) Remarks	optional
2) Remarks	at Var. 7195
3) Remarks	at Var. 7633

3

4,5 m Schneidwerk

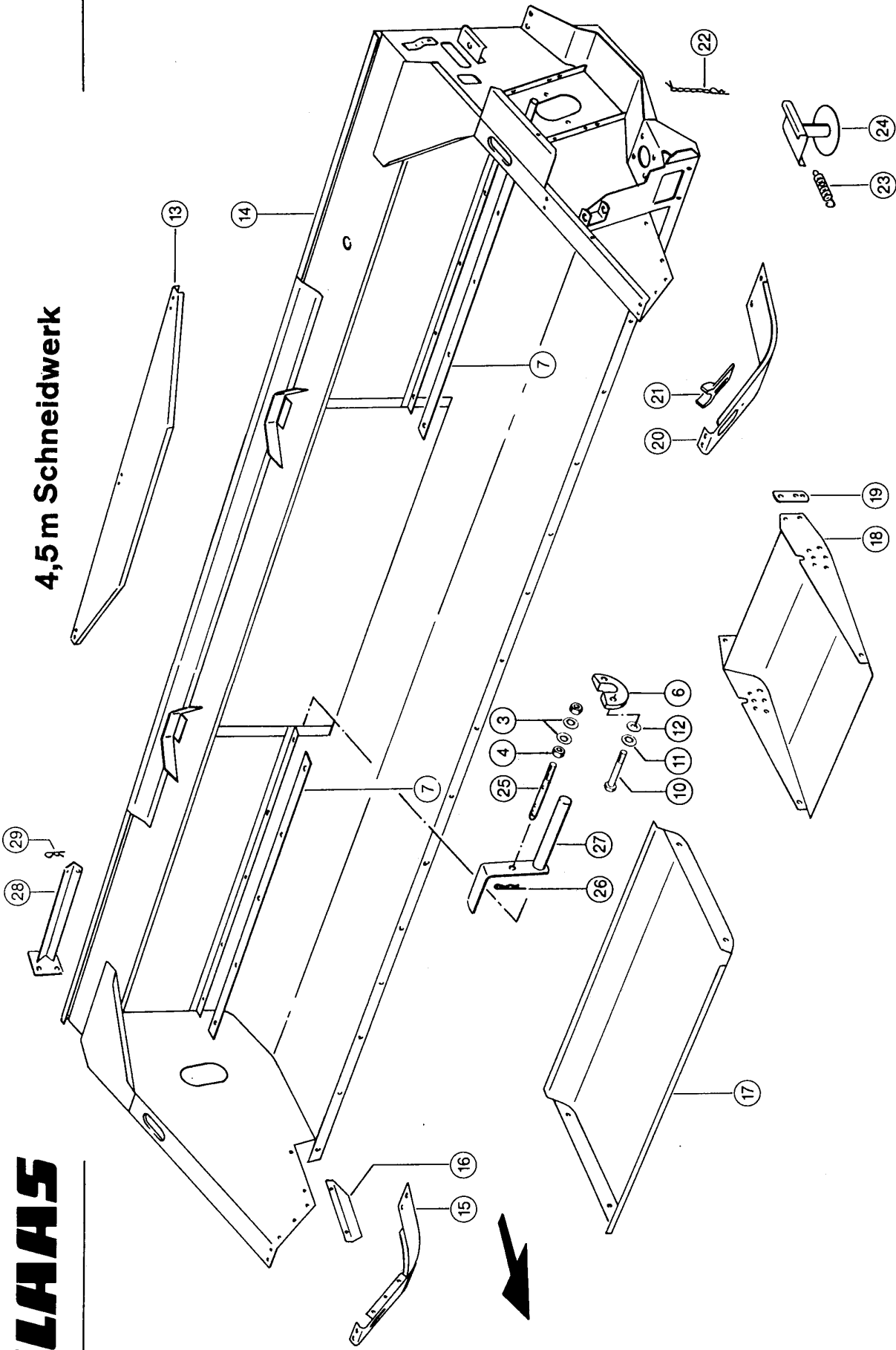

Dominator 218 / 208 MEGA

CLAAS

114056

CUTTERBAR DRIVE 1)

Pos.	Part No.	Description	Dimension	Quantity	Conditions
3	00 0239 389 0	CONTACT WASHER	A12	4	
4	00 0236 172 0	HEXAGONAL NUT	M12	4	
6	00 0670 156 1	GUIDE		2	
7	00 0670 282 2	STRIPPER	3X35X1475	2	
10	00 0235 563 0	HEXAGON HEAD BOLT	M12X100	2	
10	00 0237 572 0	HEXAGON HEAD BOLT	M12X35	2	
11	00 0239 389 0	CONTACT WASHER	A12	4	
12	00 0235 124 3	FLAT WASHER	12- 13X24X2,5	16	
13	00 0688 102 3	DUST SHIELD	1,5X265X1400	1	
14	00 0650 110 2	CUTTERBAR TABLE	4,50M S	1	
15	00 0650 054 0	OUTER SHOE RH.	5X141X827	1	
16	00 0604 253 1	GUARD PLATE R.H.	1,5X124X280	1	
17	00 0673 781 4	SKID SHOE		1	
18	00 0603 902 0	SKID SHOE		2	
19	00 0603 899 1	CONNECTING PLATE	30X10X98	4	
20	00 0650 049 1	OUTER SHOE LH.	5X219,5X827	1	
21	00 0603 868 1	DIVIDER SUPPORT		2	
22	00 0673 763 0	LOCK CHAIN		2	
23	00 0942 497 0	TENSION SPRING	2,5 X 25 X 96	2	
24	00 0645 802 0	SUPPORT		2	
25	00 0615 756 0	PIN	12H9X140	2	
26	00 0673 749 0	SPRING CLIP	4,5X90	4	
27	00 0650 916 0	PLUG		2	
28	00 0707 865 1	SUPPORT		1	2)
29	00 0665 666 0	SPRING CLIP	3X90	2	2)

1) Remarks at 4.5 m cutterbar

2) Remarks from cutterbar No. 702 004 11

CLAAS

5,1m Schneidwerk

4

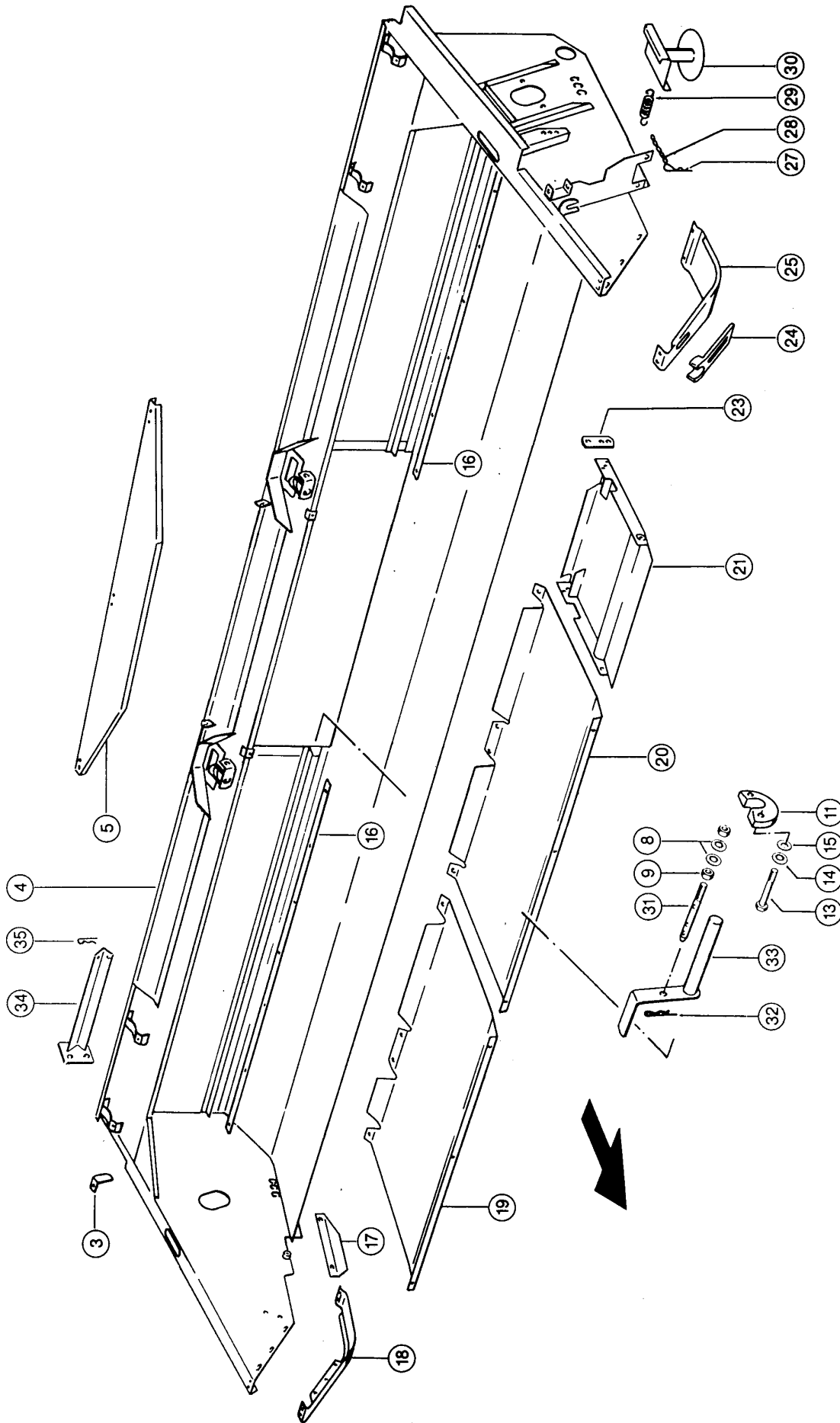

Dominator 218 / 208 MEGA

114057

CUTTERBAR DRIVE 1)

Pos.	Part No.	Description	Dimension	Quantity	Conditions
3	00 0651 428 1	ANGLE	25X5X76	1	
4	00 0650 598 5	CUTTERBAR TABLE	510 SO CA S	1	
5	00 0688 102 3	DUST SHIELD	1,5X265X1400	1	
8	00 0239 389 0	CONTACT WASHER	A12	4	
9	00 0236 172 0	HEXAGONAL NUT	M12	4	
11	00 0670 156 1	GUIDE		2	
13	00 0235 563 0	HEXAGON HEAD BOLT	M12X100	2	
13	00 0237 572 0	HEXAGON HEAD BOLT	M12X35	2	
14	00 0239 389 0	CONTACT WASHER	A12	4	
15	00 0235 124 3	FLAT WASHER	12- 13X24X2,5	16	
16	00 0674 251 2	STRIPPER	3X35X1780	2	
17	00 0604 253 1	GUARD PLATE R.H.	1,5X124X280	1	
18	00 0645 423 2	OUTER SHOE RH.		1	
19	00 0614 738 0	STONE GUARD	3,0X0779X1794	1	
20	00 0614 736 0	STONE GUARD	3X779X1522	1	
21	00 0645 409 2	SKID SHOE		2	
23	00 0603 899 1	CONNECTING PLATE	30X10X98	4	
24	00 0603 868 1	DIVIDER SUPPORT		2	
25	00 0645 422 4	OUTER SHOE LH.	5X219,5X804	1	
27	00 0673 749 0	SPRING CLIP	4,5X90	2	
28	00 0778 096 0	KNOT CHAIN	2X 28X 3GL	2	
29	00 0942 497 0	TENSION SPRING	2,5 X 25 X 96	2	
30	00 0645 802 0	SUPPORT		2	
31	00 0615 756 0	PIN	12H9X140	2	
32	00 0673 749 0	SPRING CLIP	4,5X90	4	
33	00 0650 916 0	PLUG		2	
34	00 0707 865 1	SUPPORT		1	2)
35	00 0665 666 0	SPRING CLIP	3X90	1	2)

1) Remarks at 5.1 m cutterbar

2) Remarks from cutterbar No. 702 004 11

CLAAS

4,5 m Schneidwerk

5

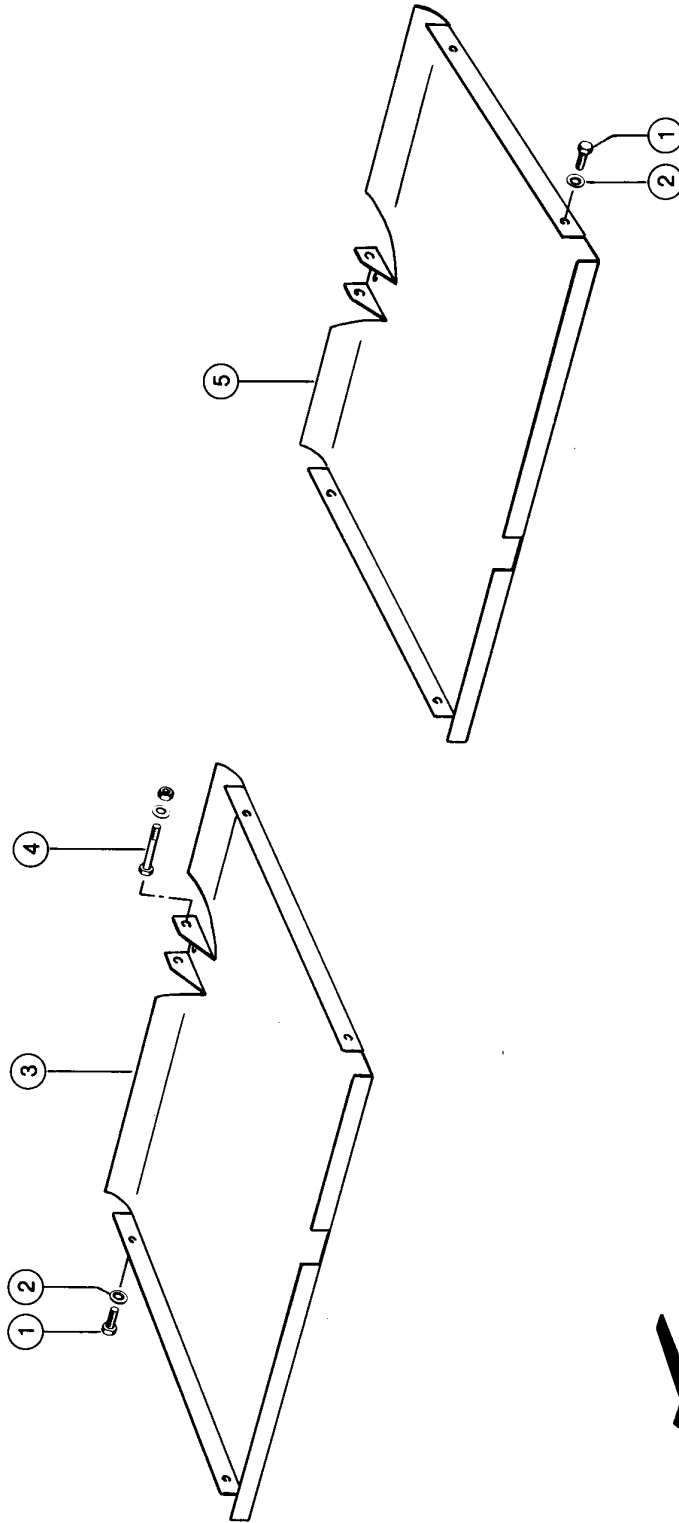

114058

Dominator 218 / 208 MEGA

STONE GUARD, 7 / 11 1)

Pos.	Part No.	Description	Dimension	Quantity	Conditions
1	00 0237 383 0	HEXAGON HEAD BOLT	M10X25	8	
2	00 0239 388 0	CONTACT WASHER	A10-10,2X22,25X1,6	8	
3	00 0650 328 0	STONE GUARD, R.H.	1119 LANG	1	
4	00 0235 223 1	HEXAGON HEAD BOLT	M10X100	2	
4	00 0236 171 0	HEXAGONAL NUT	M10	2	
4	00 0239 388 0	CONTACT WASHER	A10-10,2X22,25X1,6	2	
4	00 0236 913 2	FLAT WASHER	10-10,5X20X2	2	
5	00 0650 327 0	STONE GUARD, L.H.	1119 LANG	1	
1)	Remarks	With 4.5 m Cutterbar Option			

6

4,5 m Schneidwerk

CLAAS

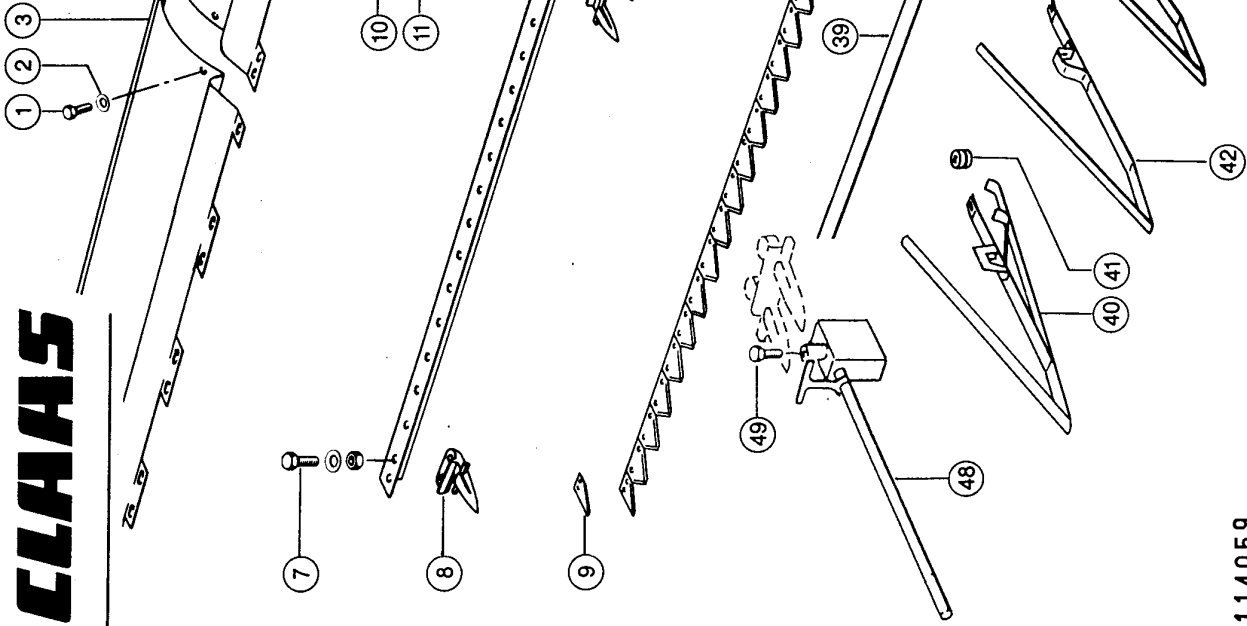

Dominator 218 / 208 MEGA

114059

CUTTER BAR 1)

Pos.	Part No.	Description	Dimension	Quantity	Conditions
1	00 0610 097 1	COACH BOLT	M8X16	2	
2	00 0239 387 0	CONTACT WASHER	A8-8,2X18X1,4	2	
3	00 0650 157 0	GUIDING PLATE	1,5X483X2010	1	
4	00 0650 125 0	GUIDING PLATE	1,5X0483X2505	1	
5	00 0236 200 0	HEXAGON HEAD BOLT	M8X20	1	
5	00 0236 170 0	HEXAGONAL NUT	M8	1	
5	00 0239 387 0	CONTACT WASHER	A8-8,2X18X1,4	1	
6	00 0200 909 0	SEALING PROFILE	20,5X9,25X1,5	1	2)
7	00 0235 530 0	HEX.HEAD BOLT	M10X30	3	3)
7	00 0237 874 0	HEXAGON HEAD BOLT	M10X35	3	4)
7	00 0236 171 0	HEXAGONAL NUT	M10	3	
7	00 0239 388 0	CONTACT WASHER	A10-10,2X22,25X1,6	3	
8	00 0676 241 4	END FINGER		1	
8	00 0626 296 3	END FINGER		1	5)
9	00 0611 204 1	KNIFE SECTION		1	
9	00 0611 319 0	KNIFE SECTION PL.		1	
10	00 0235 534 1	HEXAGON HEAD BOLT	M10X50X29	31	6)
11	00 0238 292 0	WASHER	10,5X 22 X1	33	
12	00 0235 133 1	SPRING WASHER	10 -10,2X18,1X1,8	59	
13	00 0236 171 0	HEXAGONAL NUT	M10	59	
14	00 0236 831 0	WASHER	10,5X25X2	59	
15	00 0237 947 0	HEX. NUT WITH CLAMP. PART	M10	59	
16	00 0676 235 3	DOUBLE FINGER		26	
16	00 0626 295 1	DOUBLE FINGER		26	5)
17	00 0236 462 0	COACH BOLT	M10X60	26	
18	00 0626 749 1	KNIFE CLIP		13	3)
18	00 0676 236 0	PRESSURE THUMB		13	4)
18	00 0626 749 1	KNIFE CLIP		13	7)
19	00 0688 957 0	SHIM		1	
19	00 0673 753 1	SHIM		1	
20	00 0237 663 0	COUNTERSUNK RIVET	6X17	1	
21	00 0611 203 1	KNIFE SECTION		1	
21	00 0611 318 0	KNIFE SECTION PL.		1	
22	00 0611 213 3	MOWER KNIFE		1	
22	00 0626 727 0	MOWER KNIFE		1	7)
22	00 0676 321 1	MOWER KNIFE, PLAIN		1	8)
23	00 0236 464 0	COACH BOLT	M10X 70	2	9)
23	00 0237 808 0	HEXAGON HEAD BOLT	M10X75	4	10)
24	00 0626 748 1	KNIFE CLIP		1	9)
24	00 0613 017 2	KNIFE CLIP		2	10)
24	00 0626 748 1	KNIFE CLIP		1	7)
25	00 0237 383 0	HEXAGON HEAD BOLT	M10X25	15	
25	00 0236 171 0	HEXAGONAL NUT	M10	15	
25	00 0239 388 0	CONTACT WASHER	A10-10,2X22,25X1,6	15	
26	00 0237 874 0	HEXAGON HEAD BOLT	M10X35	2	
26	00 0236 171 0	HEXAGONAL NUT	M10	2	
26	00 0239 388 0	CONTACT WASHER	A10-10,2X22,25X1,6	2	
27	00 0237 054 0	COUNTERSUNK RIVET	6 X30	2	
27	00 0237 664 0	COUNTERSUNK RIVET	6X20	2	
27	00 0235 464 0	1/2 ROUND RIVET	6 X 28	9	
28	00 0676 249 1	DOUBLE FINGER		4	
28	00 0626 294 0	DOUBLE FINGER		4	5)
29	00 0239 389 0	CONTACT WASHER	A12	2	
30	00 0236 056 0	HEXAGON HEAD BOLT	M12X25	2	

CUTTER BAR 1)

Pos.	Part No.	Description	Dimension	Quantity	Conditions
31	00 0673 752 2	KNIFE CUTTERBAR	50X50X7X4815	1	
32	00 0235 090 0	SPLIT PIN	4 X 28	1	
33	00 0244 455 0	CASTELLATED NUT	M16X1,5	1	
34	00 0645 370 0	RUBBER CAP	D 37	1	
35	00 0100 144 0	BALL JOINT		1	
36	00 0676 231 0	CONNCETION-STEEL		1	
36	00 0626 755 0	CONNCETION-STEEL		1	7)
37	00 0616 286 0	SCRAPER BLADE		1	
38	00 0610 049 0	TENSION SPRING	2 X 16,5X 65	4	
39	00 0770 488 0	SAFETY BAR	2 X 46,5X2100	1	
39	00 0770 489 0	SAFETY BAR	2X46,5X1800	1	
39	00 0770 490 1	SAFETY BAR	2 X 46,5X2400	1	
39	00 0610 059 1	SAFETY BAR	2X46,5X3020	1	
40	00 0176 044 0	CROP LIFTER		1	8)
40	00 0176 078 0	LOCKING CLIP		1	11)
41	00 0176 045 0	CROP LIFTER		1	8)
42	00 0610 294 4	CROP LIFTER		1	8)
43	00 0610 272 3	CROP LIFTER		1	
44	00 0626 407 0	SERRATED BOLT		1	7)
45	00 0626 408 0	LOCK NUT		1	7)
46	00 0626 406 0	SERRATED BOLT		9	7)
47	00 0237 664 0	COUNTERSUNK RIVET	6X20	2	
48	00 0753 917 0	RIVETING TOOL		1	12)
49	00 0233 456 0	HEXAGON HEAD BOLT	M12X30	1	

1)	Remarks	at 4.5 m cutterbar
2)	Remarks	500 long
3)	Remarks	from cutterbar 70200358
4)	Remarks	to cutterbar 70200357
5)	Remarks	reinforced
6)	Remarks	(29)
7)	Remarks	at serrated knife
8)	Remarks	optional
9)	Remarks	from cutterbar 70200031
10)	Remarks	to cutterbar 70200030
11)	Remarks	SONDERWUNSCH
12)	Remarks	with Item 49

CLAAS

5,1m Schneidwerk

7

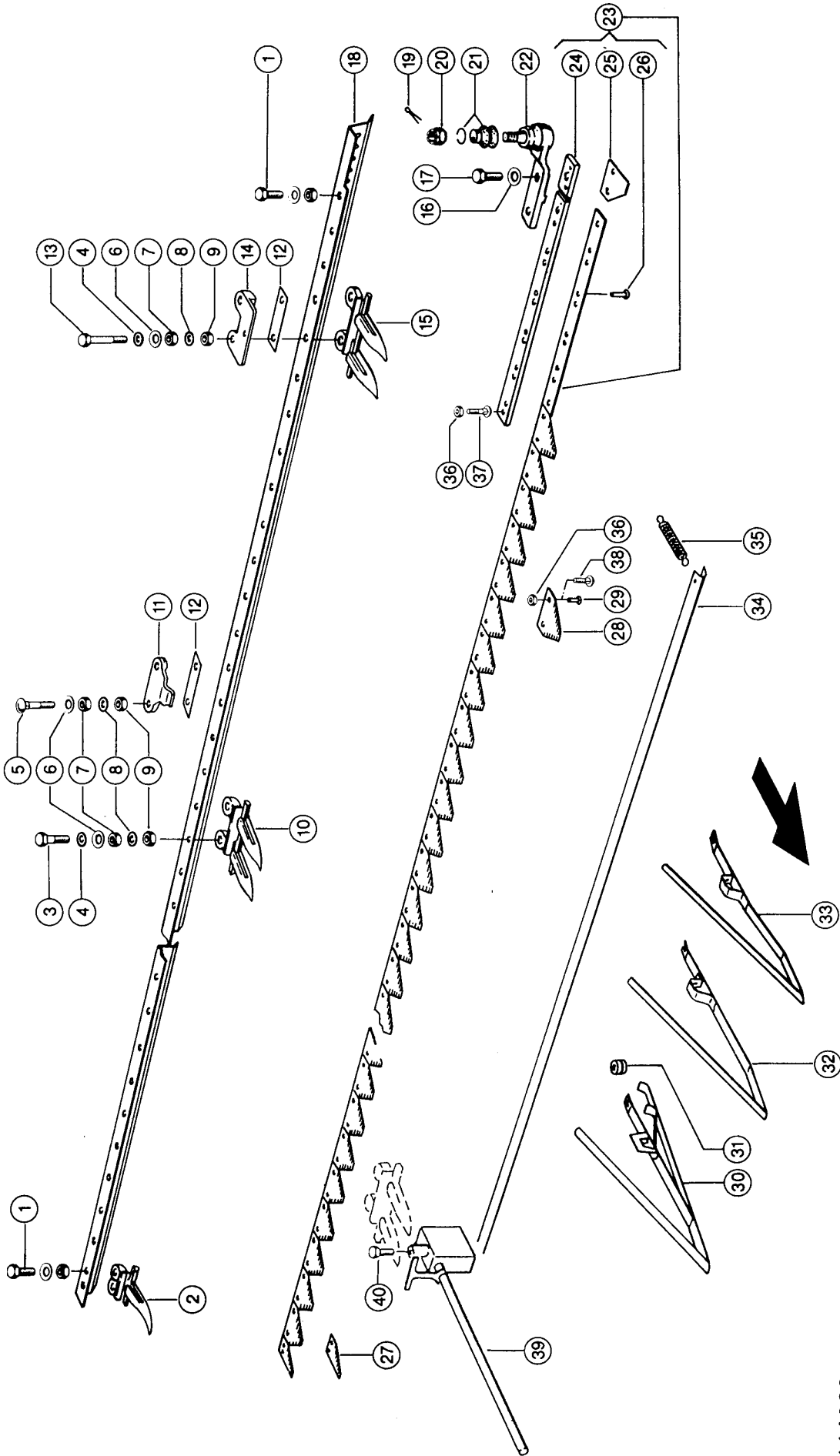

114060

Dominator 218 / 208 MEGA

CUTTER BAR 1)

Pos.	Part No.	Description	Dimension	Quantity	Conditions
1	00 0235 530 0	HEX.HEAD BOLT	M10X30	3	2)
1	00 0237 874 0	HEXAGON HEAD BOLT	M10X35	3	3)
1	00 0236 171 0	HEXAGONAL NUT	M10	3	
1	00 0239 388 0	CONTACT WASHER	A10-10,2X22,25X1,6	3	
2	00 0626 296 3	END FINGER		1	4)
3	00 0235 534 1	HEXAGON HEAD BOLT	M10X50X29	35	5)
4	00 0238 292 0	WASHER	10,5X 22 X1	37	
5	00 0236 462 0	COACH BOLT	M10X60	30	
6	00 0235 133 1	SPRING WASHER	10 -10,2X18,1X1,8	67	
7	00 0236 171 0	HEXAGONAL NUT	M10	67	
8	00 0236 831 0	WASHER	10,5X25X2	67	
9	00 0237 947 0	HEX. NUT WITH CLAMP. PART	M10	67	
10	00 0626 295 1	DOUBLE FINGER		30	4)
11	00 0626 749 1	KNIFE CLIP		15	2)
11	00 0676 236 0	PRESSURE THUMB		15	3)
11	00 0626 749 1	KNIFE CLIP		15	6)
12	00 0688 957 0	SHIM		1	
12	00 0673 753 1	SHIM		1	
13	00 0236 464 0	COACH BOLT	M10X 70	2	7)
13	00 0237 808 0	HEXAGON HEAD BOLT	M10X75	4	8)
14	00 0626 748 1	KNIFE CLIP		1	7)
14	00 0613 017 2	KNIFE CLIP		2	8)
14	00 0626 748 1	KNIFE CLIP		1	6)
15	00 0626 294 0	DOUBLE FINGER		4	4)
16	00 0239 389 0	CONTACT WASHER	A12	2	
17	00 0236 056 0	HEXAGON HEAD BOLT	M12X25	2	
18	00 0638 701 0	KNIFE CUTTERBAR	5425 LG	1	
19	00 0235 090 0	SPLIT PIN	4 X 28	1	
20	00 0244 455 0	CASTELLATED NUT	M16X1,5	1	
21	00 0645 370 0	RUBBER CAP	D 37	1	
22	00 0100 144 0	BALL JOINT		1	
23	00 0611 214 3	MOWER KNIFE		1	
23	00 0626 728 0	MOWER KNIFE		1	6)
23	00 0676 322 1	MOWER KNIFE, PLAIN		1	9)
24	00 0676 231 0	CONNCETION-STEEL		1	
24	00 0626 755 0	CONNCETION-STEEL		1	6)
25	00 0616 286 0	SCRAPER BLADE		1	
26	00 0237 054 0	COUNTERSUNK RIVET	6 X30	14	
26	00 0237 664 0	COUNTERSUNK RIVET	6X20	2	10)
27	00 0611 204 1	KNIFE SECTION		1	
27	00 0611 319 0	KNIFE SECTION PL.		1	
28	00 0611 203 1	KNIFE SECTION		68	
28	00 0611 318 0	KNIFE SECTION PL.		68	
29	00 0237 663 0	COUNTERSUNK RIVET	6X17	1	
30	00 0176 044 0	CROP LIFTER		1	9)
30	00 0176 078 0	LOCKING CLIP		1	11)
31	00 0176 045 0	CROP LIFTER		1	9)
32	00 0610 294 3	CROP LIFTER		1	9)
33	00 0626 299 1	CROP LIFTER		15	
34	00 0610 059 1	SAFETY BAR	2X46,5X3020	1	
34	00 0770 488 0	SAFETY BAR	2 X 46,5X2100	1	
35	00 0610 049 0	TENSION SPRING	2 X 16,5X 65	4	
36	00 0626 408 0	LOCK NUT		1	6)
37	00 0626 406 0	SERRATED BOLT		9	6)

Thank you so much for reading.
Please click the “Buy Now!”
button below to download the
complete manual.



After you pay.

You can download the most
perfect and complete manual in
the world immediately.

Our support email:

ebooklibonline@outlook.com