

201

QUANTUM 5700 P / 4700 P

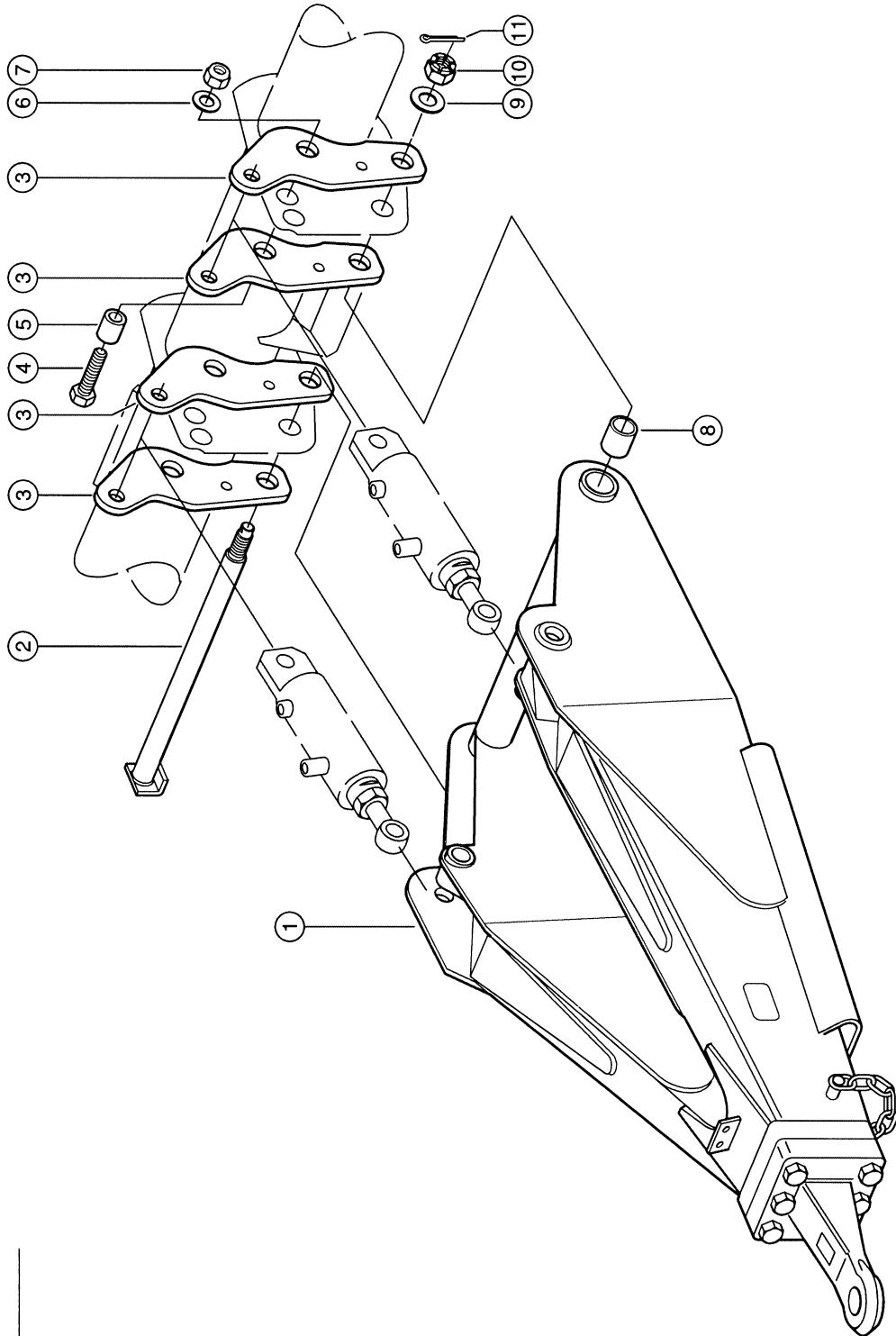

CLAAS



DRAWBAR 1)

Pos.	Part No.	Description	Dimension	Quantity	Conditions
1	00 0970 240 0	DRAWBAR	DRUCKLUFT	1	2)
1	00 0970 239 0	DRAWBAR	HITCH	1	3)
2	00 0963 664 2	SHAFT		1	4)
2	00 0970 309 1	SHAFT		1	5)
3	00 0970 493 1	PLATE	10X 154X 339,6	4	
4	00 0212 608 0	HEXAGON HEAD SCREW	M24X70X38	2	
4	00 0242 422 0	HEXAGON HEAD BOLT	M24X80	2	
5	00 0973 167 0	BUSHING	D33X33,8	2	
5	00 0973 147 0	BUSHING	D33X38,8	2	
6	00 0233 967 0	CONICAL SPRING WASHER	24 -25X56X6	4	
7	00 0238 643 0	HEXAGONAL NUT	M24	2	
8	00 0969 368 0	SYNTHETIC BUSH	34 X 38 X25	4	
9	00 0237 590 2	WASHER	30	2	
10	00 0238 208 0	CASTELLATED NUT	M30X1,5	1	
11	00 0237 883 0	SPLIT PIN	6,3X 50	1	

1) Remarks	Quantum 5700 P / 4700 P Up To Serial No. 615 0 2523
2) Remarks	Component on illustr. 205
3) Remarks	Component on illustr. 204 hitch
4) Remarks	4700 P
5) Remarks	5700 P

202

CLAAS

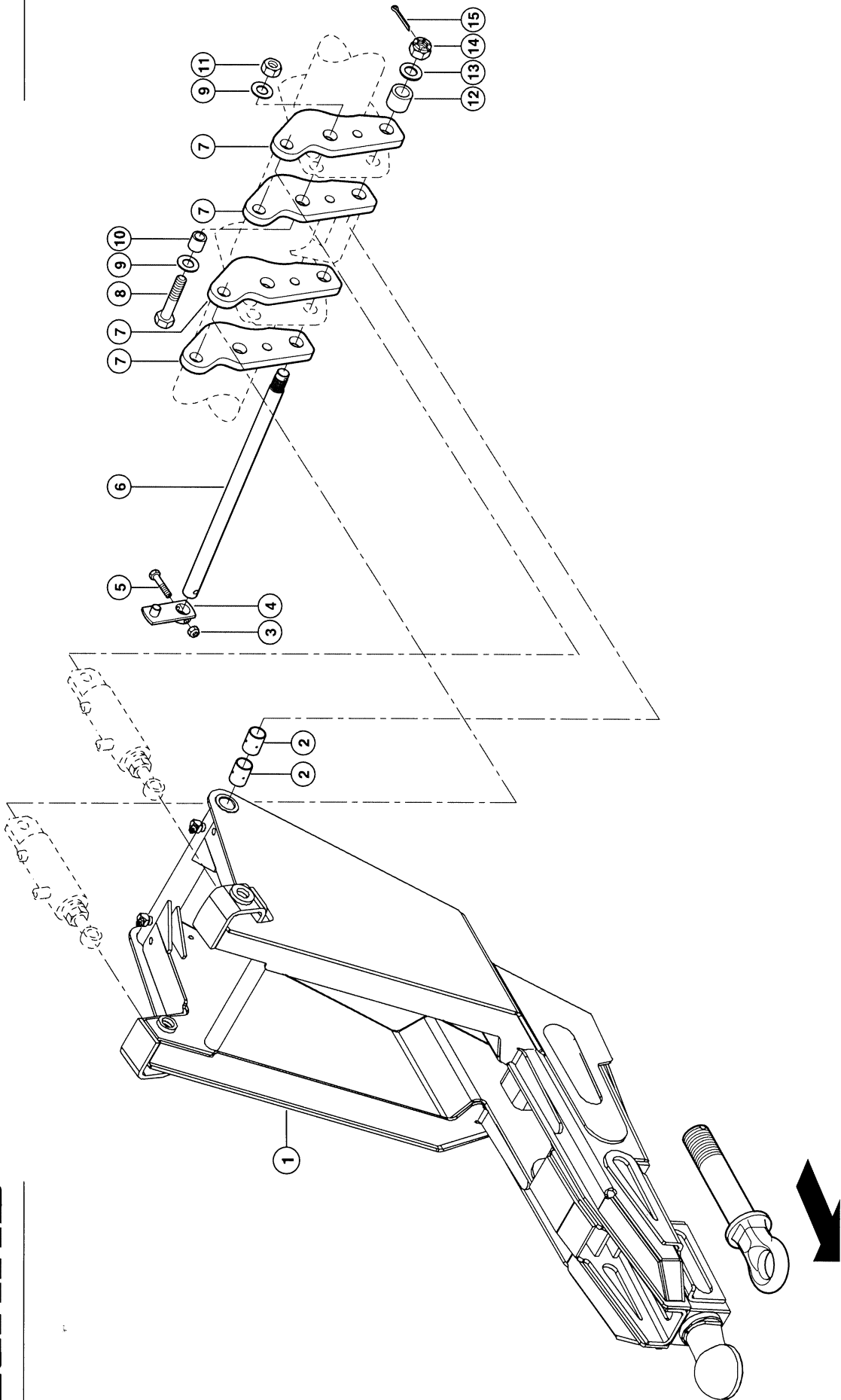

QUANTUM 5700 P / 4700 P

80157Z00

DRAWBAR 1)

Pos.	Part No.	Description	Dimension	Quantity	Conditions
1	00 0493 635 0	DRAWBAR CPL.	HITCH-RINGZUOSEE 16TO	1	2)
1	00 0493 473 0	DRAWBAR CPL.	HITCH-KUGEL-80 16TO	1	3)
2	00 0493 082 1	BUSHING	33X 38X 50	4	
3	00 0238 006 0	LOCK NUT	M10	1	
4	00 0493 072 1	STRAP		1	
5	00 0233 445 0	HEXAGON HEAD BOLT	M10X65	1	
6	00 0493 543 0	SHAFT	RD33X 640	1	
7	00 0970 493 1	PLATE	10X 154X 339,6	4	
8	00 0242 422 0	HEXAGON HEAD BOLT	M24X80	2	
9	00 0233 967 0	CONICAL SPRING WASHER	24 -25X56X6	4	
10	00 0973 167 0	BUSHING	D33X33,8	2	
11	00 0238 643 0	HEXAGONAL NUT	M24	2	
12	00 0973 204 0	ROLLER	D 50H9X 40	1	
13	00 0237 590 2	WASHER	30	2	
14	00 0238 208 0	CASTELLATED NUT	M30X1,5	1	
15	00 0237 883 0	SPLIT PIN	6,3X 50	1	

1) Remarks Quantum 5700 P / 4700 P
Up To Serial No. 615 0 2523

2) Remarks Component on illustr. 207
Hitch towing eye

3) Remarks Component on illustr. 207
hitch - ball 80

203

QUANTUM 5800 P

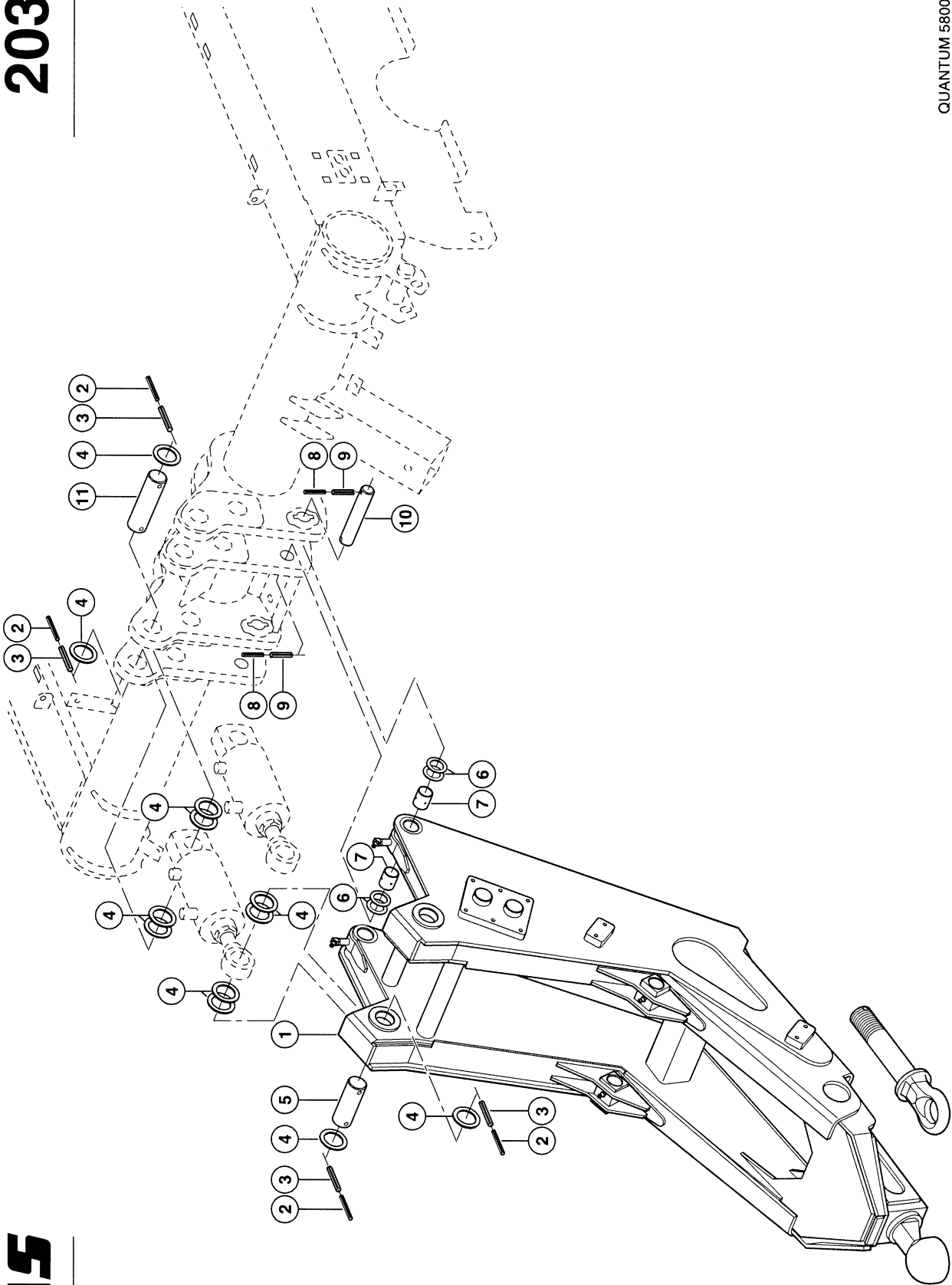

CLAAS



80159700

DRAWBAR 1)

Pos.	Part No.	Description	Dimension	Quantity	Conditions
1	00 0493 699 0	DRAWBAR CPL.	HITCH-KUGEL-80	1	2)
1	00 0493 698 0	DRAWBAR CPL.	HITCH-RINGZUGOESE 22,5"/	1	3)
2	00 0237 608 2	SPRING PIN	6 X 70	8	
3	00 0237 614 2	SPRING PIN	10X 70 -ST	8	
4	00 0233 588 0	WASHER	50X70X3	1	
5	00 0493 722 0	PIN	D35X	2	
6	00 0236 858 0	WASHER	36X52X1	8	
7	00 0493 704 0	BUSHING	35X 40X 45	4	
8	00 0212 508 1	SPRING PIN	6 X 50	4	
9	00 0237 612 2	SPRING PIN	10X 50	4	
10	00 0493 711 0	PIN	D35X 187	2	
11	00 0493 710 0	PIN	D50X 180	2	
1)	Remarks	Quantum 5800 P Up To Serial No. 615 0 2523			
2)	Remarks	Component on illustr. 206 hitch - ball 80			
3)	Remarks	Component on illustr. 206 Hitch towing eye			

204

QUANTUM 4700 F

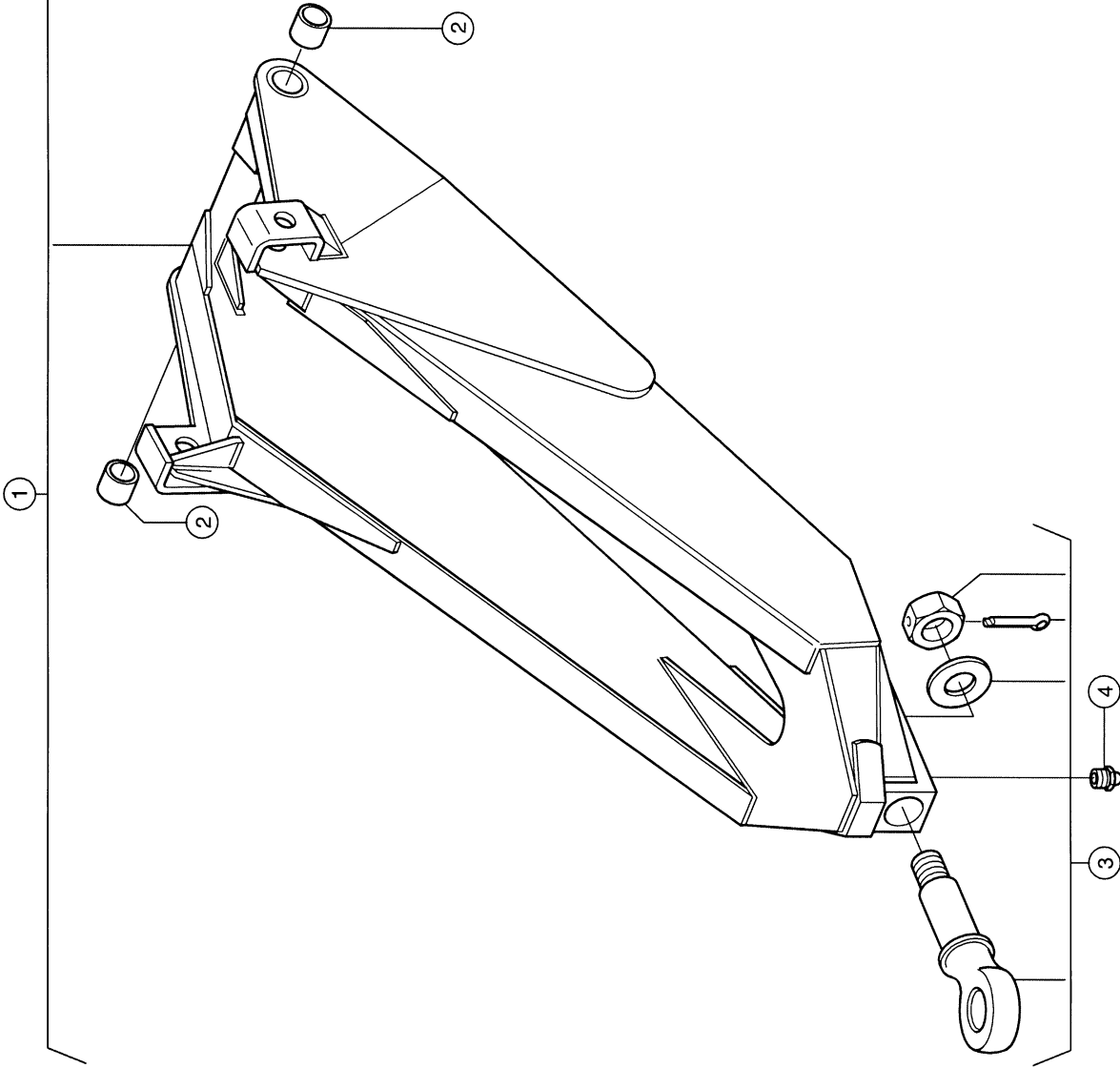

CLAAS



93737C

HYDRAULIC ARTICULATED DRAWBAR - HITCH 1)

Pos.	Part No.	Description	Dimension	Quantity	Conditions
1	00 0970 239 0	DRAWBAR	HITCH	1	2)
2	00 0969 368 0	SYNTHETIC BUSH	34 X 38 X25	2	
3	00 0939 910 0	HITCH EYE	OT 050	1	
4	00 0244 949 0	GREASE NIPPLE	A M10X1	1	
1)	Remarks	Quantum 4700 P Up To Serial No. 615 0 2523			
2)	Remarks	M02 0050			

CLAAS

205

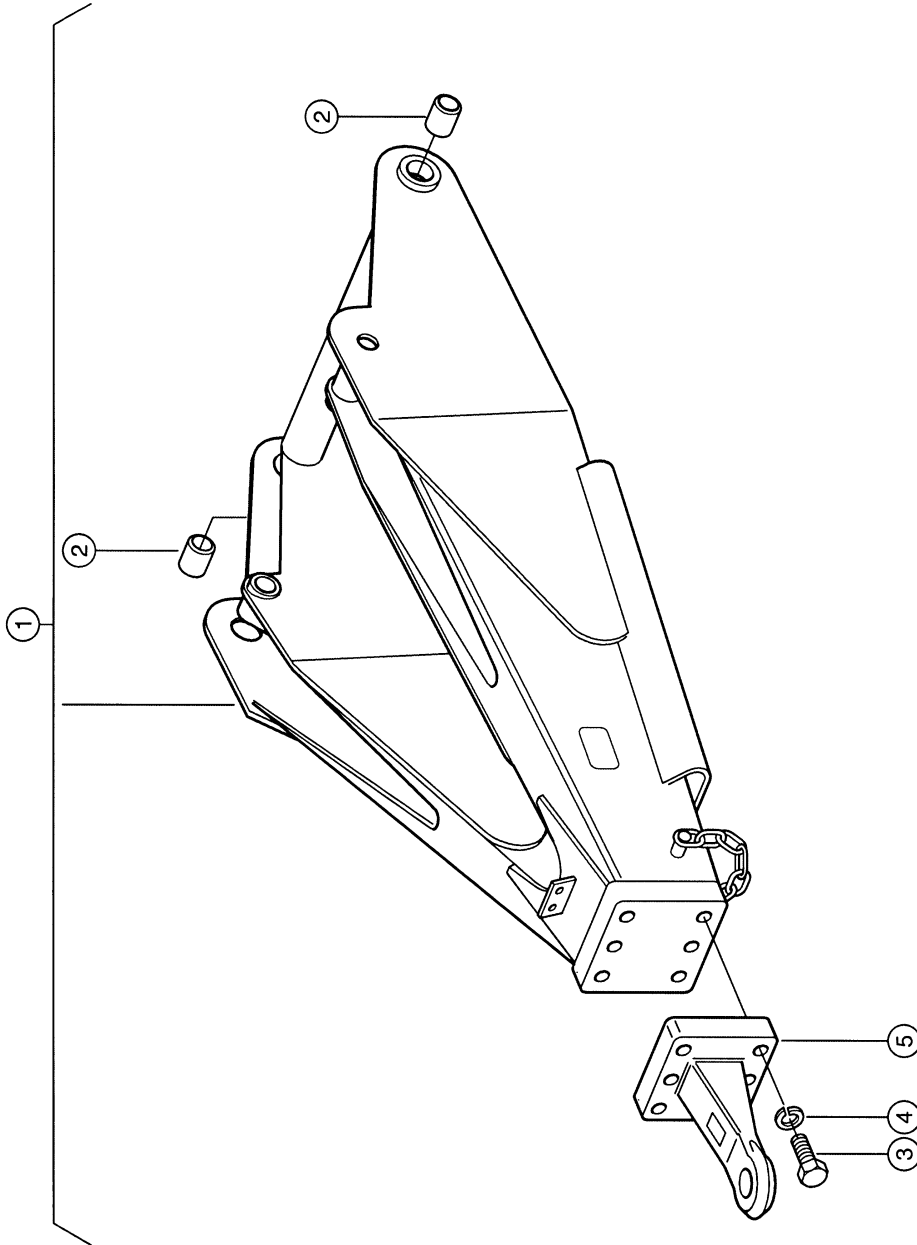

QUANTUM 5700 P / 4700 P



93738C

HYDRAULIC ARTICUL. DRAWBAR 1)

Pos.	Part No.	Description	Dimension	Quantity	Conditions
1	00 0970 240 0	DRAWBAR	DRUCKLUFT	1	2)
2	00 0969 368 0	SYNTHETIC BUSH	34 X 38 X25	2	
3	00 0235 587 0	HEXAGON HEAD BOLT	M16-55	6	
4	00 0235 135 1	SPRING WASHER	16- 16,2X27,4X2,8	6	
5	00 0939 617 0	DRAW BAR EYE	40-B	1	
1)	Remarks	Quantum 5700 P / 4700 P Up To Serial No. 615 0 2523			
2)	Remarks	m02 0070			

206

CLAAS

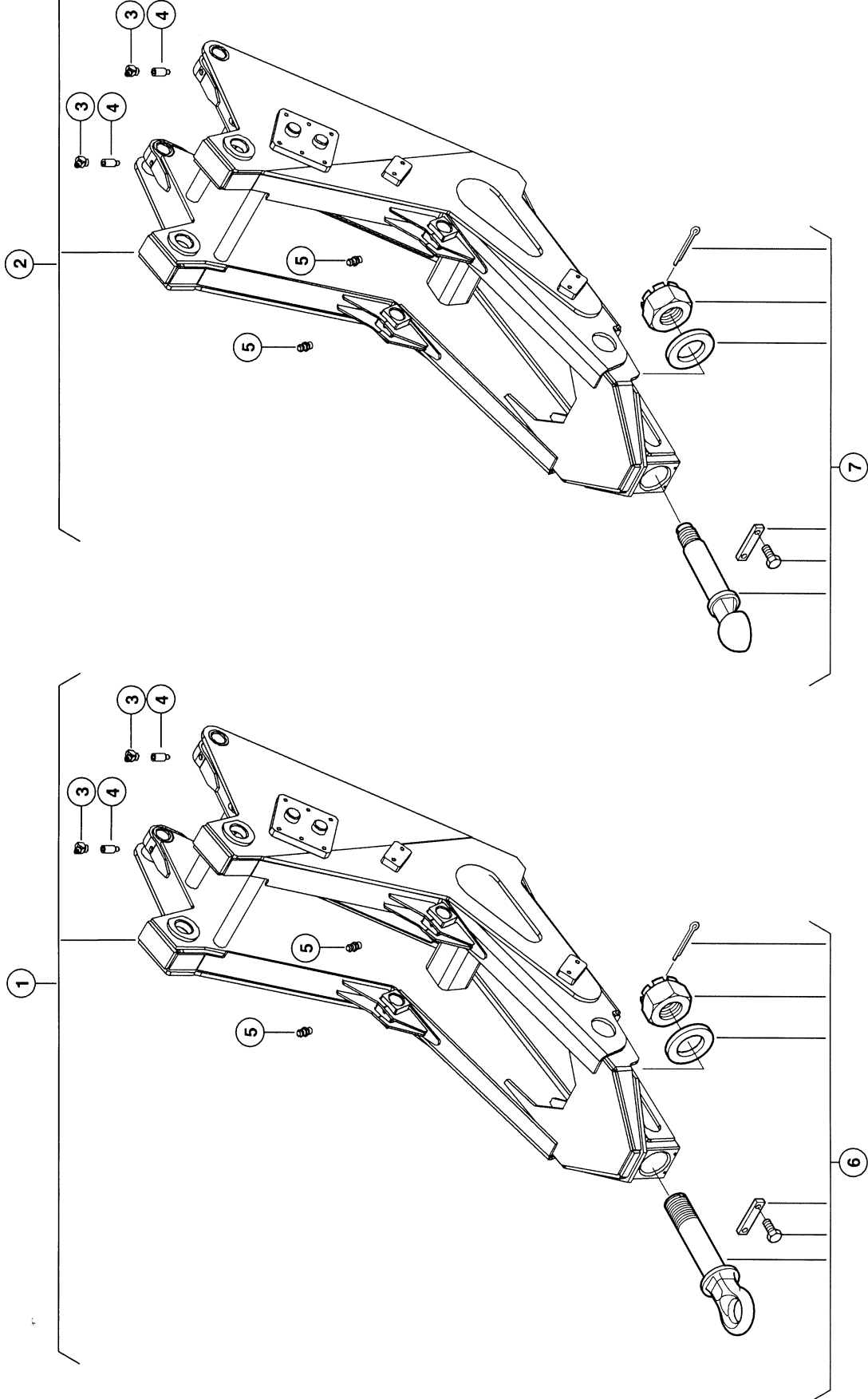

QUANTUM 5800 P

80158Z00

HYDRAULIC ARTICUL. DRAWBAR 1)

Pos.	Part No.	Description	Dimension	Quantity	Conditions
1	00 0493 698 0	DRAWBAR CPL.	HITCH-RINGZUGOESE 22,5"/	1	2)
2	00 0493 699 0	DRAWBAR CPL.	HITCH-KUGEL-80	1	3)
3	00 0244 947 0	GREASE NIPPLE	C M6	2	
4	00 0138 269 0	TRUNNION		2	
5	00 0244 949 0	GREASE NIPPLE	A M10X1	2	
6	00 0920 271 0	DRAW BAR EYE	19,0 DL	1	2)
7	00 0920 272 0	DRAW BAR EYE	D=80	1	3)
1)	Remarks	Quantum 5800 P Up To Serial No. 615 0 2523			
2)	Remarks	Hitch eye			
3)	Remarks	Hitch ball 80			

207

CLAAS

QUANTUM 5700 P / 4700 P

80160z00

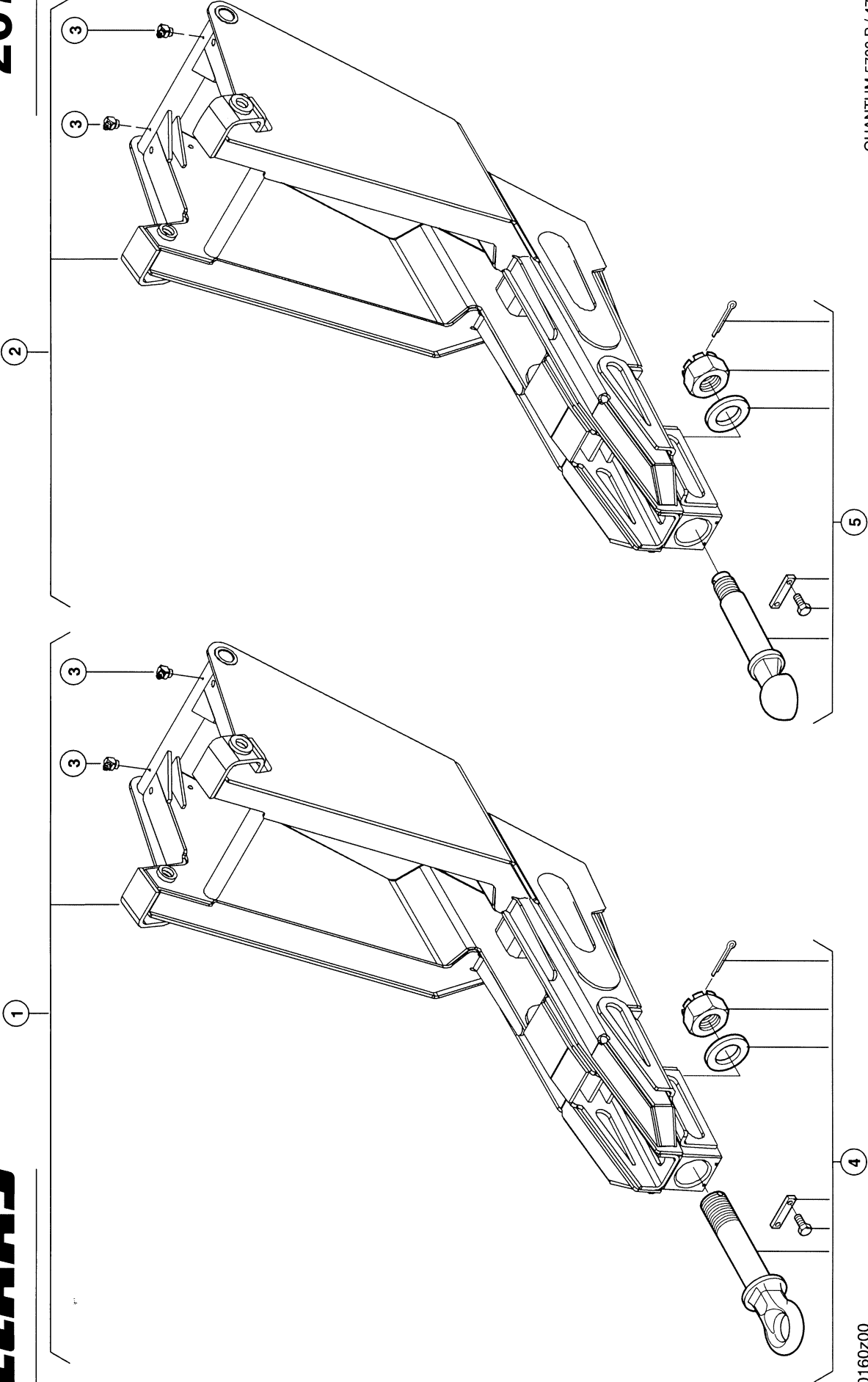

HYDRAULIC ARTICUL. DRAWBAR 1)

Pos.	Part No.	Description	Dimension	Quantity	Conditions
1	00 0493 635 0	DRAWBAR CPL.	HITCH-RINGZUOSE 16TO	1	2)
2	00 0493 473 0	DRAWBAR CPL.	HITCH-KUGEL-80 16TO	1	3)
3	00 0244 947 0	GREASE NIPPLE	C M6	2	
4	00 0920 271 0	DRAW BAR EYE	19,0 DL	1	2)
5	00 0920 272 0	DRAW BAR EYE	D=80	1	3)
1)	Remarks	Quantum 5700 P / 4700 P Up To Serial No. 615 0 2523			
2)	Remarks	Hitch eye			
3)	Remarks	Hitch ball 80			

208

CLAAS

QUANTUM 6800 P / 5800 P / 5700 P / 4700 P

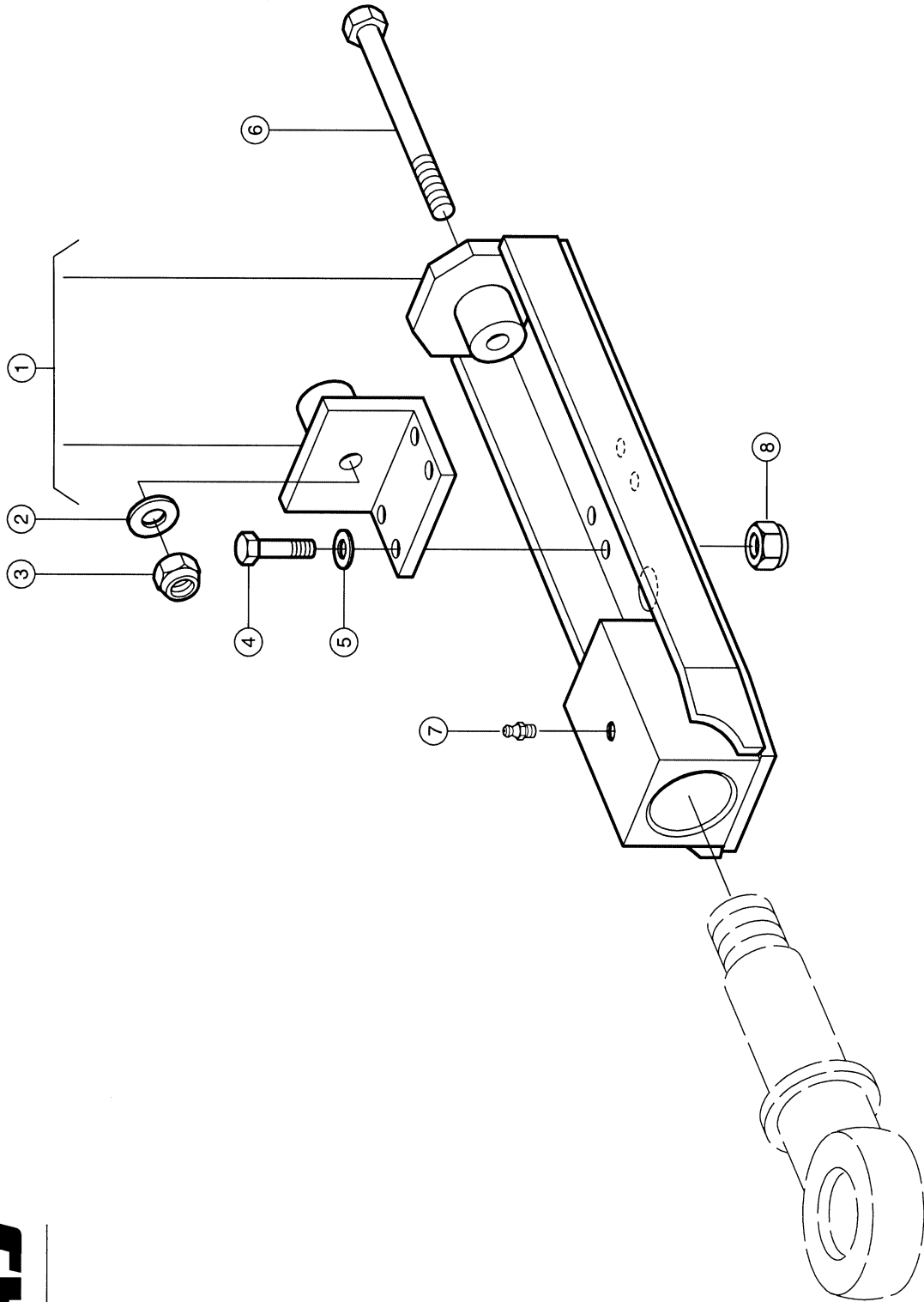

92726C/01

Thank you so much for reading.
Please click the “Buy Now!”
button below to download the
complete manual.



After you pay.

You can download the most
perfect and complete manual in
the world immediately.

Our support email:

ebooklibonline@outlook.com