

Product: EXCAVATOR

Model: 319D EXCAVATOR BZH

Configuration: 319D Excavators BZH00001-UP (MACHINE) POWERED BY C4.2 Engine

Disassembly and Assembly 315D, 318D and 319D Excavators Machine Systems

Media Number -KENR5272-13

Publication Date -01/09/2017

Date Updated -06/09/2017

i05453130

Final Drive - Disassemble

SMCS - 4050-015

Disassembly Procedure

Table 1

Required Tools			
Tool	Part Number	Part Description	Qty
A	1P-2420	Transmission Repair Stand	1
B	439-3938	Link Bracket	2
C	154-6181	Forcing Bolt	1
D	439-3940	Link Bracket	2
E	5F-7366	Forcing Bolt	1
	1P-5546	Crossblock	1
	1U-9889	Crossblock	1
	1P-0520	Driver Group	1
	6V-7888	Puller Leg	2
	1H-3112	Puller Assembly	1
	1P-5551	Adjustable Screw Assembly	1
F	-	Loctite 5127	1

Start By:

- a. Remove the final drive.

Note: Cleanliness is an important factor. Before the disassembly procedure, thoroughly clean the exterior of the component. This action will prevent dirt from entering the internal mechanism.

1. Put an alignment mark across the sections of the final drive for assembly purposes. The parts must be reinstalled in the original locations.



Illustration 1

g00708089

2. Fasten the final drive to Tooling (A), as shown. The combined weight of the final drive and final drive sprocket is approximately 312 kg (688 lb).
3. Remove bolts (1) and the washers that hold the cover in position.

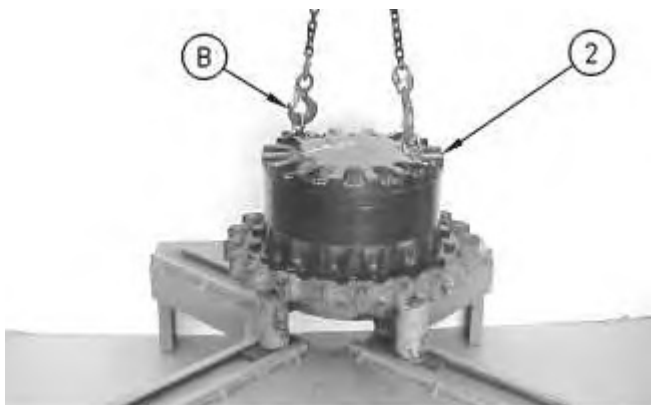

Illustration 2

g00708090

4. Remove the setscrews from cover (2), and fasten Tooling (B) and a suitable lifting device to cover (2), as shown. The weight of cover (2) is approximately 32 kg (70 lb). Remove cover (2).
-

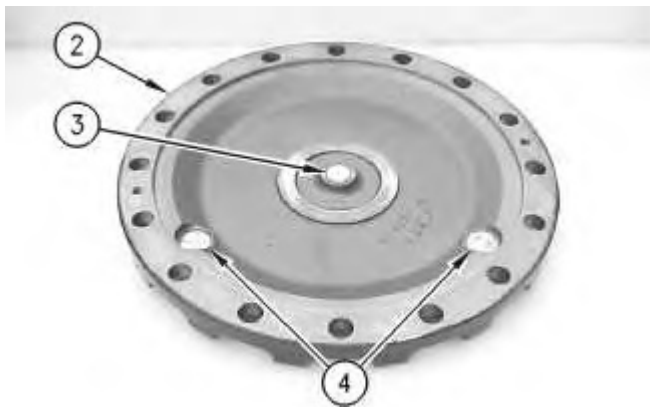

Illustration 3

g00708091

5. Remove thrust plate (3) from cover (2).
6. Remove plugs (4) from cover (2).

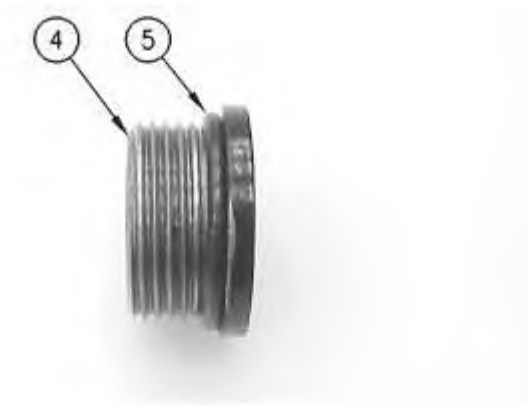

Illustration 4

g00708235

7. Remove O-ring seals (5) from both plugs (4) that were in the cover.

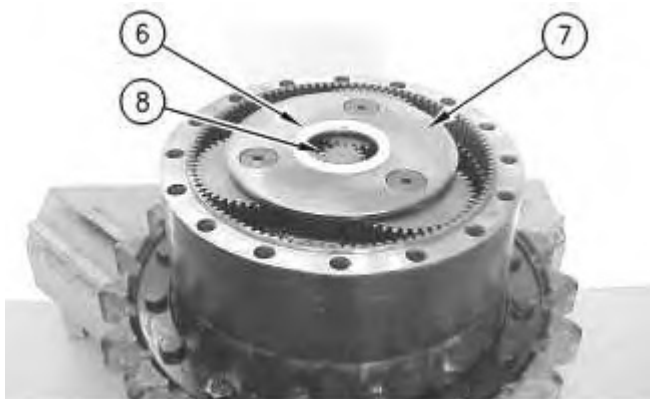

Illustration 5

g00708092

8. Remove spacer (6) from carrier assembly (7).
9. Remove sun gear (8) from carrier assembly (7).

10. Remove carrier assembly (7) by lifting the carrier assembly straight up. The weight of carrier assembly (7) is approximately 14 kg (30 lb).



Illustration 6

g01304883

11. Disassemble carrier assembly (7), as follows.

- a. Drive spring pin (10) into planetary shaft (9) with a hammer and a punch.



Illustration 7

g00708144

- b. Remove planetary shaft (9) with spring pin (10) from the carrier assembly.
- c. Remove spring pin (10) from planetary shaft (9) with a hammer and a punch.

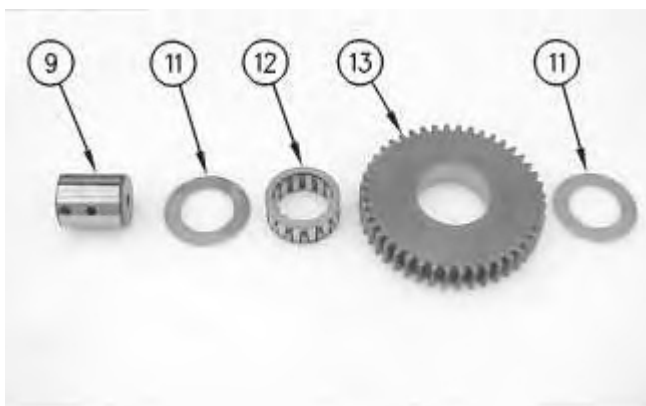

- d. Remove thrust washers (11) and planetary gear (13) from the carrier assembly.
 - e. Remove bearing (12) from planetary gear (13).
12. Repeat Steps 11.a through 11.e in order to remove the remaining planetary gears from the carrier assembly.

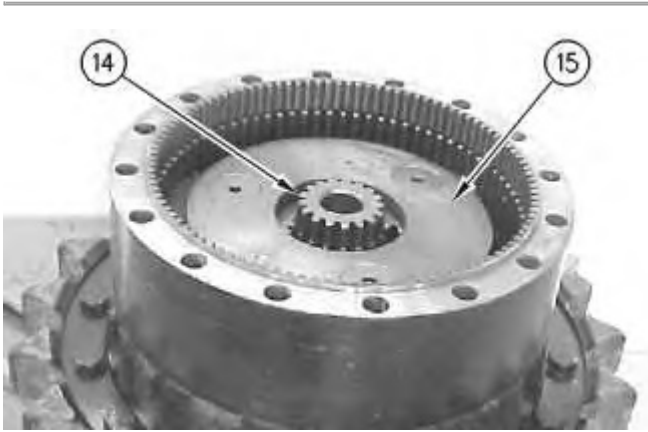

Illustration 9

g00708162

13. Remove sun gear (14) from carrier assembly (15).

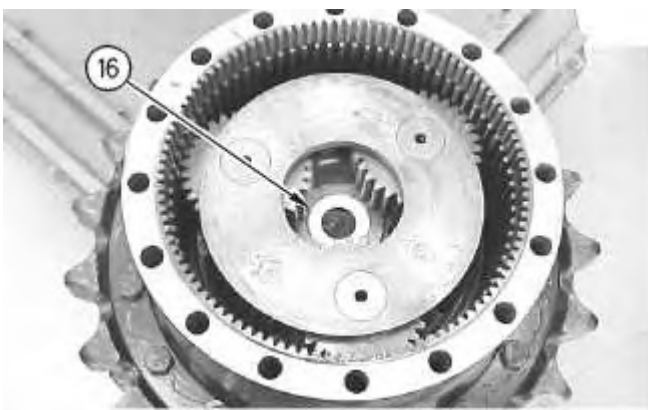

Illustration 10

g00708325

14. Remove spacer (16).
-

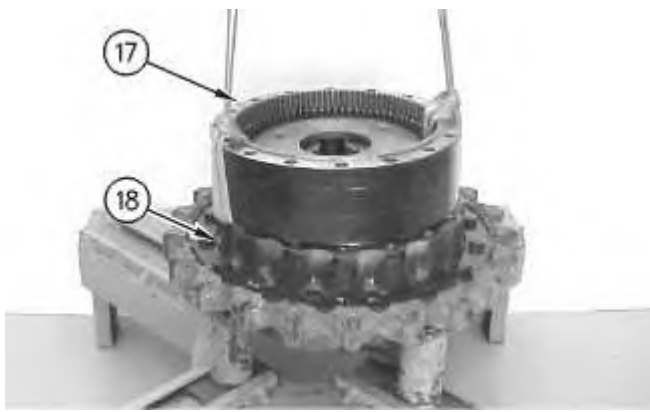

Illustration 11

g00708184

Note: It will be necessary to pry ring gears (17) away from main housing (18) in order to install the lifting slings.

15. Fasten a suitable lifting device to ring gears (17), as shown. Remove the ring gears from main housing (18). The weight of ring gears (17) is approximately 45 kg (100 lb).



Illustration 12

g00708360

16. Use a screwdriver or a chisel in order to separate two ring gears (17).

Note: Two ring gears (17) are held together with Tooling (F). It may be necessary to heat ring gears (17) in order to soften the sealant. Do not heat over 135 °C (275 °F) for more than thirty minutes.

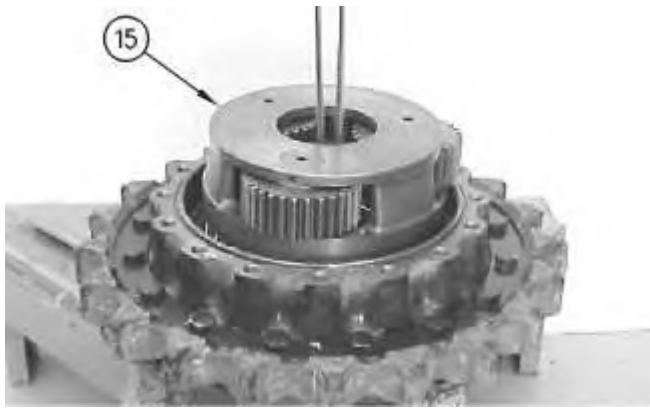

Illustration 13

g00708172

17. Position a 12.7 mm (0.50 inch) shackle under carrier assembly (15).
18. Fasten a suitable lifting device to the shackle.
19. Slowly lift carrier assembly (15) from the final drive. The weight of carrier assembly (15) is approximately 39 kg (85 lb).
20. Disassemble carrier assembly (15), as follows.



Illustration 14

g00708175

- a. Drive spring pin (20) into planetary shaft (19) with a hammer and a punch.



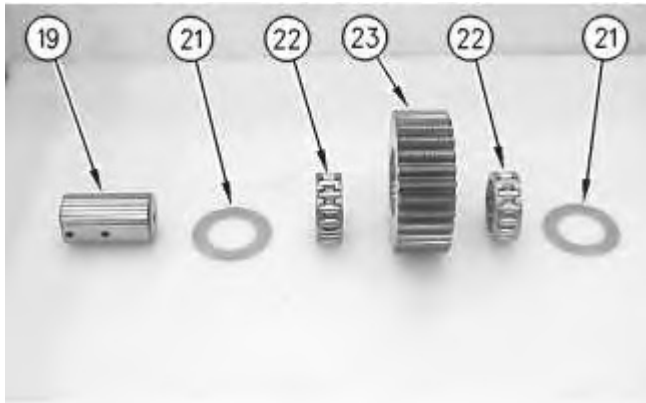

Illustration 16

- b. Remove planetary shaft (19) with spring pin (20) from the carrier assembly.
 - c. Remove spring pin (20) from planetary shaft (19) with a hammer and a punch.
 - d. Remove thrust washers (21) and planetary gear (23) from the carrier assembly.
 - e. Remove bearings (22) from planetary gear (23).
21. Repeat Steps 20.a through 20.e in order to remove the remaining planetary gears from the carrier.

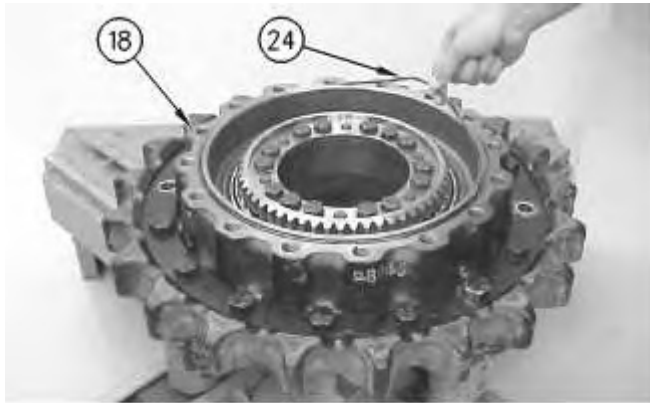

Illustration 17

22. Remove O-ring seal (24) from main housing (18).
-

Thank you so much for reading.
Please click the “Buy Now!”
button below to download the
complete manual.



After you pay.

You can download the most
perfect and complete manual in
the world immediately.

Our support email:

ebooklibonline@outlook.com