



# Service Repair Manual

## **Models**

# 345B EXCAVATOR

---

Product: EXCAVATOR  
Model: 345B EXCAVATOR AMD  
Configuration: ISJ HEX COMMONALITY CHART AMD00001-UP (MACHINE)

## **Disassembly and Assembly 345B, 345B Series II and W345B Series II Excavators Machine Systems**

Media Number -SEN1934-11

Publication Date -01/01/2012

Date Updated -12/01/2012

i01324820

### **Travel Motor - Assemble - Series II**

SMCS - 4351-016

S/N - AGS1-UP

S/N - AKJ1-UP

S/N - AKX1-UP

S/N - ALB1-UP

S/N - ALD1-UP

S/N - AMD1-UP

S/N - AMJ1-UP

S/N - AMN1-UP

S/N - APB1-UP

S/N - AYR1-UP

S/N - CCC1-UP

S/N - DCW1-UP

S/N - DET1-UP

S/N - FEE1-UP

### **Assembly Procedure**

Table 1

--

<b>Required Tools</b>			
<b>Tool</b>	<b>Part Number</b>	<b>Part Description</b>	<b>Qty</b>
(A)	180-6533	Seal Driver	1
(B)	6V-7030	Micrometer Depth Gauge	1
(C)	8T-0447	Calipers	1
(D)	4C-8359	Eyebolt	1
(E)	1P-0510	Driver Group	1
(F)	3E-3879	Eyebolt	1
(G)	1P-1862	Pliers	1

---

### **NOTICE**

**Keep all parts clean from contaminants.**

**Contamination of the hydraulic system with foreign material will reduce the service life of the hydraulic system components.**

**To prevent contaminants from entering the hydraulic system, always plug or cap the lines, fittings, or hoses as they are disconnected. Cover any disassembled components and clean them properly before assembly.**

**Clean the hydraulic system properly after any major component exchange or especially after a component failure, to remove any contamination.**

---

**Note:** If a failure occurs, an accurate diagnosis of the cause can prevent a recurrence. Information is available to analyze failures for piston pumps and motors. Refer to Special Publication, SEBD0641, "Analyzing Axial Piston Pump and Motor Failures".

**Note:** Inspect all parts. If any parts are worn or damaged use new parts for replacement. The installation of used parts during reconditioning is acceptable. Reuse and salvage information is available on piston pumps. Refer to Guideline For Reusable Parts and Salvage Operations, SEBF8032, "Piston Pumps and Motors". During reconditioning, correct any conditions that might have caused the original failure.

**Note:** O-rings, gaskets, and seals should always be replaced. A used O-ring may not have the same sealing properties as a new O-ring. Use **1U-6396** O-Ring Assembly Compound during the assembly procedure.

**Note:** Apply a light film of "10W" oil to all components before assembly.

---

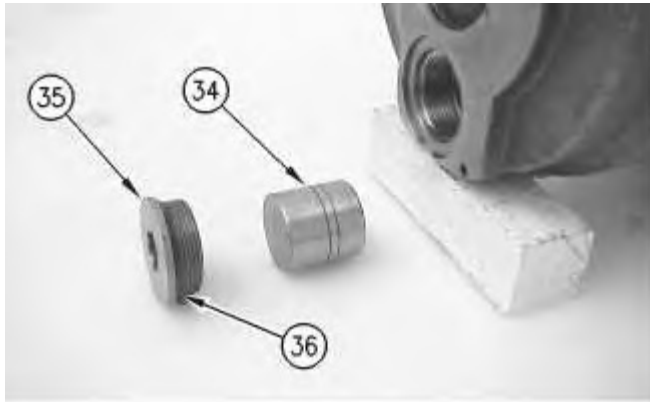

Illustration 1

g00631019

1. Install O-ring seal (36) on plug (35) .
2. Install piston (34) and the plug in the travel motor body. Tighten the plug to a torque of  $430 \pm 40 \text{ N}\cdot\text{m}$  ( $317 \pm 30 \text{ lb ft}$ ).

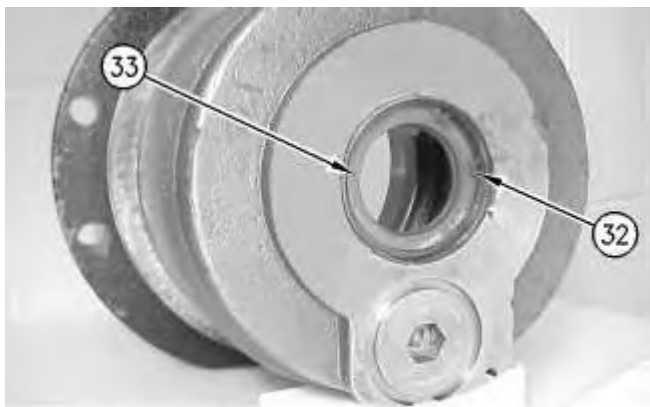

Illustration 2

g00630992



Illustration 3

g00636553

3. Apply a thin coat of **4C-4030** Thread Lock Compound on the outer surfaces of lip type seal (33) .
4. Use Tooling (A) and a suitable hammer to drive the lip type seal into the travel motor body. Drive the seal downward until Tooling (A) makes contact with the travel motor housing.
5. Use Tooling (G) to install retaining ring (32) to the shaft end of the travel motor body.

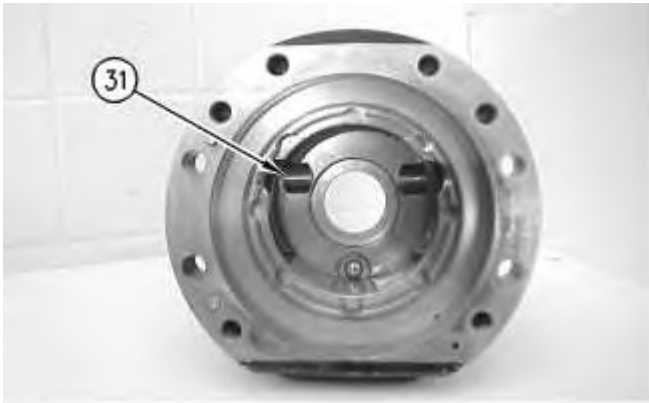

Illustration 4

g00630986

6. Install two keys (31) inside the travel motor body.

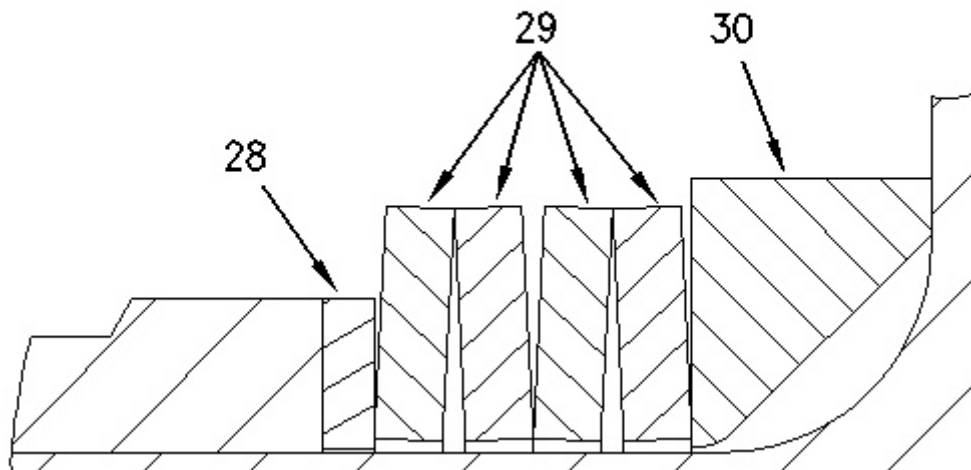

Illustration 5

g00629434

7. Assemble washers (29), inner spacer (30) and outer spacer (28) in the proper orientation, as shown.

Thank you so much for reading.  
Please click the “Buy Now!”  
button below to download the  
complete manual.



After you pay.

You can download the most  
perfect and complete manual in  
the world immediately.

Our support email:

[ebooklibonline@outlook.com](mailto:ebooklibonline@outlook.com)