



Service Repair Manual

Models

637G Wheel Tractor

Product: WHEEL SCRAPER

Model: 637G WHEEL SCRAPER CEM

Configuration: 637G Wheel Scraper Coal Bowl CEM00001-UP (MACHINE) POWERED BY C-9 Engine

Disassembly and Assembly

637G Wheel Tractor-Scraper Wheel Tractor Power Train

Media Number -REN5733-00

Publication Date -01/09/2004

Date Updated -30/09/2004

i02156910

Torque Converter - Assemble

SMCS - 3101-016

Assembly Procedure

Table 1

Required Tools			
Tool	Part Number	Part Description	Qty
A	138-7574	Link Bracket	3
B	1P-1861	Retaining Ring Pliers	1
C	1P-0510	Driver Gp	1
D	7X-0290	Bolt	2

NOTICE

Keep all parts clean from contaminants.

Contamination of the hydraulic system with foreign material will reduce the service life of the hydraulic system components.

To prevent contaminants from entering the hydraulic system, always plug or cap the lines, fittings, or hoses as they are disconnected. Cover any disassembled components and clean them properly before assembly.

Clean the hydraulic system properly after any major component exchange or especially after a component failure, to remove any contamination.

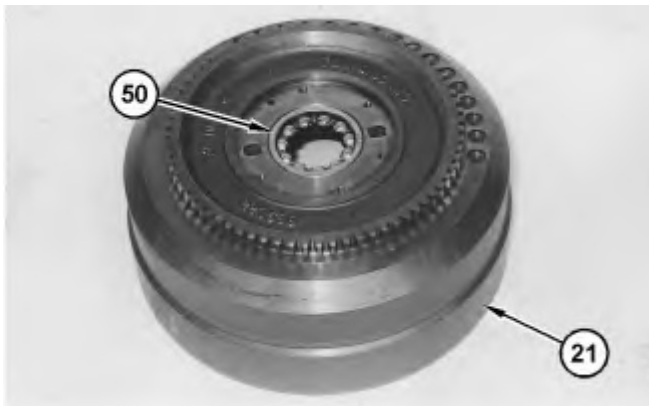

Illustration 1

g01094391

1. Lower the temperature of bearing (50). Install bearing (49) into housing (21) .

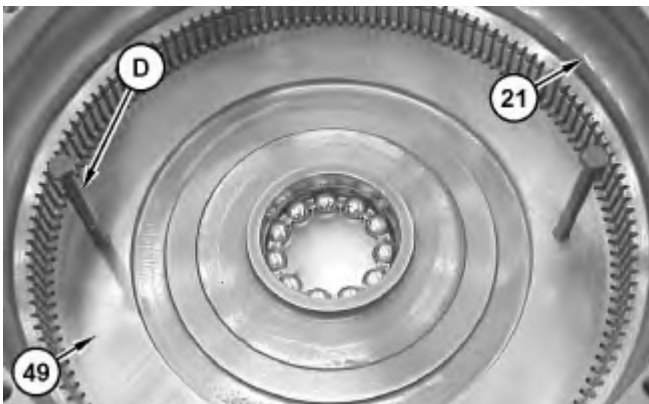
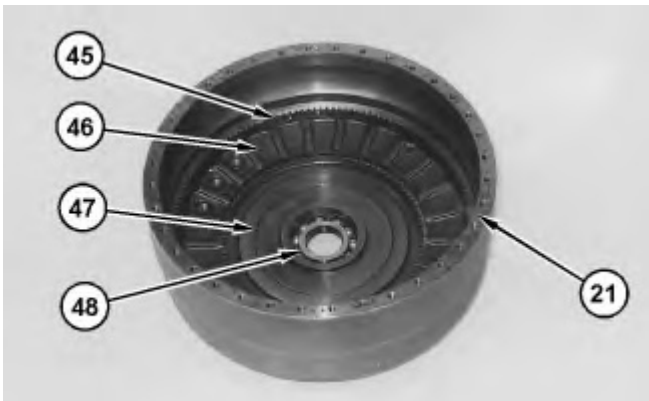

Illustration 2

g01094044

2. Install the seals onto piston (49) and housing (21). Use Tooling (D) in order to install piston (49) into housing (21) .



3. Position housing (21), as shown. Install inner bearing race (48) .
4. Install disc assembly (47) .
5. Install plate (46). Install ring (45) .

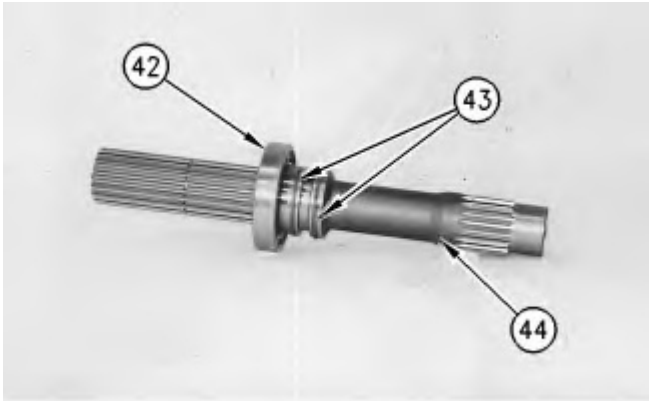

Illustration 4

6. Install rings (43) onto shaft (44) .
7. Lower the temperature of bearing (42). Install bearing (42) onto shaft (44) .

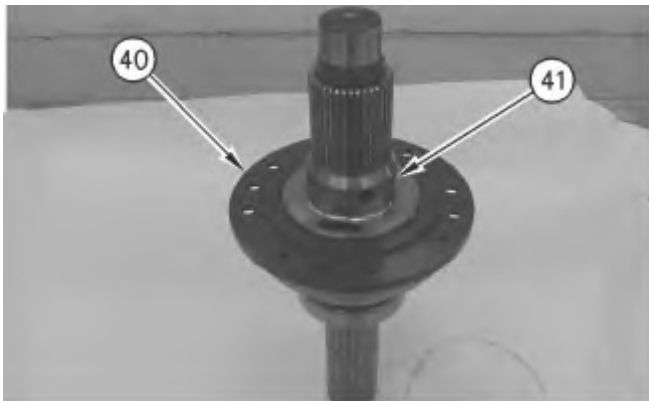

Illustration 5

8. Install carrier (41). Install gear assembly (40) .
-

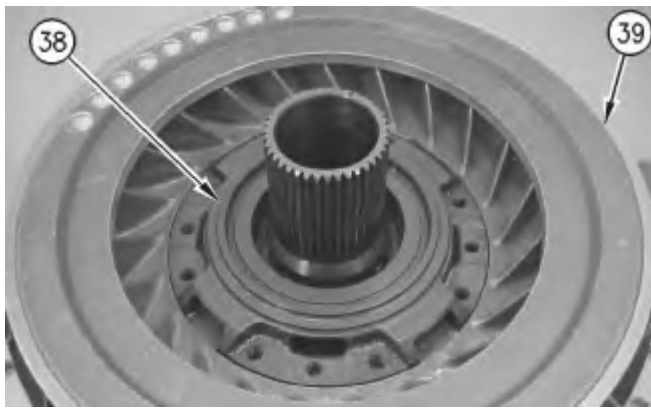

Illustration 6

g00833858

9. Install impeller (39). Install carrier (38) .

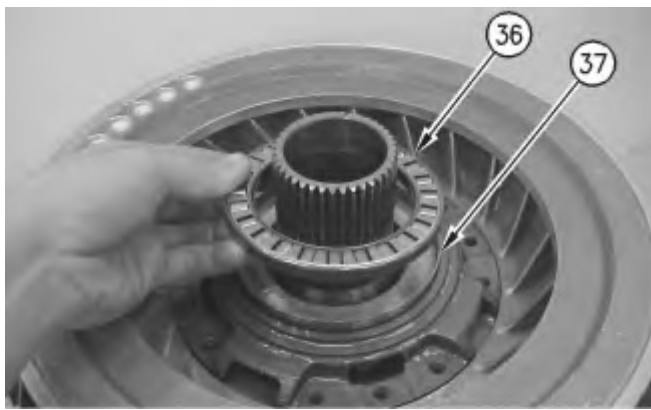

Illustration 7

g00833848

10. Install race (37). Install bearing (36) .

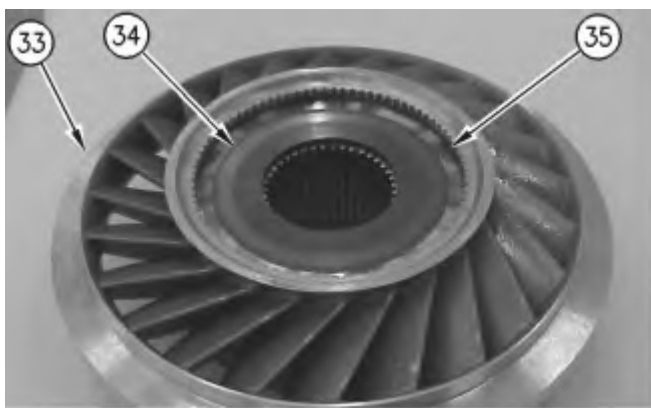

Illustration 8

g00833847

11. Position stator (33), as shown. Install race (35). Install ring (34) .

Thank you so much for reading.
Please click the “Buy Now!”
button below to download the
complete manual.



After you pay.

You can download the most
perfect and complete manual in
the world immediately.

Our support email:

ebooklibonline@outlook.com