

Product: TRACK LOADER

Model: 953 TRACK LOADER 44Z

Configuration: 953 TRACK TYPE LOADER 44Z00001-UP (MACHINE) POWERED BY 3204 ENGINE

## Disassembly and Assembly

### 3204 VEHICULAR ENGINE FOR 943 & 953 TRACK-TYPE LOADERS

Media Number -SEN4214-00

Publication Date -01/04/1985

Date Updated -11/10/2001

## Governor (New Scroll Fuel System Effective In Production With 10X5411-Up, 45V36536-Up)

SMCS - 1264-015; 1264-016

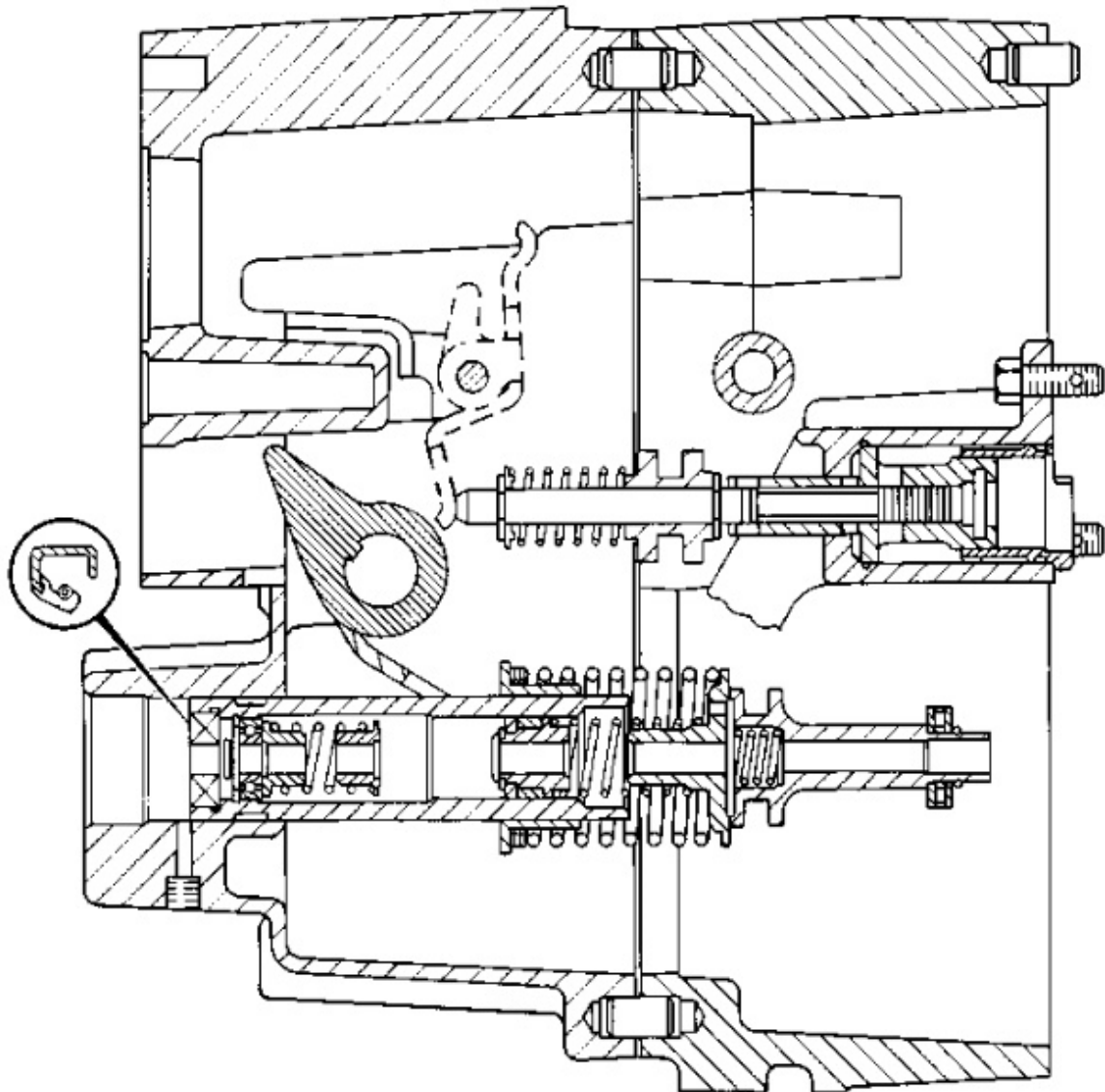

B40324X1

# Disassemble Governor (New Scroll Fuel System Effective In Production With 10X5411-Up, 45V36536-Up)

Tools Needed		A	B	C
1P510	Driver Group	1		
1P1855	Retaining Ring Pliers		1	
6V2163	Compressor Clamp*			1

\*Part of 6V4095 Pump And Governor Reconditioning Tool Group.

START BY:

a. remove fuel injection pump housing and governor (new scroll fuel system effective in production with 10X5411-UP, 45V36536-UP)

b. remove fuel transfer pump (new scroll fuel system effective in production with 10X5411-UP, 45V36536-UP)

**NOTE:** If it is desired to remove only the governor so the fuel injection pump housing can be disassembled, do only Steps 1, 2, 15, 21, 25, 26, 27, 28, 31, 33, 34 and 37.

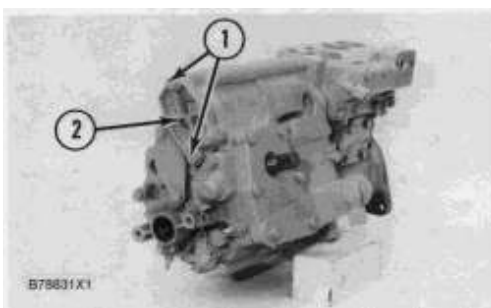
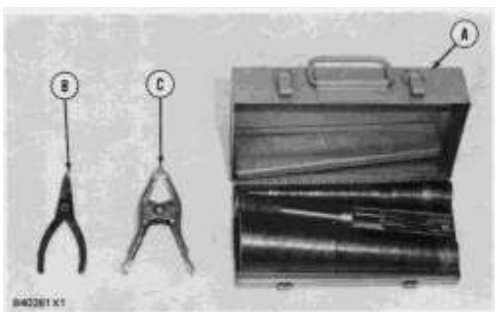

1. Remove bolts (1) and cover (2).

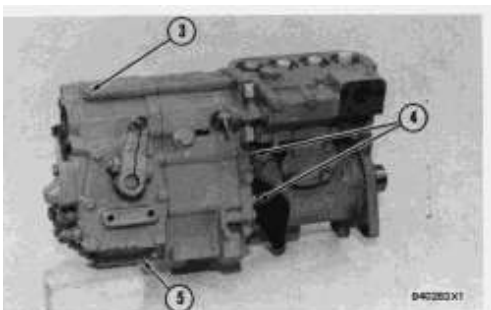

2. Remove six bolts (3), two top bolts (4), housing (5) and the gasket.

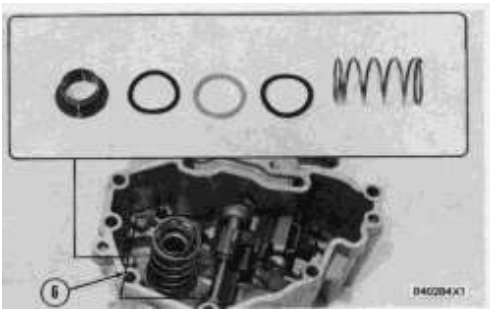

3. Remove governor spring (6), the two wave washers, one flatwasher and seat from the guide in the housing.

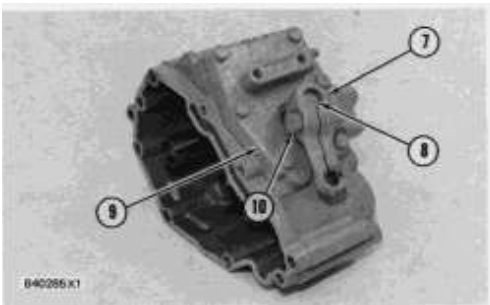

4. Make a mark of the position of lever (7) on shaft (8). Loosen bolt (10). Use a chisel or screwdriver to expand expansion of lever (7) so it can be removed from shaft (8).

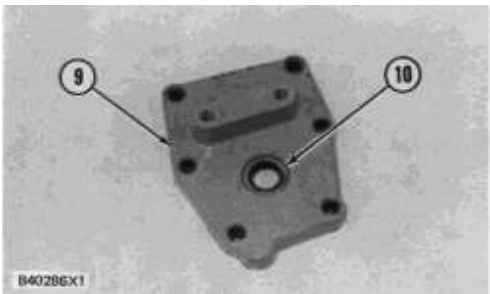

5. Remove cover assembly (9).

6. Use tooling (A) to remove seal (10) from cover (9).

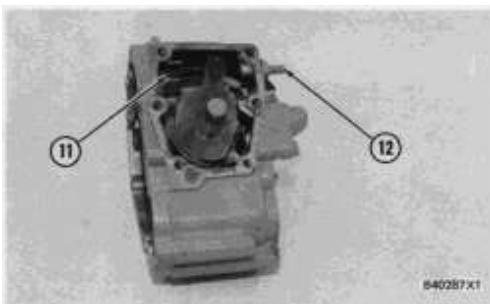

7. Remove low idle adjustment screw (12) and spring (11) from the housing.

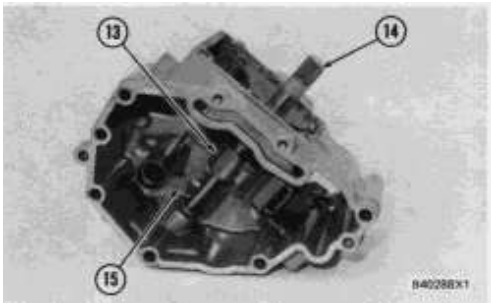

8. Remove shaft assembly (14), lever (13) and lever (15) from the housing.

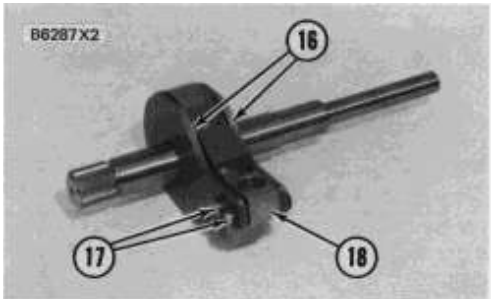

9. Remove two snap rings from pins (17), and remove pins (17). Remove plates (16) and stop (18) from the shaft assembly.

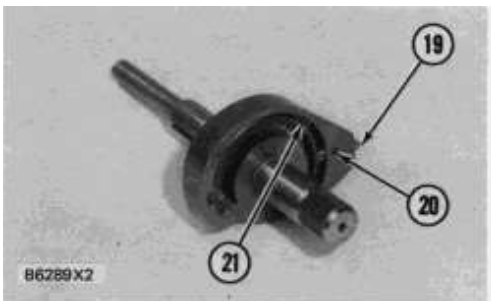

10. Remove pin (20), pin (19) and spring (21) from the shaft assembly.

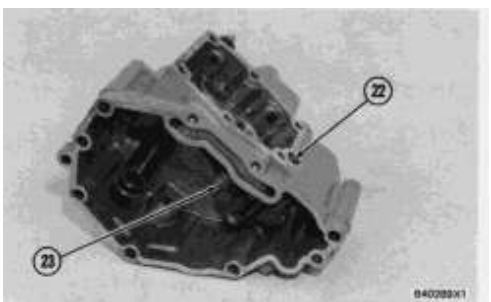

11. Remove shaft (22) and lever (23) from the housing.

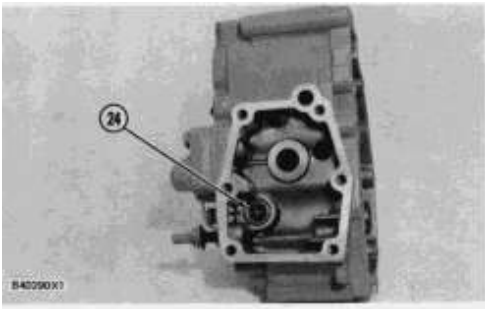

---

## NOTICE

**Remove check valve (24) only if a replacement is necessary because the check valve will be damaged during removal.**

---

12. Remove check valve (24) if a replacement is necessary.

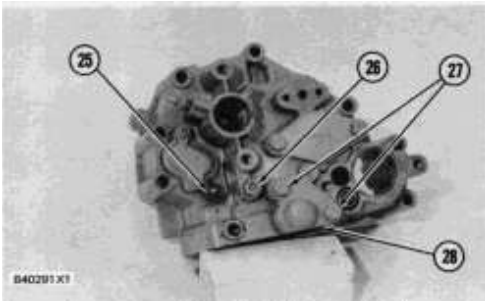

13. Remove contact (25) and body (26) for the governor dashpot adjustment screw from the housing. Remove bolts (27), cover (28) and the gasket from the housing.

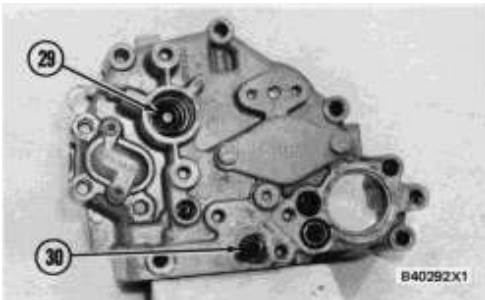

14. Remove seal (29) and adjustment screw (30) for high idle.



15. Remove two bolts (31), housing (32) and the gasket from the fuel injection pump housing.

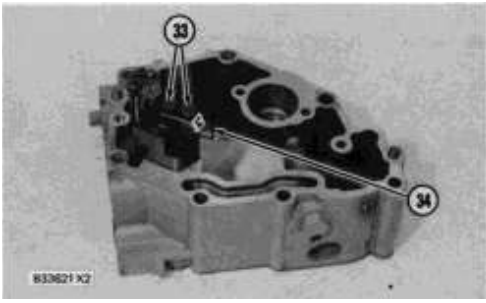

16. Remove bolts (33) and torque control group (34).

17. Disassemble the torque control group and inspect the spacer, spring and insulator for damage or wear.

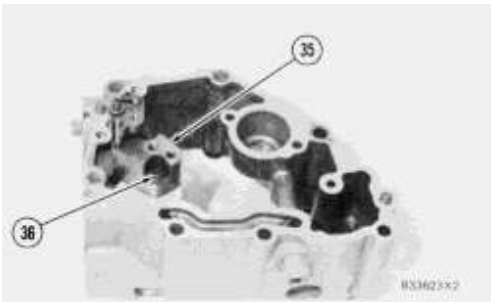

18. Remove bolts (36) and block (35) for the full load stop from the housing.

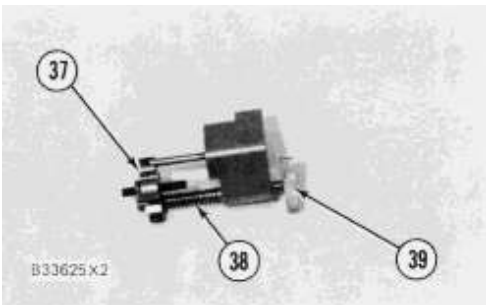

19. Remove the bolt that holds collar (37) to bolt (39). Remove collar (37) and spring (38) from bolt (39). Remove bolt (39) from the block.

20. Remove the stop screw from collar (37) if a replacement is necessary.

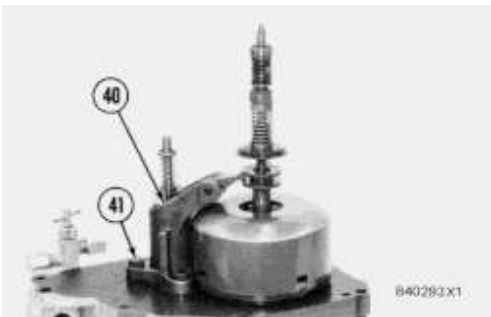

21. Remove bolts (41) and governor servo (40) from the fuel injection pump.

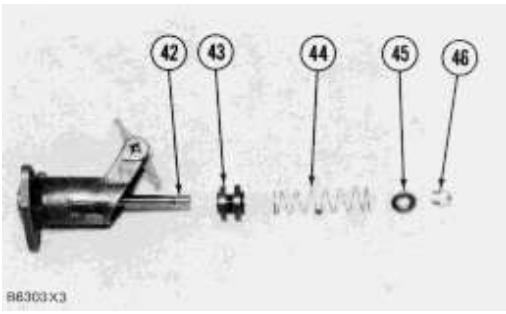

**22.** Remove lockring (46), seat (45), spring (broken link spring) (44) and sleeve (43) from valve (42). Remove the other lockring (46) from the groove in the center of valve (42).

**NOTE:** The groove in the bottom of valve (42) must be in alignment with the servo body to permit removal from the fuel rack.

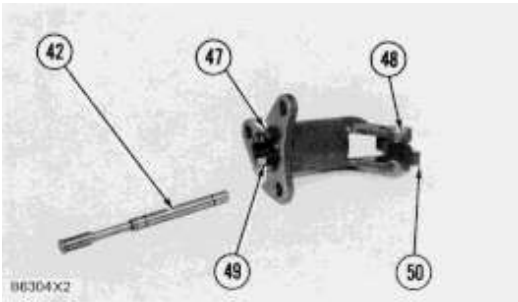

**23.** Remove valve (42), sleeve (47) and piston (49) from the governor servo. Remove the O-ring seal from sleeve (47).

**24.** Remove pin (48) and lever (50) from the governor servo.

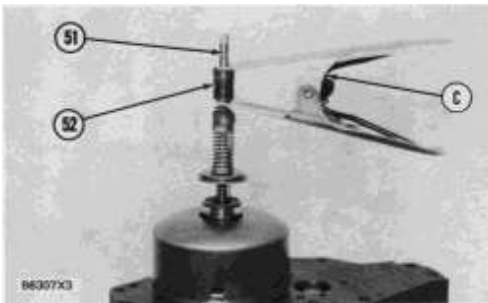

**25.** Use tool (C) to hold spring (52) in compression so ring (51) can be removed. Spring (52) is used to put a preload on the thrust bearing for the camshaft in the fuel injection pump housing.

**26.** Remove ring (51); then remove tool (C).

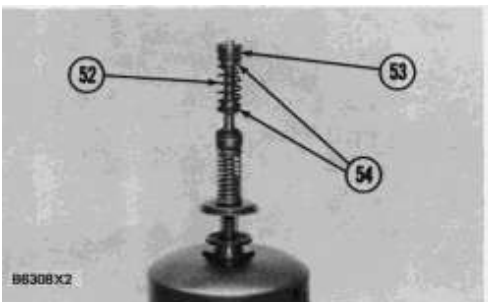

**27.** Remove bearing (53), sleeves (54) and spring (52) from the governor shaft.

Thank you so much for reading.  
Please click the “Buy Now!”  
button below to download the  
complete manual.



After you pay.

You can download the most  
perfect and complete manual in  
the world immediately.

Our support email:

[ebooklibonline@outlook.com](mailto:ebooklibonline@outlook.com)