

JOHN DEERE
AG & TURF DIVISION

John Deere Tractors
100 Series

OMGX24230 H1

OPERATOR'S MANUAL



JOHN DEERE

North American Version
Printed in U.S.A.

Introduction

⚠ WARNING: The Engine Exhaust from this product contains chemicals known to the State of California to cause cancer, birth defects or other reproductive harm.

California Proposition 65 Warning

Table of Contents

| | |
|------------------------------|----|
| Introduction..... | 1 |
| Product Identification..... | 1 |
| Safety Labels..... | 3 |
| Safety..... | 9 |
| Machine Cleanout..... | 12 |
| Assembly..... | 15 |
| Operating Controls..... | 17 |
| Operating..... | 20 |
| Service Intervals..... | 30 |
| Service Lubrication..... | 31 |
| Service Engine..... | 32 |
| Service Transmission..... | 38 |
| Service Mower..... | 38 |
| Service Electrical..... | 43 |
| Service Miscellaneous..... | 45 |
| Troubleshooting..... | 48 |
| Storage..... | 50 |
| Specifications..... | 51 |
| Warranty..... | 54 |
| Index..... | 56 |
| Getting Quality Service..... | 57 |
| Service Record..... | 59 |

Introduction

Thank You for Purchasing a John Deere Product

We appreciate having you as a customer and wish you many years of safe and satisfied use of your machine.

Using Your Operator's Manual

This manual is an important part of your machine and should remain with the machine when you sell it.

Reading your operator's manual will help you and others avoid personal injury or damage to the machine. Information given in this manual will provide the operator with the safest and most effective use of the machine. Knowing how to operate this machine safely and correctly will allow you to train others who may operate this machine.

This manual and safety signs on your machine may also be available in other languages (see your authorized dealer to order).

Sections in your operator's manual are placed in a specific order to help you understand all the safety messages and learn the controls so you can operate this machine safely. You can also use this manual to answer any specific operating or servicing questions.

The machine shown in this manual may differ slightly from your machine, but will be similar enough to help you understand our instructions.

RIGHT-HAND and LEFT-HAND sides are determined by facing in the direction the machine will travel when going forward. When you see a broken line (-----), the item referred to is hidden from view.

Before delivering this machine, your dealer performed a predelivery inspection to ensure best performance.

Special Messages

Your manual contains special messages to bring attention to potential safety concerns, machine damage as well as helpful operating and servicing information. Please read all the information carefully to avoid injury and machine damage.



CAUTION: Avoid injury! This symbol and text highlight potential hazards or death to the operator or bystanders that may occur if the hazards or procedures are ignored.

IMPORTANT: Avoid damage! This text is used to tell the operator of actions or conditions that might result in damage to the machine.

NOTE: General information is given throughout the manual that may help the operator in the operation or service of the machine.

Product Identification

Record Identification Numbers

Lawn Tractors

D100, D110, D120, D130, D140, D160, D170

PIN (200001-) 49 State

PIN (020001-) California

PIN (060001-) Australia, Canada, Mexico, ROW.

If you need to contact an Authorized Service Center for information on servicing, always provide the product model and identification numbers.

You will need to locate the product identification number (PIN) for the machine and engine serial number. Record the information in the spaces provided below.

Original Instruction
All information, illustrations and specifications in this manual are based on the latest information at the time of publication. The right is reserved to make changes at any time without notice.

COPYRIGHT© 2011
Deere & Co.
John Deere Ag & Turf Division
All rights reserved
Previous Editions
COPYRIGHT© 2009, 2010, 2011

Product Identification

DATE OF PURCHASE:

DEALER NAME:

DEALER PHONE:

PRODUCT IDENTIFICATION NUMBER:

ENGINE SERIAL NUMBER:

Machine Product Identification Number Location



MX46486

Picture Note: Located on left side of frame.

Engine Serial Number Location

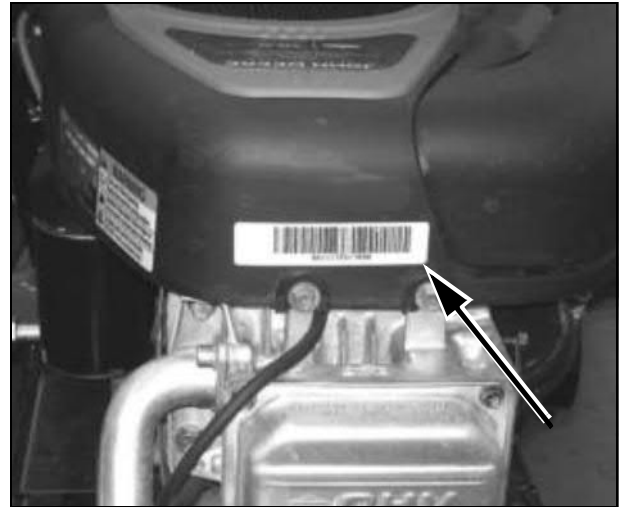

MX25599

Picture Note: Single Cylinder Engines

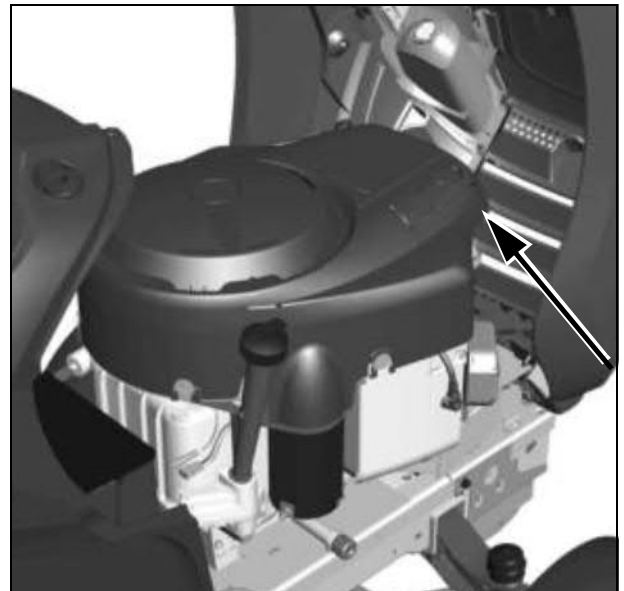

MX49394

Picture Note: V-Twin Engines

Register Your Product and Warranty Online

To register your product through the Internet, simply go to www.JohnDeereWarrantyRegistration.com. Completing the information, either online or with the product warranty card, will ensure the customer that their product receives all post sales service and important product information.

Safety Labels

Safety Label Location (Text)

Safety Labels

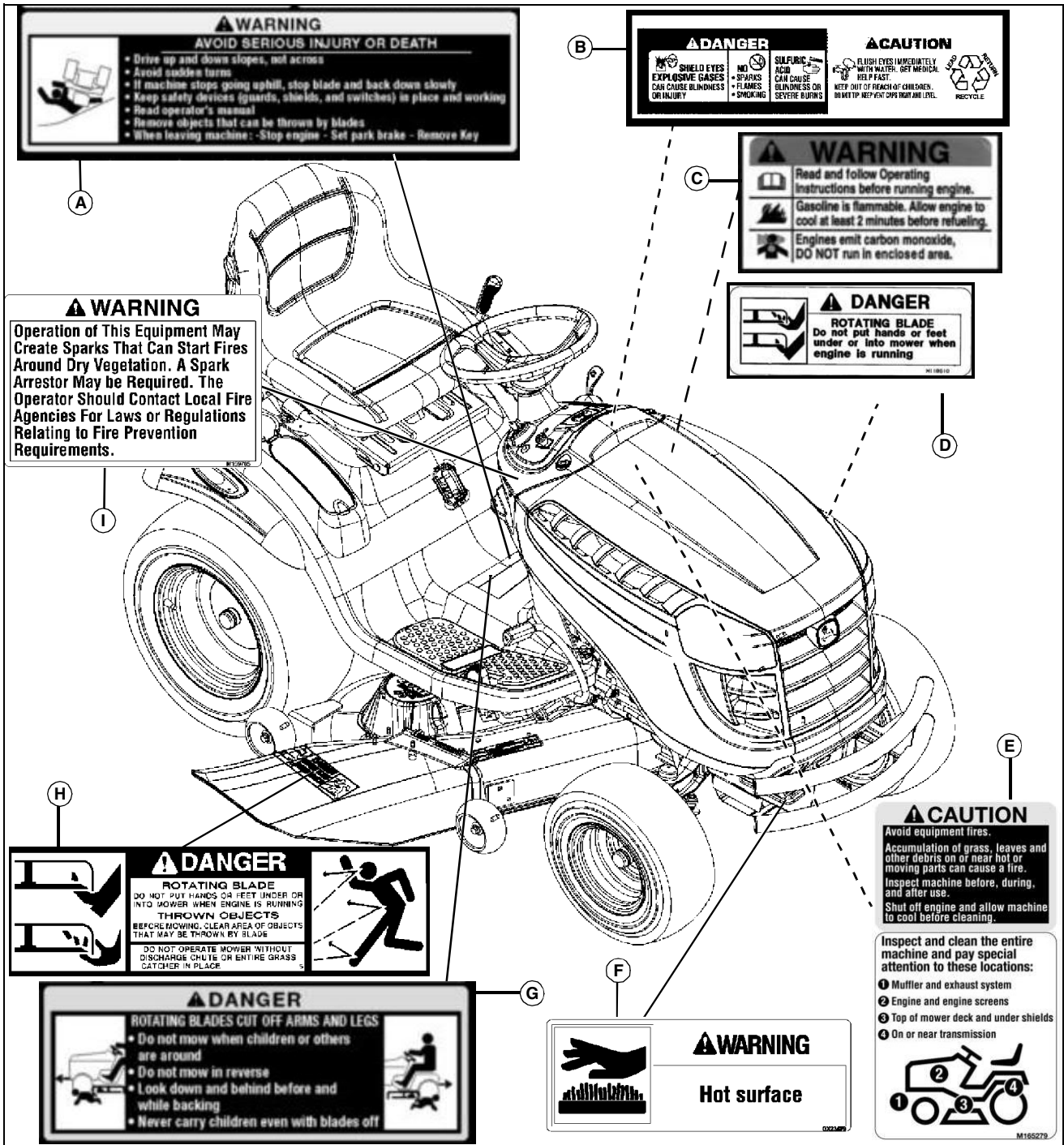

MX46490

F- WARNING GX23479

G- DANGER GX22477

H- DANGER M89504

I - WARNING M159705

Picture Note: Use label number listed in table below to locate complete text of safety label message following this illustration.

A- WARNING GX22477

B- DANGER/CAUTION M128699

C- WARNING MX4878

D- DANGER M118610

E- CAUTION M165279

Safety Labels

Safety Label Location (No Text)

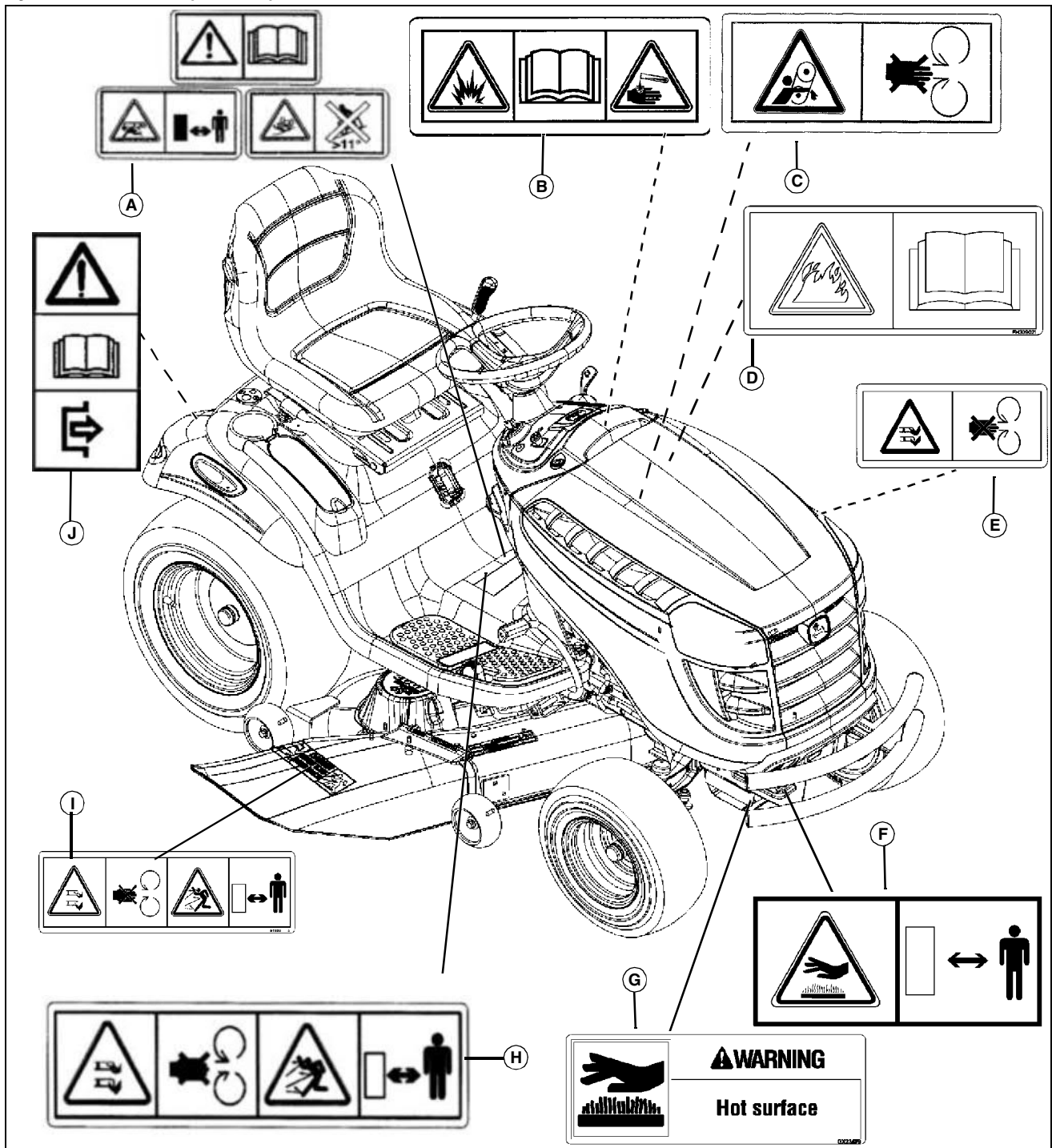

MX46490

Picture Note: Non-text labels are required for certain regions of the world. Your machine may not be equipped with these labels. Use label number listed in table below to locate complete text of safety label message following this illustration.

- A- WARNING GX21000
- B- WARNING M128484
- C- WARNING M136436
- D- CAUTION FH309021

- E- DANGER M118041
- F- WARNING GX21121
- G- WARNING GX23479
- H- DANGER M148522
- I - DANGER M118040
- J- WARNING (Bypass Lever) GX21086

Thank you so much for reading.
Please click the “Buy Now!”
button below to download the
complete manual.



After you pay.

You can download the most
perfect and complete manual in
the world immediately.

Our support email:

ebooklibonline@outlook.com