

535 Log Loader



**OPERATOR'S
MANUAL**



**John Deere Dubuque Works
OMT186071 K0**

Sections

Section	Description
1	Introduction
2	Warranty
3	Safety
4	Description
5	Operation
6	Lubrication & Maintenance
7	Troubleshooting
8	Specifications
9	S240/S260/S261 Slashers Operator's Manual Section
10	D250 Delimber Operator's Manual Section

Appendices

A	Metric & Imperial Unit Expressions
B	Measurement Conversions
C	Wood Measurement
D	Weights of Commercial Woods
E	General Bolt Torque Values
F	Abbreviations
	Checklists

Contents

Section 1 – Introduction

.1	Foreword	1-1
.2	Model & Serial Number Record	1-2
.3	Installation	1-4

Section 2 – Warranty

2-1

Section 3 – Safety

3-1

.1	Safety Signs	3-20
----	--------------------	------

Contents

Section 4 – Description

.1	Introduction	4-1
.2	Equipment Nomenclature	4-2
.3	Controls & Instrumentation	4-4
.1	Switches, Gauges & Indicators	4-4
	Master Disconnect Switch	4-4
	Engine Gauges	4-4
	Ignition Key Switch	4-5
	Throttle Control	4-5
	Horn	4-6
	Switches	4-7
	Indicators	4-8
.2	Operating Controls	4-9
	Swing Control	4-9
	Joysticks	4-9
.3	Miscellaneous Items	4-10
	Interior Light	4-10
	Cab Fan	4-10
	Seat	4-11

Section 5 – Operation

.1	Engine	5-1
.1	Pre-Start Checks	5-1
.2	Throttle Speed Switch	5-2
.3	Starting/Stopping	5-2
	Normal Starting	5-2
	Cold Weather Starting	5-2
	Using Battery Charger	5-3
.4	Cold Weather Warm-Up	5-3
.5	Idling	5-3
.6	Stopping the Engine	5-4
.2	Loader	5-4
.1	Stabilizers	5-4
.2	Turntable Rotation	5-5
.3	Implements	5-5
.1	Joystick Controls	5-5
.4	Transporting	5-7
.5	535 Main Boom Lowering	5-8

Contents

Section 6 - Lubrication & Maintenance

.1	Maintenance Schedule	6-1
.2	Engine Enclosure Raising and Lowering	6-4
.3	Engine Enclosure Hand Pump Operation	6-5
.4	Maintenance Procedures	6-6
.1	Every 8 Hours	6-6
.2	Every 50 Hours	6-12
.3	Every 100 Hours	6-14
.4	Every 250 Hours	6-17
.5	Every 500 Hours	6-20
.6	Every 2000 Hours	6-21
.7	Unscheduled	6-25
.5	Fluids & Lubricants	6-27
.1	Specifications	6-27
.2	Diesel Engine Oil	6-28
.3	Swing Drive Oil	6-29
.4	Hydraulic System Oil	6-30
.5	Diesel Fuel	6-31
.6	Diesel Engine Coolant	6-32
.7	Grease	6-33
.6	Lubrication Chart	6-34

Contents

Section 7 – Troubleshooting

.1	General	7-2
.1	Guide to Diagnostic Charts	7-3
.2	Engine	7-4
.1	Starting Problems	7-4
.2	Hard (or No) Start With Exhaust Smoke	7-5
.3	Hard (or No) Start without Exhaust Smoke	7-6
.4	Engine Starts but Stalls	7-7
.5	Overheating	7-9
.6	Low Oil Pressure	7-11
.7	Excessive Oil Pressure	7-12
.3	Electrical System	7-13
.1	Complete System Failure	7-13
.2	Batteries Not Charging	7-14
.3	Starter Motor Inoperative	7-15
.4	Inoperative AC	7-16
.5	Inoperative Accessories	7-17
.4	Hydraulic System	7-18
.1	Complete System Failure	7-18
.2	Slow Cylinder Operation	7-19
.3	Fluid Temperature Too High	7-20
.4	Fluid Foams	7-21
.5	System Noise	7-21

Section 8 – Specifications

.1	Envelope	8-1
.2	Specifications	8-3

Contents

Section 9 – S240/S260/S261 Slashers Operator’s Manual Section

.1	Introduction	1-1
.1	Model & Serial Numbers	1-1
.2	Warranty	2-1
.1	Statement	2-1
.2	Exclusions	2-2
.3	Description	3-1
.1	Overview	3-1
.4	Operation	4-1
.1	Basic	4-1

Contents

Section 10 – D250 Delimber Operator’s Manual Section

.1	Introduction1-1
.1	Model & Serial Number Record1-1
.2	Warranty	2-1
.1	Statement2-1
.2	Exclusions2-2
.3	Description	3-1
.1	Overview	3-1
.4	Operation	4-1
.1	Overview	4-1

Contents

Appendices

A	Metric & Imperial Unit Expressions	Appendices-1
B	Measurement Conversions	Appendices-2
C	Wood Measurement	Appendices-4
D	Weights of Commercial Woods	Appendices-5
E	General Bolt-Torque Values	Appendices-6
F	Abbreviations	Appendices-7
	Checklists	CLIS-1

1. Introduction

.1 Foreword

READ THIS MANUAL carefully to learn how to operate and service your machine correctly. Failure to do so could result in personal injury or equipment damage. This manual and safety signs on your machine may also be available in other languages. (See your John Deere dealer to order.)

THIS MANUAL SHOULD BE CONSIDERED a permanent part of your machine and should remain with the machine when you sell it.

MEASUREMENTS in this manual are given in both metric and customary U.S. unit equivalents. Use only correct replacement parts and fasteners. Metric and inch fasteners may require metric or inch wrench.

RIGHT-HAND AND LEFT-HAND sides are determined by facing in the direction of forward travel.

WRITE PRODUCT IDENTIFICATION NUMBERS (P.I.N.) in the Machine Numbers section. Accurately record all the numbers to help in tracing the machine should it be stolen. Your dealer also needs these numbers when you order parts. File the

identification numbers in a secure place off the machine.

WARRANTY is provided as part of John Deere's support program for customers who operate and maintain their equipment as described in this manual. The warranty is explained on the warranty certificate which you should have received from your dealer.

This warranty provides you the assurance that John Deere will back its products where defects appear within the warranty period. In some circumstances, John Deere also provides field improvements, often without charge to the customer, even if the product is out of warranty. Should the equipment be abused, or modified to change its performance beyond the original factory specifications, the warranty will become void and field improvements may be denied. Setting fuel delivery above specifications or otherwise overpowering machines will result in such action.

THE TIRE MANUFACTURER'S warranty supplied with your machine may not apply outside the U.S.

CALIFORNIA PROPOSITION 65 WARNING

Diesel engine exhaust and some of its constituents are known to the State of California to cause cancer, birth defects and other reproductive harm.

1. Introduction (continued)

.2 Model & Serial Number Record

To properly identify your specific machine and its components when communicating with your John Deere Dealer, please record the model and serial numbers below and refer to them when ordering service or replacement parts.

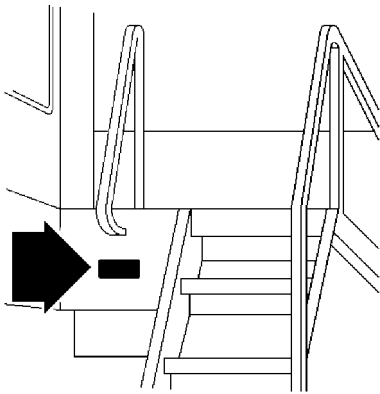

TJ147

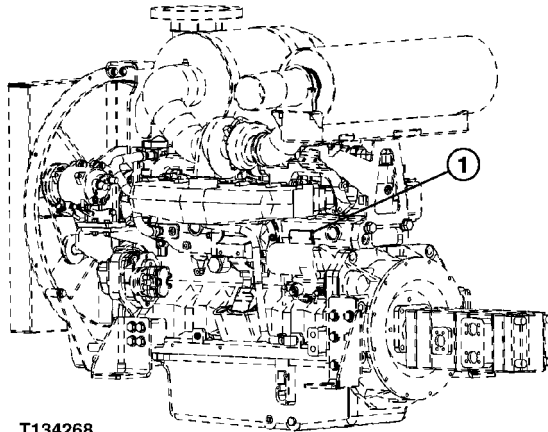

T134268

Loader:

Model Number: _____

Serial Number: _____

Engine:

Model Number: _____

Serial Number: _____

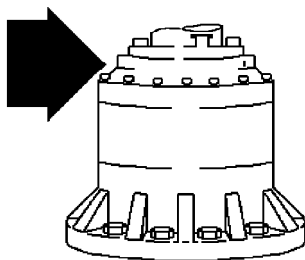

TJ148

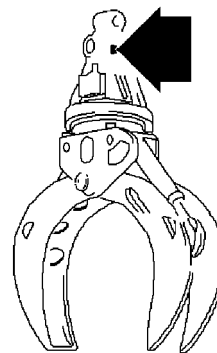

TJ149

Swing Drive Gearbox:

Model Number: _____

Serial Number: _____

Grapple:

Model Number: _____

Serial Number: _____

1. Introduction (continued)

.2 Model & Serial Number Record (continued)

To properly identify your specific machine and its components when communicating with your John Deere Dealer, please record the model and serial numbers below and refer to them when ordering service or replacement parts.

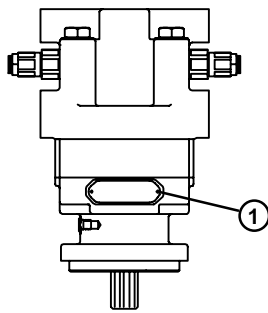

T134872

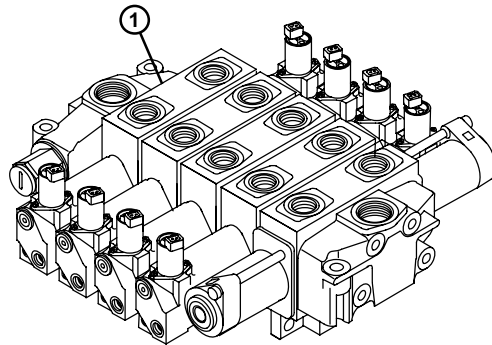

TJ299

Swing Motor:

Model Number: _____

Serial Number: _____

Swing Valve:

Model Number: _____

Serial Number: _____

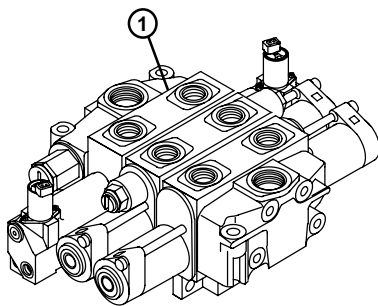

TJ300

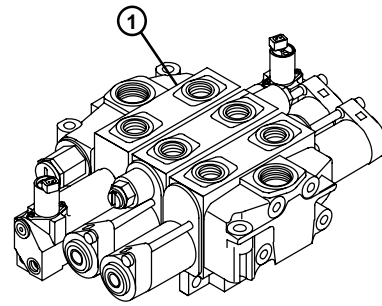

TJ290

Main Boom Valve:

Model Number: _____

Serial Number: _____

Jib Boom Valve:

Model Number: _____

Serial Number: _____

1. Introduction (continued)

.3 Installation

When mounting the loader on a common type trailer or truck frame, use the hardware kits provided with the loader.

Shown below, the loader is installed on an I-beam type vehicle frame (either truck or trailer), however, the same installation may also be applied to U-channel type vehicle frames.

- 1) Position the loader on the vehicle frame.
- 2) Attach the loader base to the vehicle frame in four locations, ensuring that each clamping kit is installed as shown.

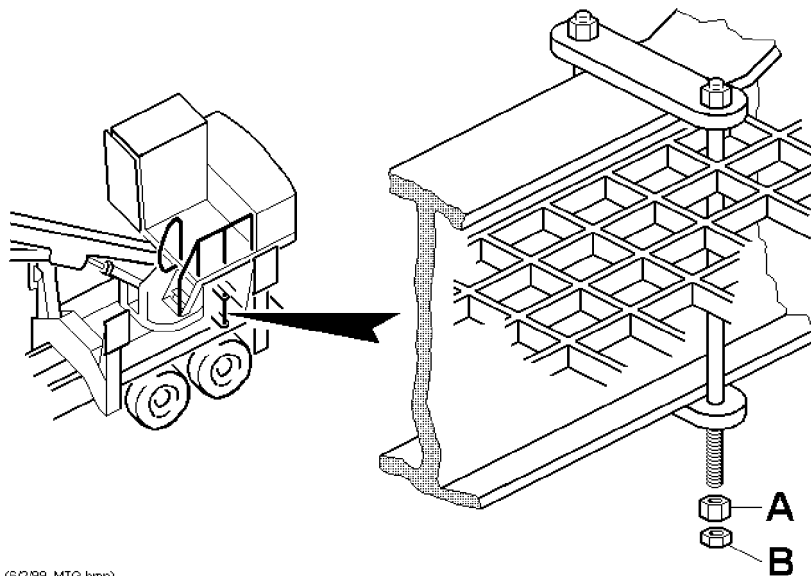

(5/2/99 MTG.bmp)

NOTE: When installing the loader on a U-channel type vehicle frame, a spacer plate may be required between the open ends of the U-channel at each clamping location to prevent distortion when the clamps are tightened.

- 3) Torque the clamp nut (**A**) to 725-800 ft. lb. (3219-3552 Nm) at each location.
- 4) Install, and tighten, the jam nut (**B**) at each location.

2. Warranty

EMISSIONS CONTROL WARRANTY STATEMENT FOR NEW JOHN DEERE CONSTRUCTION EQUIPMENT (U.S. AND CANADA)

To determine if the engine in your machine qualifies for the additional warranties set forth below, look for the "Engine Information" label located on your engine. If you reside in the United States and the engine label states: "Engine conforms to US EPA regulations on heavy duty non road diesel cycle engines," you are entitled to the "U.S. Emission Control Warranty Statement." If you reside in California, and the engine label states: "Engine conforms to California regulations on heavy duty non road diesel cycle engines," you are entitled to the "California Emission Control Warranty Statement."

U.S. EPA EMISSIONS CONTROL WARRANTY STATEMENT

Emissions control-related parts and components are warranted by John Deere for five years or 3000 hours of operation, whichever occurs first. John Deere further warrants that the engine covered by this warranty was designed, built, and equipped so as to conform at the time of sale with all U.S. emissions standards at the time of manufacture, and that it is free of defects in materials and workmanship which would cause it not to meet these standards within the period of five years or 3000 hours of operations, whichever occurs first.

Warranties stated on this certificate refer only to emissions-related parts and components of your engine. The complete machine warranty, less emissions-related parts and components, is provided separately as "John Deere "Secure Warranty" For New Construction Products."

CALIFORNIA EMISSION CONTROL WARRANTY STATEMENT YOUR WARRANTY RIGHTS AND OBLIGATIONS

The California Air Resources Board (CARB) and John Deere are pleased to explain the emission control system on your new engine. In California, new heavy-duty engines must be designed, built and equipped to meet the State's stringent anti-smog standards. John Deere must warrant the emission control system on your engine for the periods of time listed below provided there has been no abuse, neglect, or improper maintenance of your machine.

Your emissions control system includes:

- Fuel Metering System
- Fuel Injection System

- Air Induction System
- Intake Manifold
- Turbocharger System
- Charge Air Cooling System

- Miscellaneous Items used in Above Systems

Where a warrantable condition exists, i.e. failure due to defect in John Deere-supplied material and/or workmanship, John Deere will repair your heavy-duty engine at no cost to you including diagnosis, parts and labor

JOHN DEERE'S WARRANTY COVERAGE:

The emission control system of your heavy-duty engine is warranted for five years or 3000 hours of operation, whichever occurs first. If any emission-related part on your engine is defective, the part will be repaired or replaced by John Deere. Warranties stated on this certificate refer only to emissions-related parts and components of your engine. The complete machine warranty, less emissions-related parts and components, is provided separately as the "John Deere "Secure Warranty" For New Construction Products."

OWNER'S WARRANTY RESPONSIBILITIES:

As the heavy-duty engine owner, you are responsible for the performance of the required maintenance as outlined in the

Operator's Manual. John Deere recommends that you retain all receipts covering maintenance on your heavy-duty engine, but John Deere cannot deny warranty solely for the lack of receipts or for your failure to ensure the performance of all scheduled maintenance.

However, as the heavy-duty engine owner, you should be aware that John Deere may deny you warranty coverage if your heavy-duty engine or a part has failed due to abuse, neglect, improper maintenance or unapproved modifications.

Your engine is designed to operate on diesel fuel only. Use of any other fuel may result in your engine no longer operating in compliance with California's emissions requirements.

You are responsible for initiating the warranty process. The CARB suggests that you present your machine to the nearest authorized John Deere dealer as soon as a problem is suspected. The warranty repairs should be completed by the service dealer as expeditiously as possible.

If you have any questions regarding your warranty rights and responsibilities, you should contact John Deere at 1-319-292-5400, or the State of California Air Resources Board, Mobile Source Operation Division, PO Box 8001, El Monte, CA 91731-2900

The warranty period begins on the date the machine is delivered to an ultimate purchaser, or when otherwise put into service. John Deere warrants to the ultimate purchaser and each subsequent purchaser that the engine is designed, built and equipped so as to conform with all applicable regulations adopted by the Air Resources Board, and that it is free from defects in materials and workmanship which would cause the failure of a warranted part.

Any warranted part which is scheduled for replacement as required maintenance by the operator's manual is warranted by John Deere for the period of time prior to the first scheduled replacement point for that part. If the part fails prior to the first scheduled replacement point, the part shall be repaired or replaced under warranty. Any such part repaired or replaced under warranty is warranted for the remainder of the period prior to the first scheduled replacement point for that part.

Any warranted part which is not scheduled for replacement as required maintenance, or which is scheduled only for regular inspection to the effect of repairing or replacing as necessary, is warranted for the warranty period.

Repair or replacement of a warranted part will be performed at no charge to you by an authorized John Deere dealer. You will not be charged for diagnostic labor which leads to the determination that a warranted part is defective, if the diagnostic work is performed by a John Deere dealer.

John Deere is liable for damages to other engine components caused by failure under warranty of any warranted part.

John Deere is NOT liable for travel or mileage on extended emissions warranty service calls.

Any replacement part may be used in the performance of any maintenance or repairs, and such use will not reduce the warranty obligations of John Deere. However, the use of add-on or modified parts are grounds for disallowing a warranty claim.

Buy Now



Our support email:

ebooklibonline@outlook.com