

1118_RE506218_PCD

1118 VALVE COVER

KEY	PART NO.	PART NAME	QTY	REMARKS	
1	H23125	PLUG	4		
2	R123574	NUT	4		
3	R123575	O-RING	4		
4	RE502969	VALVE COVER	1	MARKED R519779	
5	R524480	GASKET	1		

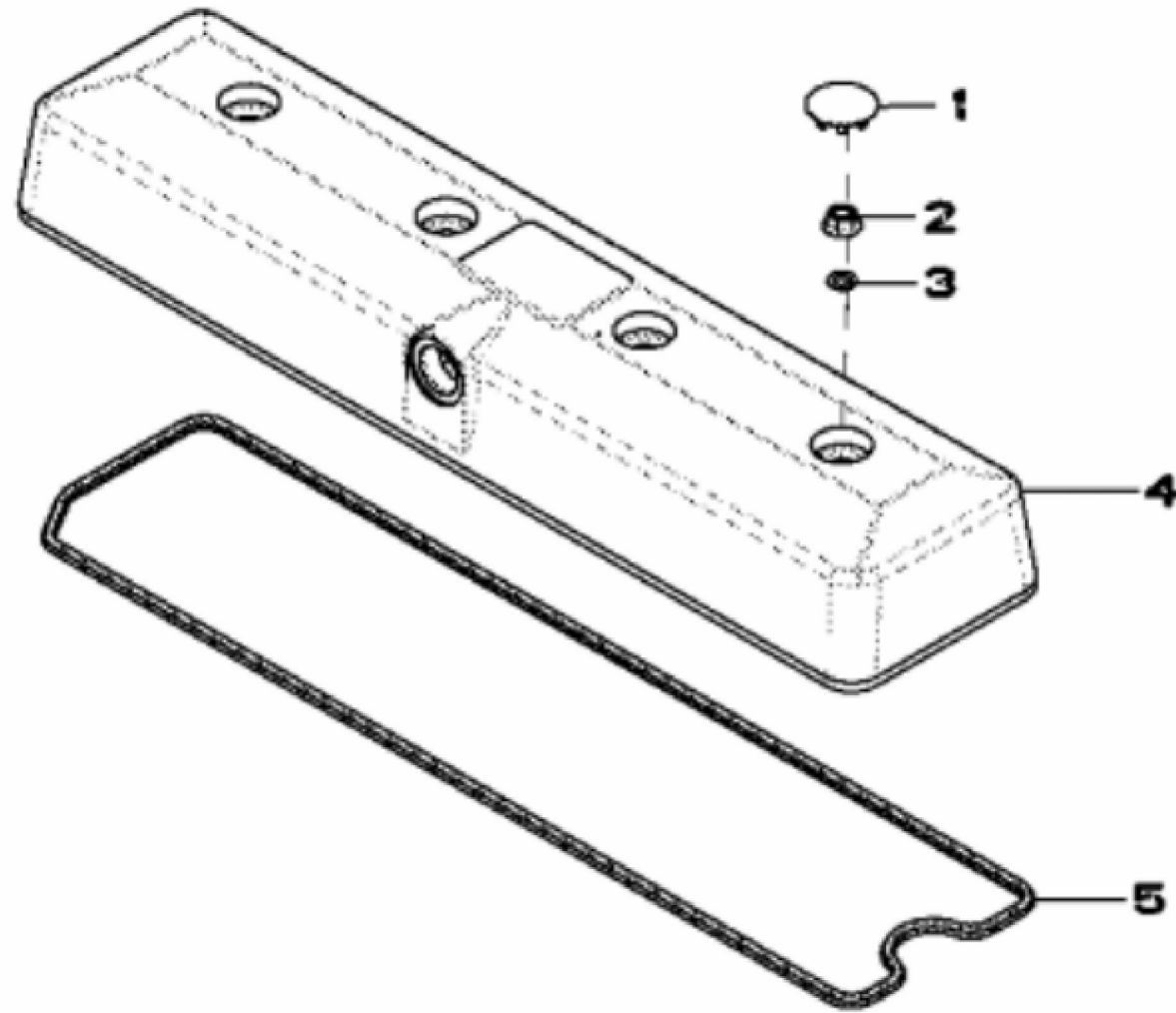

RE519871PCDB01

1127 VALVE COVER

KEY	PART NO.	PART NAME	QTY	Engine Serial No.	REMARKS	
1	H23125	PLUG	4	____-126173		
2	R123574	NUT	4	____-126173		
3	R123575	O-RING	4	____-126173		
4	RE502969	VALVE COVER	1	____-126173	(Also Order R524480)	
5	R524480	GASKET	1	____-126173		

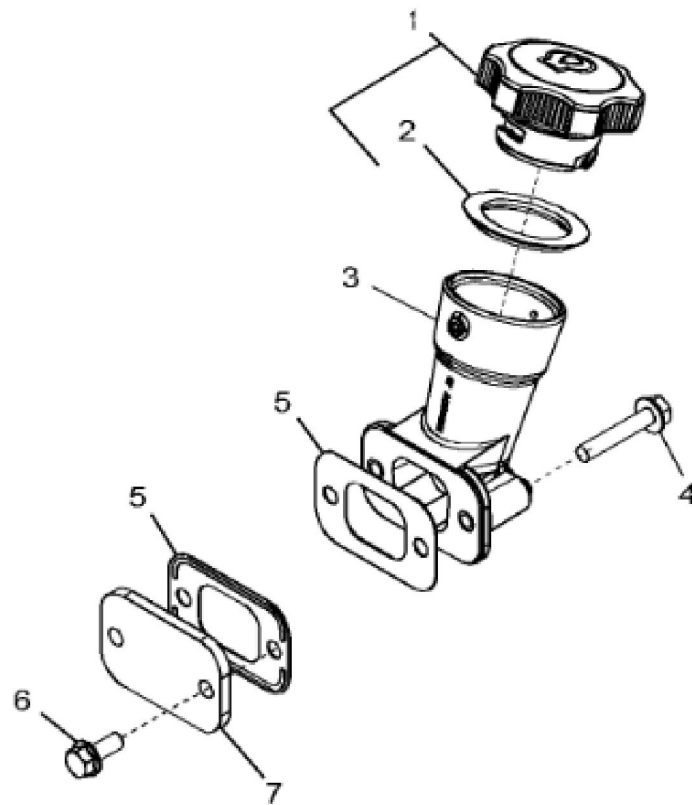

1202 OIL FILLER NECK

KEY	PART NO.	PART NAME	QTY	REMARKS	
1	RE500005	FILLER CAP	1	ORDER RE535560	
1	RE535560	FILLER CAP	1		
2	R502902	PACKING	1	ID= 44 mm, SUB FOR R500001	
3	RE501377	FILLER NECK	1	SUB FOR R136483	
4	RE67239	SCREW	2	(Threads With Pre-Applied Sealant)	
5	R136495	GASKET	2		
6	RE67238	SCREW	2	(Threads With Pre-Applied Sealant)	
7	R116296	COVER	1		

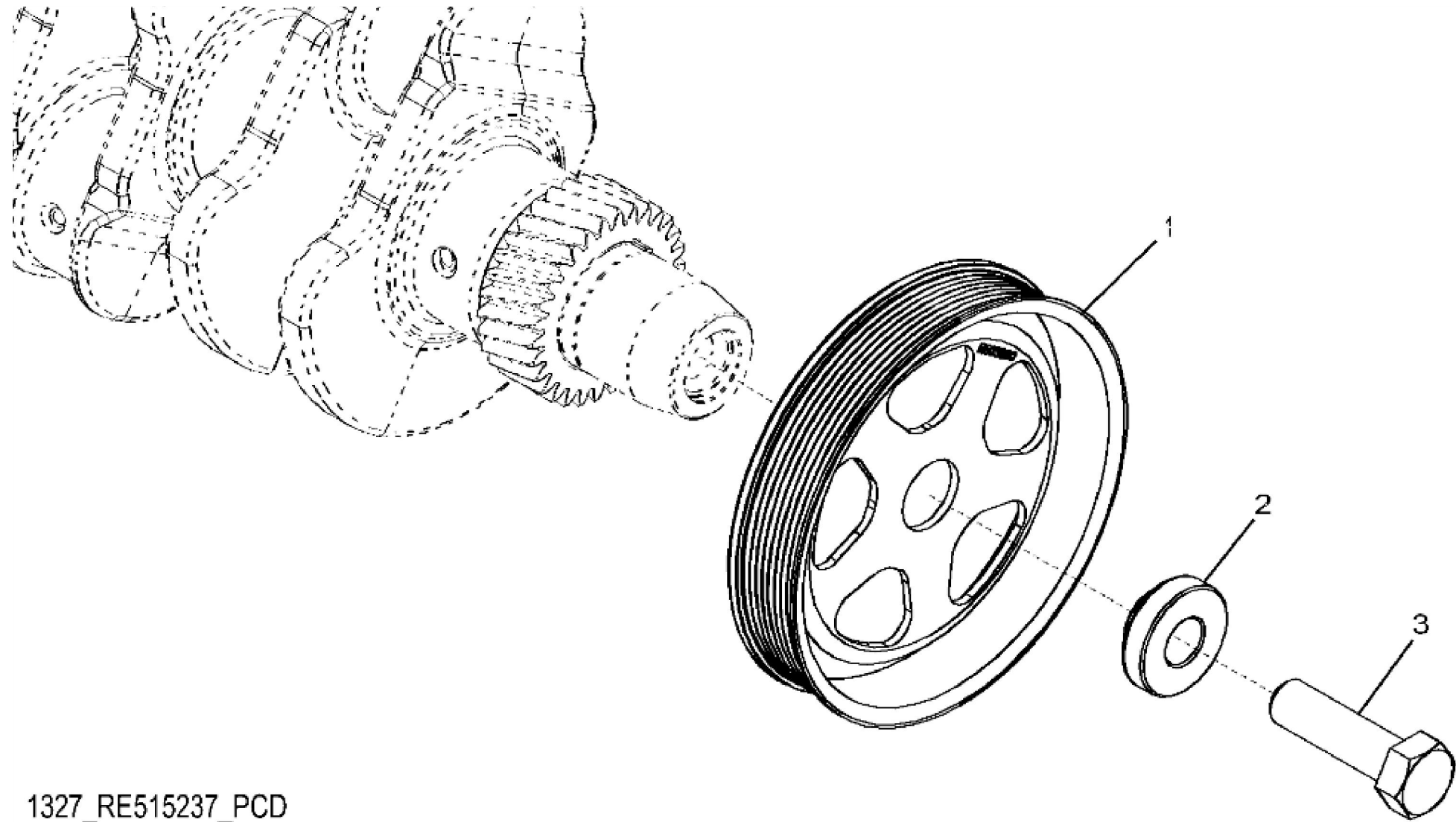

1327_RE515237_PCD

Thank you so much for reading.
Please click the “Buy Now!”
button below to download the
complete manual.



After you pay.

You can download the most
perfect and complete manual in
the world immediately.

Our support email:

ebooklibonline@outlook.com