

CD42516

John Deere > Turf And Utility >TRACTOR >5075E - TRACTOR >5045D, 5045E, 5055D, 5055E, 5065E, 5075E Tractors (Tier 2)(8X4 and 9X3 TSS Transmission with OOS)(North America Edition) >20 ENGINE 3029TPY30-RE538148 >ST639675 - BREATHER

KEY	PART NO.	PART NAME	QTY	ALL	REMARKS	
1	R56463	O-RING	1	X	21.819 X 3.531 mm (55/64" X 0.139")	
2	R92154	ELBOW FITTING	1	X		
3	TY22467	CLAMP	1	X	SUB FOR AT18904	
4	R516895	HOSE	1	X	LGTH = 889 mm	

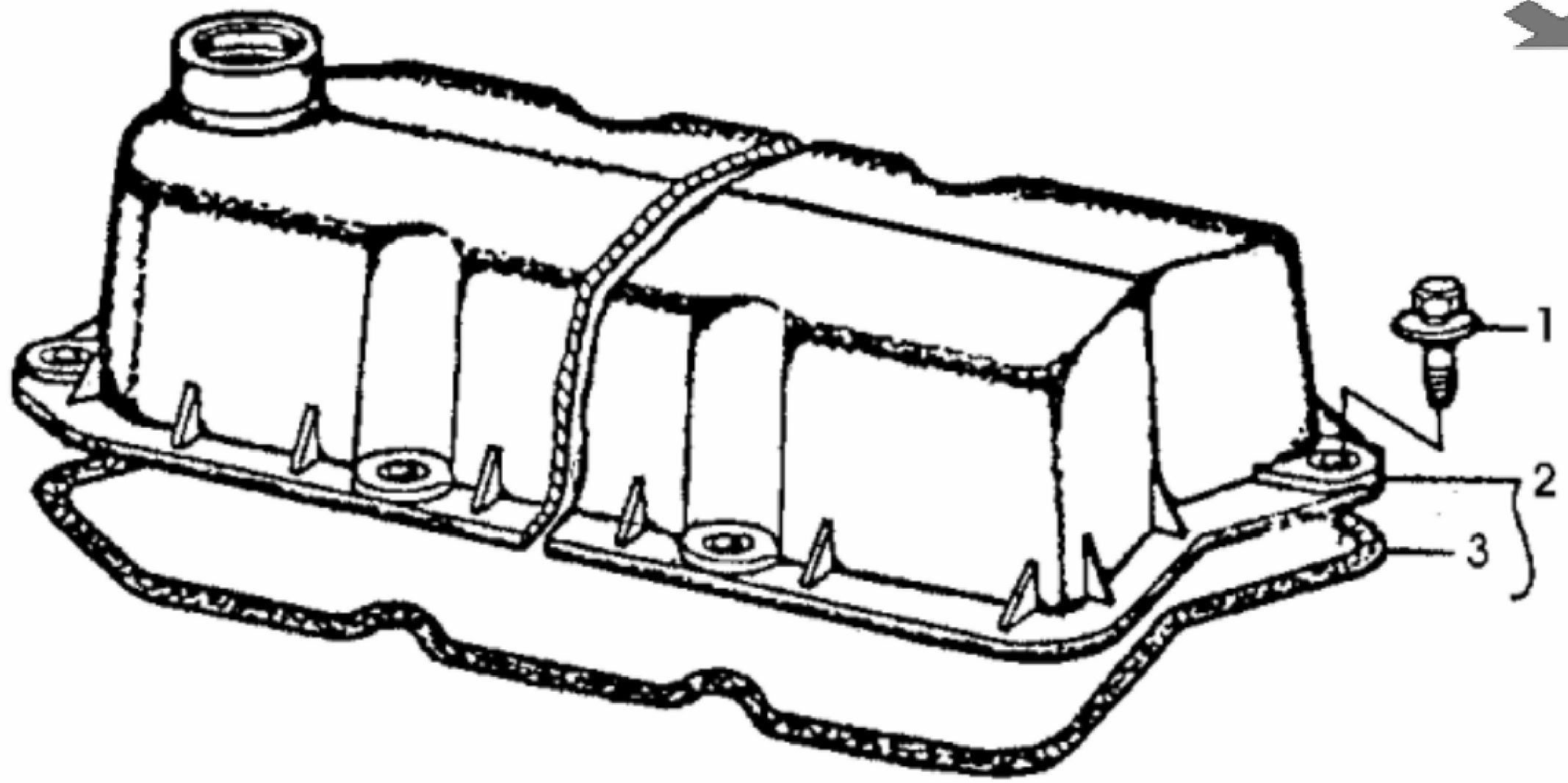

PY50072

John Deere > Turf And Utility > TRACTOR > 5075E - TRACTOR > 5045D, 5045E, 5055D, 5055E, 5065E, 5075E Tractors (Tier 2)(8X4 and 9X3 TSS Transmission with OOS)(North America Edition) > 20 ENGINE 3029TPY30-RE538148 > ST639676 - VALVE COVER

KEY	PART NO.	PART NAME	QTY	ALL	REMARKS	
1	RE32140	SCREW WITH WASHER	6	X		
2	RE515827	VALVE COVER	1	X		
3	R106796	O-RING	1	X	(CUT TO LENGTH, THIS APPLICATION ONLY)	

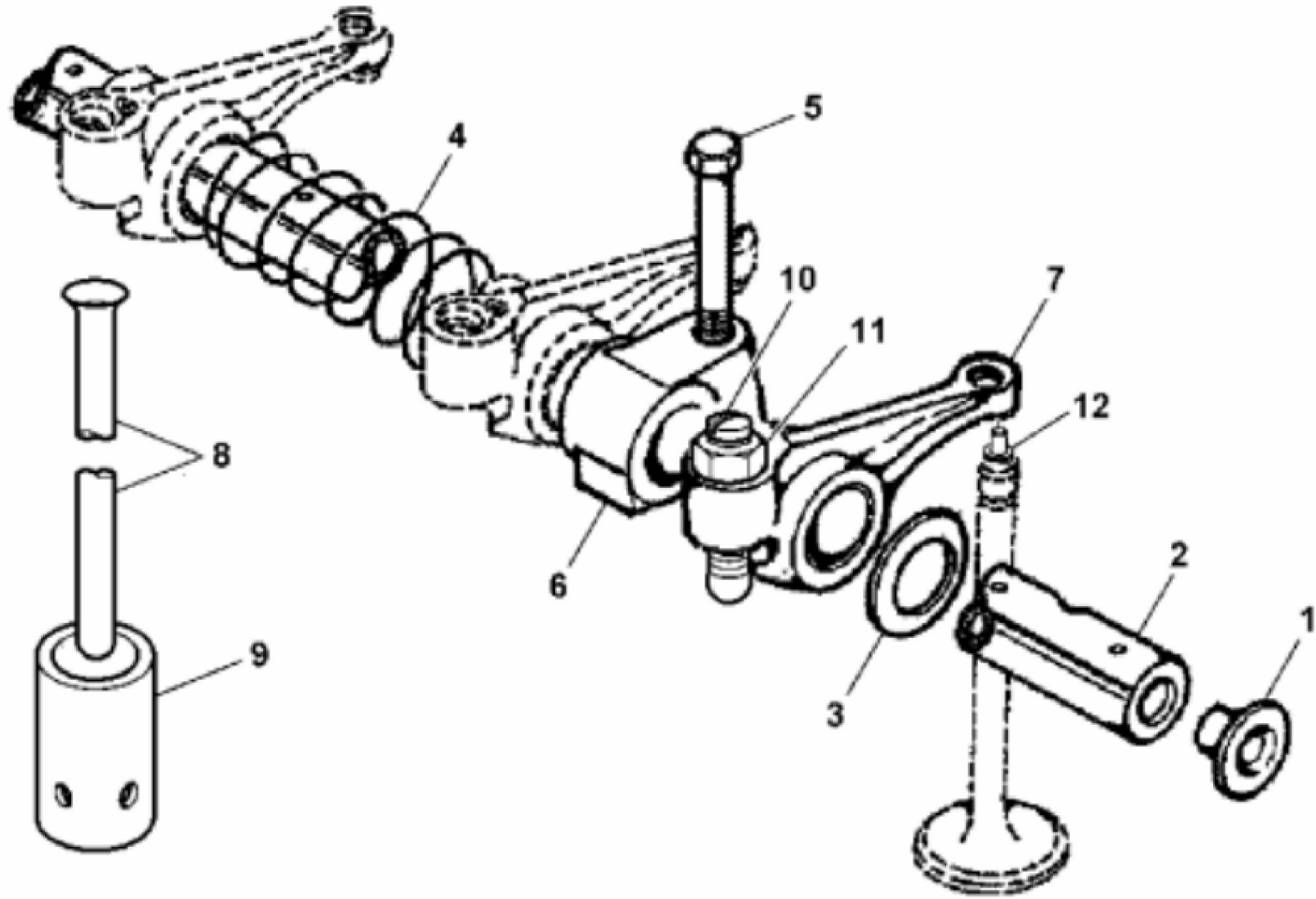

PY52171

3029TPY30-RE538148 > ST639677 - ROCKER ARM / SHAFT / TAPPET / PUSH ROD

KEY	PART NO.	PART NAME	QTY	ALL	REMARKS
1	R54565	PLUG	2	X	
2	R501532	SHAFT	1	X	
3	T20316	WASHER	2	X	
4	T20314	SPRING	2	X	
5	R504813	SELF-LOCKING SCREW	3	X	HS= 10.9; SAE 8
6	R123161	SUPPORT	3	X	SUB FOR R516741
7	RE62148	ROCKER ARM	6	X	
8	R515095	PUSH ROD	6	X	
9	R515092	CAM FOLLOWER	6	X	LGTH = 234 mm
10	R515577	SCREW	6	X	
11	R125881	LOCK NUT	6	X	
12	T26872	INSERT	6	X	

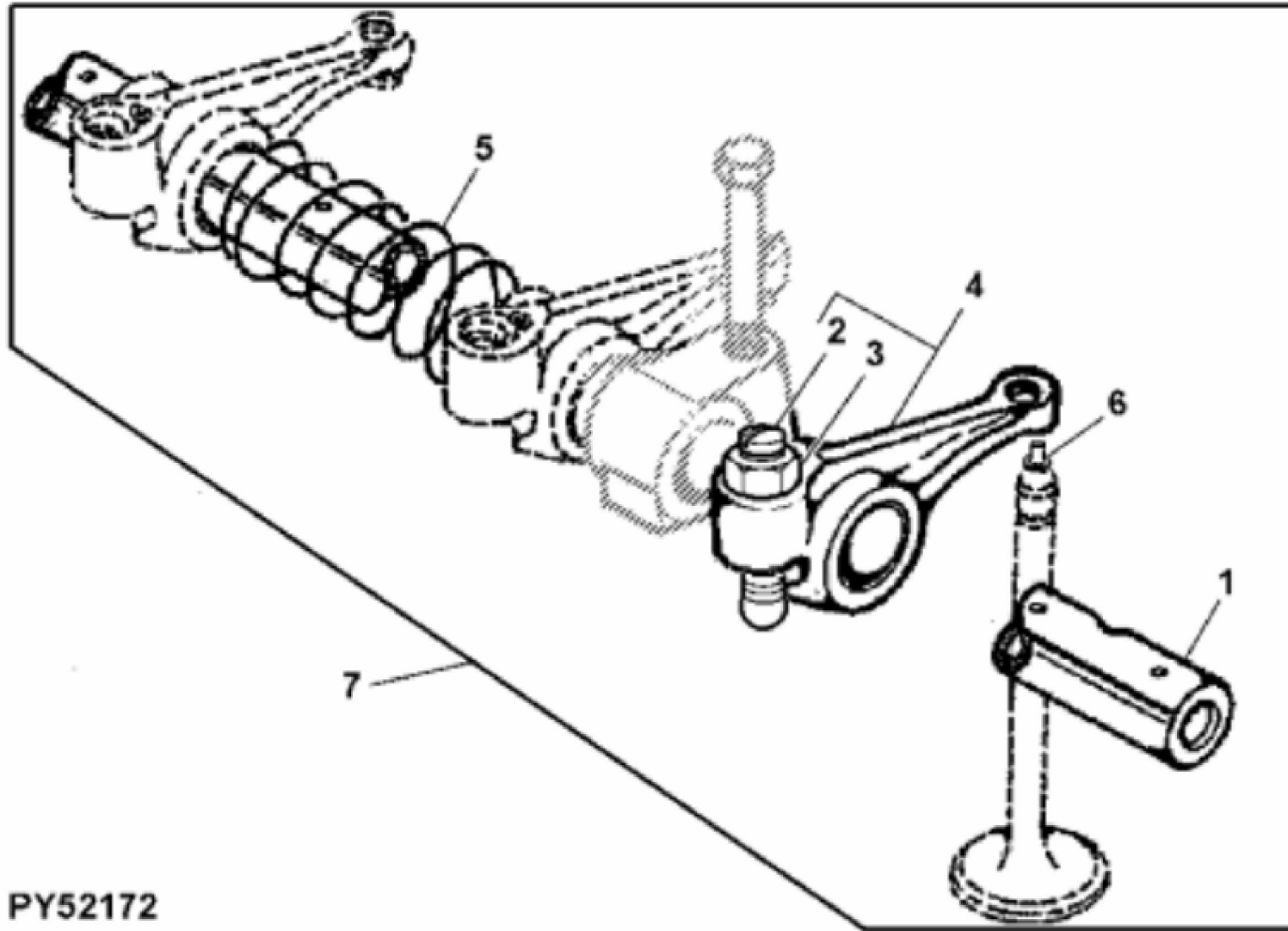

PY52172

Thank you so much for reading.
Please click the “Buy Now!”
button below to download the
complete manual.



After you pay.

You can download the most
perfect and complete manual in
the world immediately.

Our support email:

ebooklibonline@outlook.com