

**PY52958**

KEY	PART NO.	PART NAME	QTY	REMARKS	
1	R56463	O-RING	1		
2	R92154	ELBOW FITTING	1		
3	AT18904	CLAMP	1		
4	R526863	HOSE	1		

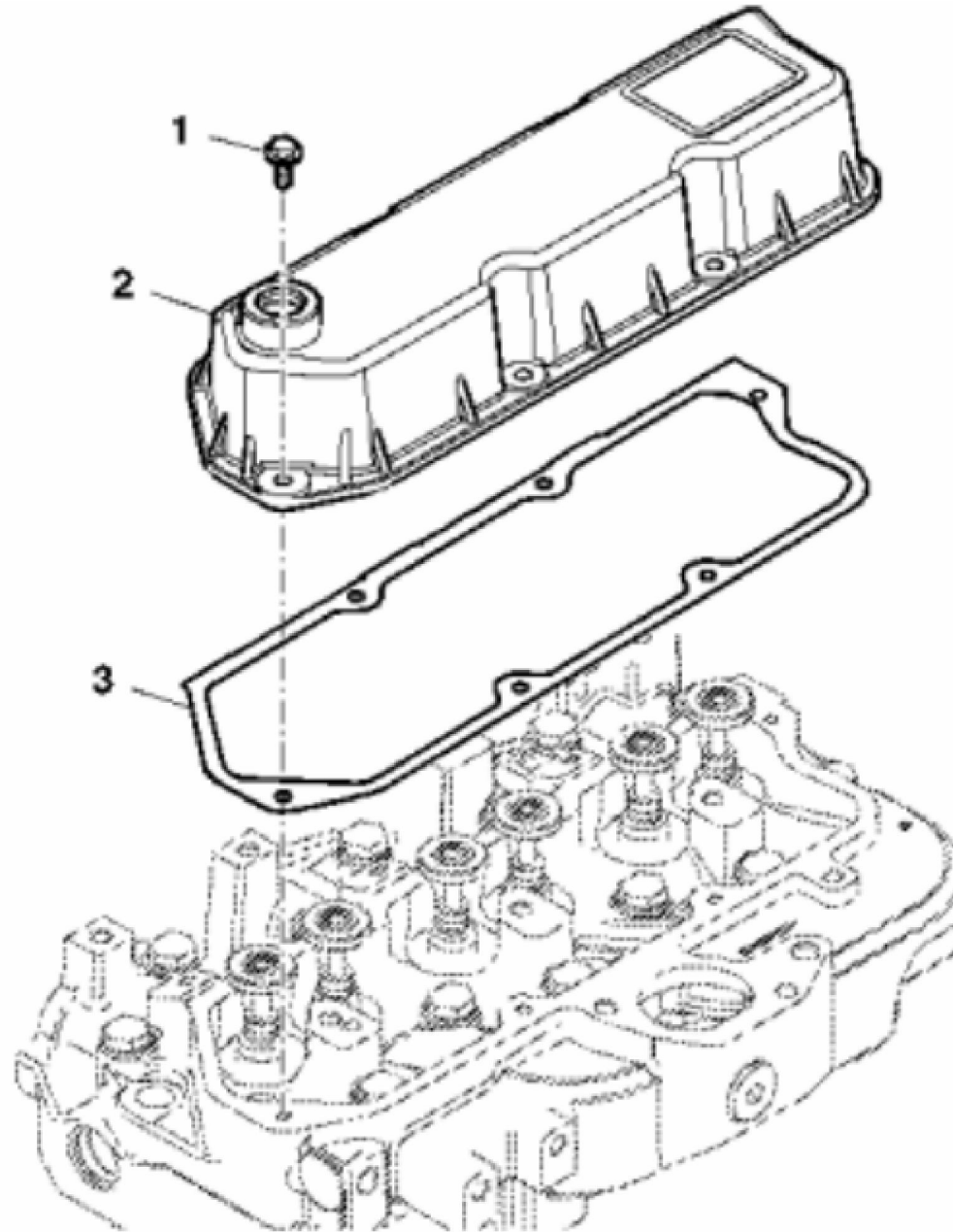

PY52959

KEY	PART NO.	PART NAME	QTY	REMARKS	
1	RE32140	SCREW WITH WASHER	6		
2	RE515827	VALVE COVER	1		
3	R106796	GASKET	1		

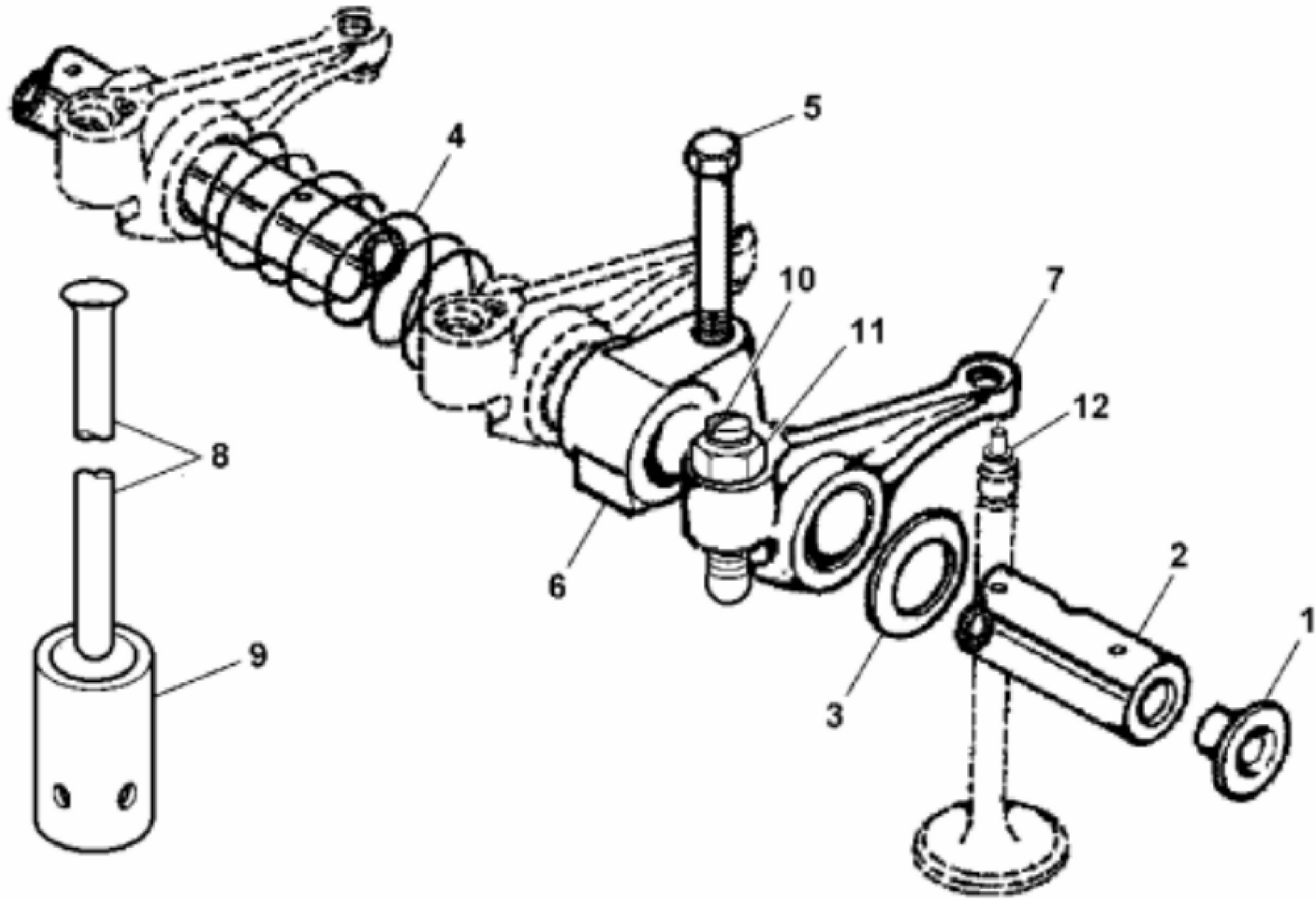

PY52171

John Deere > Turf And Utility >TRACTOR >5075E - TRACTOR >5055E, 5065E and 5075E Tractors (Tier3)(Europe/Australia Edition, 9X3 TSS Transmission W/ OOS) >20 ENGINE >ST356412 - ROCKER ARM SHAFT

KEY	PART NO.	PART NAME	QTY	REMARKS
1	R54565	PLUG	2	
2	.....	SHAFT	1	NLA; ORDER RE519735
2	RE519735	ROCKER ARM SHAFT	1	SUB FOR R501532
3	T20316	WASHER	2	
4	T20314	SPRING	2	
5	R504813	SELF-LOCKING SCREW	3	
6	R516741	SUPPORT	3	
7	RE62148	ROCKER ARM	6	
8	R515095	PUSH ROD	6	
9	R515092	CAM FOLLOWER	6	
10	R515577	SCREW	6	
11	R125881	LOCK NUT	6	
12	T26872	INSERT	6	

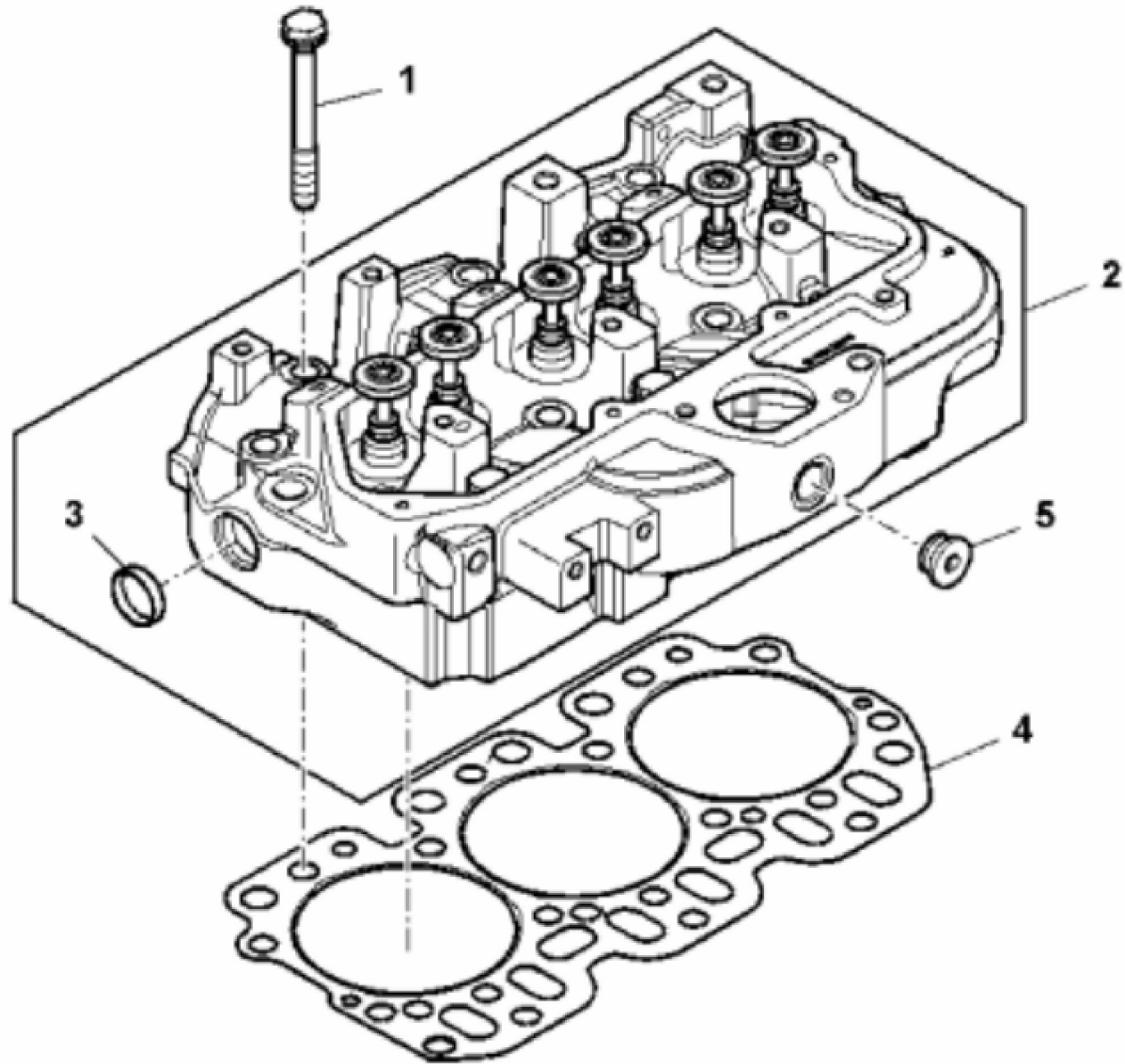

PY52960

Thank you so much for reading.  
Please click the “Buy Now!”  
button below to download the  
complete manual.



After you pay.

You can download the most  
perfect and complete manual in  
the world immediately.

Our support email:

[ebooklibonline@outlook.com](mailto:ebooklibonline@outlook.com)