

Section: ENGINE
CRANKCASE

Fig.	P/n	QTY	Name
------	-----	-----	------

Notes:
[674-70 N CROSS]

1	0.089.0050.6		gasket set - FOR ENGINE MOUNTING
2	2.1519.096.0/20	12	special oil seal 107.67x1.78 24943 <=
2	2.1539.193.0	8	special oil seal 107.62x2.62 => 24944
3	2.1559.188.0/10	4	bush
4	2.0432.003.7	12	stud bolt m 8 p.1.25 / p.1 x 20
5	0.009.7500.0/10	4	engine cylinder (...) <= A
5	0.011.0183.0/20	4	engine cylinder => 24944
5	0.011.0582.0	4	engine cylinder -> (...) = B 24943 <=
7	2.1549.154.2	4	bush 4.8x5.8x16
8	0.066.1130.0/20	1	flange
14	2.3199.405.2	1	plug m 28 p.1.5
15	2.1539.047.0	1	special oil seal 26.7x1.78
16	2.1099.108.2	4	special nut m 10 p.1
17	2.1560.006.0	8	gasket 10.2 x 16
18	0.086.1550.2	4	sprayer nozzle
19	0.065.1160.3/20	4	valve
20	2.3199.292.0	1	plug 1/4" gas
21	2.1560.010.0	1	gasket 14.2 x 20
24	0.066.1152.0/10	4	gasket
25	0.082.1110.6/20	1	crankcase * 24943 <= - N.4 011.0183.0/10 - N.8 2.1539.193.0
26	0.065.1112.7	1	support
27	2.1699.165.0	1	bush 12.3x15x16
28	0.065.1116.3	1	support
29	2.1699.165.0	1	bush 12.3x15x16
30	0.066.1151.0	1	pin
31	0.065.1141.0	1	special bushing 59X55X30
32	0.065.1140.0	4	special bushing 59X55X20
33	2.3179.012.0	1	plug 60
34	2.3130.001.1	11	plug 1/8" gas
35	2.3130.002.1	2	plug 1/4" gas
36	2.3130.003.1	5	plug 3/8" gas
37	2.1324.011.0	1	plug

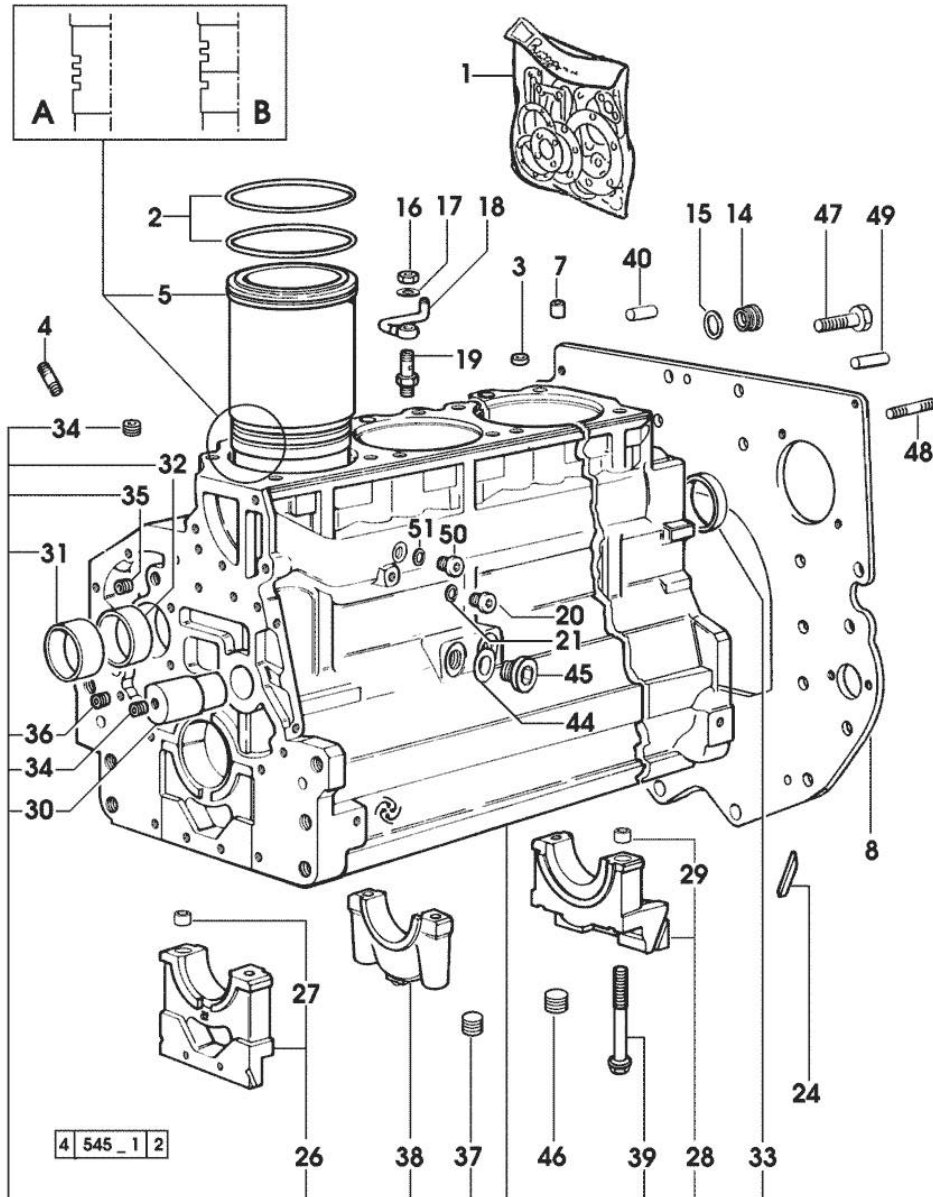

Section: ENGINE
CRANKCASE

Fig.	P/n	QTY	Name
38	0.065.1114.0/10	3	support
39	0.065.1117.0	10	screw m 12 x 100
40	2.1651.912.0	2	cylindrical plug 12x28
44	2.1560.017.0	1	gasket 22.2 x 27
45	2.3120.002.4	1	plug m 22 x 1.5
46	2.3130.003.1	2	plug 3/8" gas
47	2.0112.511.1	8	screw m 14 p.2 x 30
48	2.0432.255.7	2	stud bolt m 12 p.1.75-1.25x25
49	2.1651.917.0	1	cylindrical plug 12x40
50	2.3120.101.0	1	plug m 18 p.1.5 => 24944
51	2.1560.014.0	1	washer 18.2 x 24

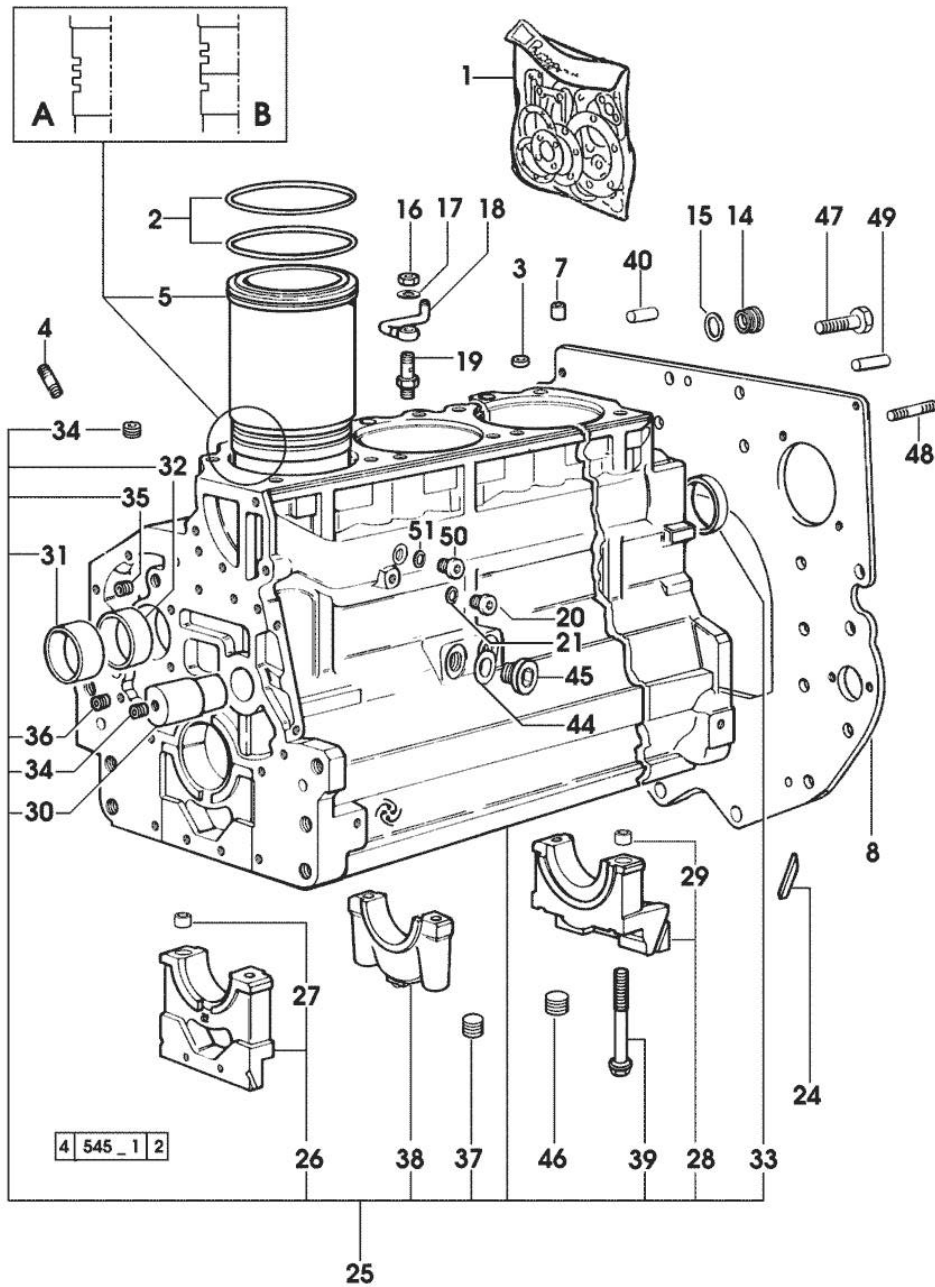

Section: ENGINE

TIMING CASE

Fig.	P/n	QTY	Name
------	-----	-----	------

Notes:

[674-70 N CROSS]

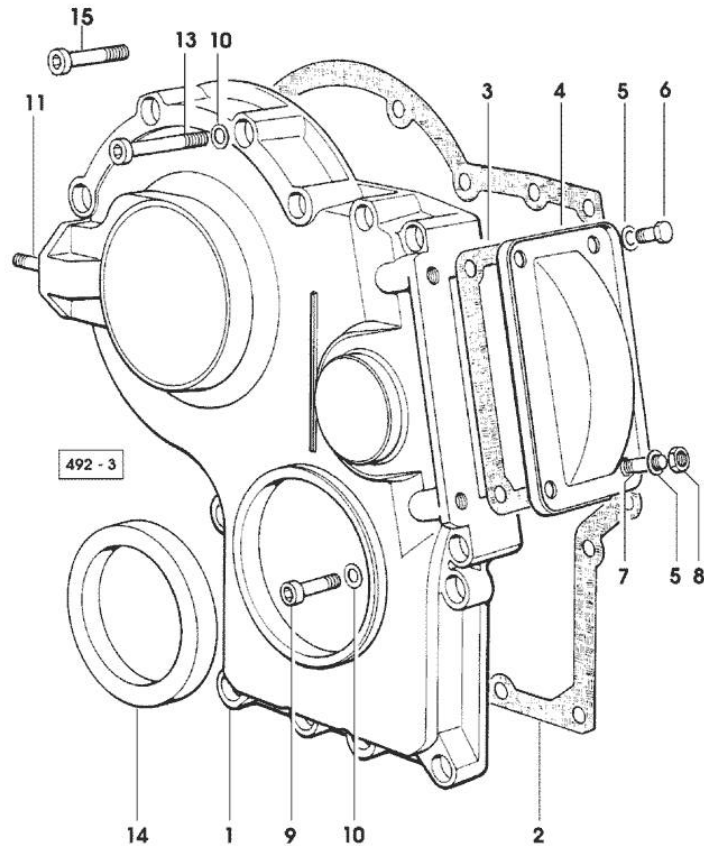

1	0.065.1132.0/60	1	guard
2	0.065.1150.0/30	1	gasket
3	0.065.1152.0	1	gasket
4	0.065.1151.0	1	cover
5	2.1470.004.2	4	lock washer 8
6	2.0112.205.2	2	screw m 8 p.1.25 x 16
7	2.0432.003.7	2	stud bolt m 8 p.1.25 / p.1 x 20
8	2.1011.405.2	2	nut m 8 p.1
9	2.0312.208.2	8	screw m 8 p.1.25 x 25
10	2.1480.014.1	15	washer 8
11	2.0432.003.7	2	stud bolt m 8 p.1.25 / p.1 x 20
13	2.0312.214.1	3	screw m 8 p.1.25 x 40
14	2.1529.141.0	1	special oil seal
15	2.0312.219.2	4	screw m 8 p.1.25x65

Section: ENGINE

TIMING CASE

Fig.	P/n	QTY	Name
------	-----	-----	------

Notes:

[674-70 N CROSS]

1	0.007.1262.3/50	1	guard
2	0.007.1271.0/10	1	small column m 8 p.1.25 / L = mm 60
3	0.007.1272.0/10	2	small column m 8 p.1.25 / L = mm 50
5	2.1310.004.2	3	flat washer 8.4x17
7	2.0112.205.2	3	screw m 8 p.1.25 x 16

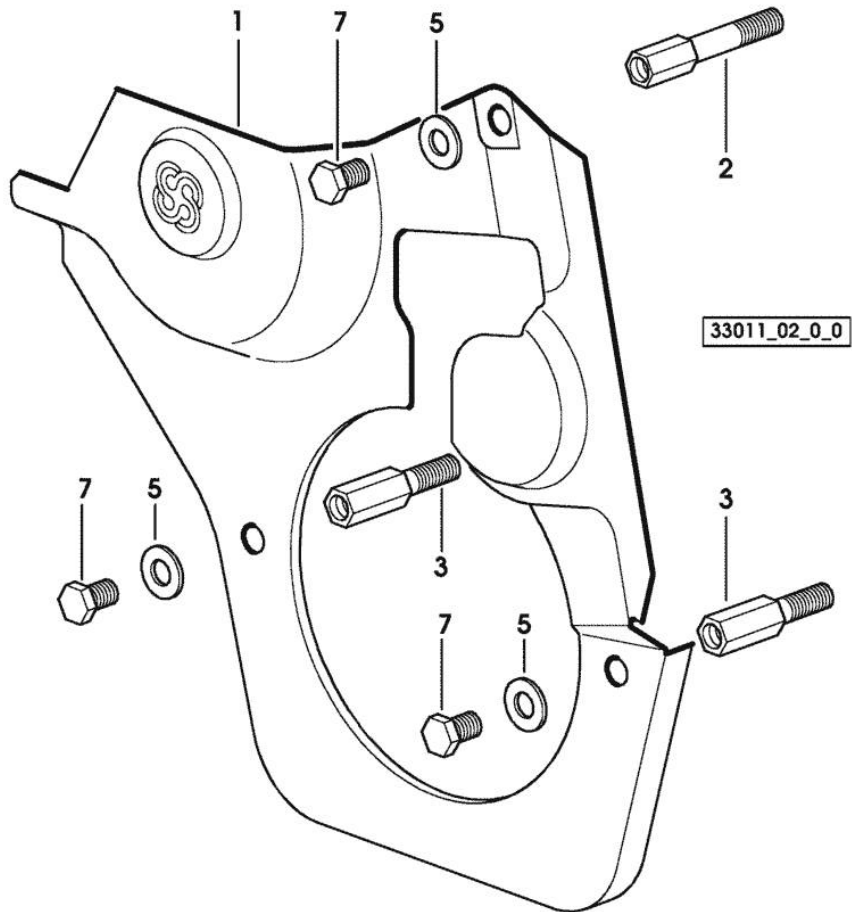

Section: ENGINE

CRANKSHAFT

Fig.	P/n	QTY	Name
------	-----	-----	------

Notes:

[674-70 N CROSS]

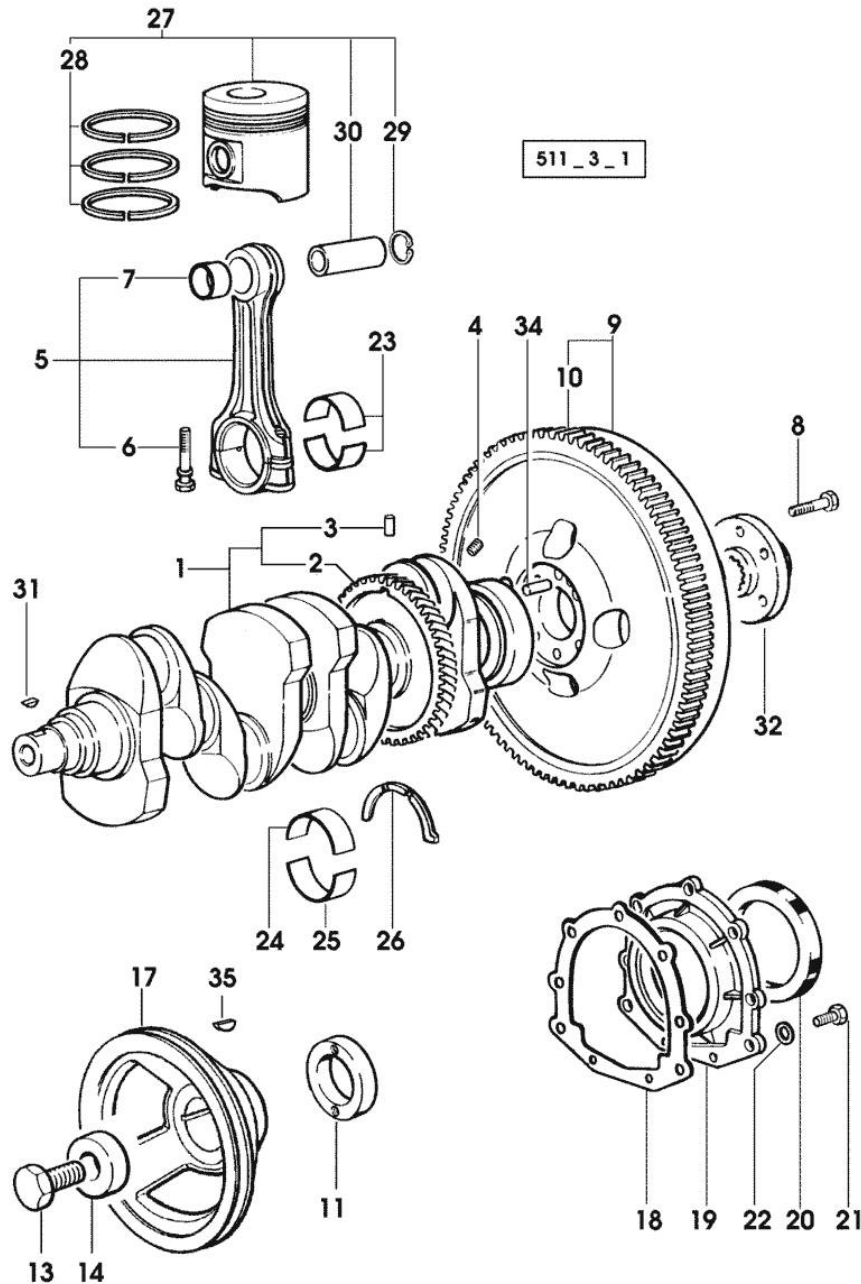

1	0.086.1210.3/30	1	crankshaft * 14871 <= - N.1 007.1711.0/10
2	0.065.1211.0/10	1	crown wheel
3	2.1630.608.0	1	pin 6x16
4	2.3130.001.1	4	plug 1/8" gas
5	0.078.1220.3/30	4	engine connecting rod
6	2.0399.213.0	8	screw m 12 p.1.25x61.5
7	2.1559.114.0/10	4	special bushing
8	2.0139.022.2	6	screw m 12 p.1.25x55
9	0.065.1247.3/30	1	flywheel
10	0.065.1242.0	1	crown wheel Z = 123
11	0.085.1248.0/10	1	hub
13	2.0399.144.7/10	1	screw m 20 p.1.5x51
14	2.1599.524.7	1	washer 21x60x12
17	0.007.1457.0/20	1	pulley * 13706 <= - N.1 2.1720.006.0
18	0.065.1254.0/20	1	gasket
19	0.007.1711.0/10	1	cover => 14872
19	0.065.1253.0/10	1	cover 14871 <=
20	2.1529.073.0	1	special oil seal 110x130x13
21	2.0112.207.2	9	screw m 8 p 1.25 x 20
22	2.1475.002.2	9	conical washer 8
23	0.065.1225.0	6	con.rod half bushing STANDARD - A = 28.75 -> 29.00
23	0.065.1225.7		con.rod half bushing - mm 0.25
23	0.065.1225.8		con.rod half bushing - mm 0.50
24	0.065.1215.0	4	main half bushing STANDARD
24	0.065.1215.7		main half bushing - mm 0.25
24	0.065.1215.8		main half bushing - mm 0.50
25	0.065.1216.0	4	main half bushing
25	0.065.1216.7		main half bushing - mm 0.25
25	0.065.1216.8		main half bushing - mm 0.50
26	0.065.1218.0	4	shim STANDARD
26	0.065.1218.7		shim + mm 0.10
26	0.065.1218.8		shim + mm 0.15
27	0.089.0060.6	4	complete piston
27	0.379.0060.6	4	complete piston - EXPORT U.S.A.

Section: ENGINE
CRANKSHAFT

Fig.	P/n	QTY	Name
28	0.086.0052.6/10	4	piston ring set
29	2.1411.014.1	8	circlip 35
30	0.078.1236.0	4	piston pin Ø 18 / Ø 35 / L = mm 86
31	2.1720.006.0	1	key 4x6.5
32	0.255.2525.0/10	1	flange
34	2.1652.915.0	1	cylindrical plug 12x35
35	2.1720.006.0	1	key 4x6.5

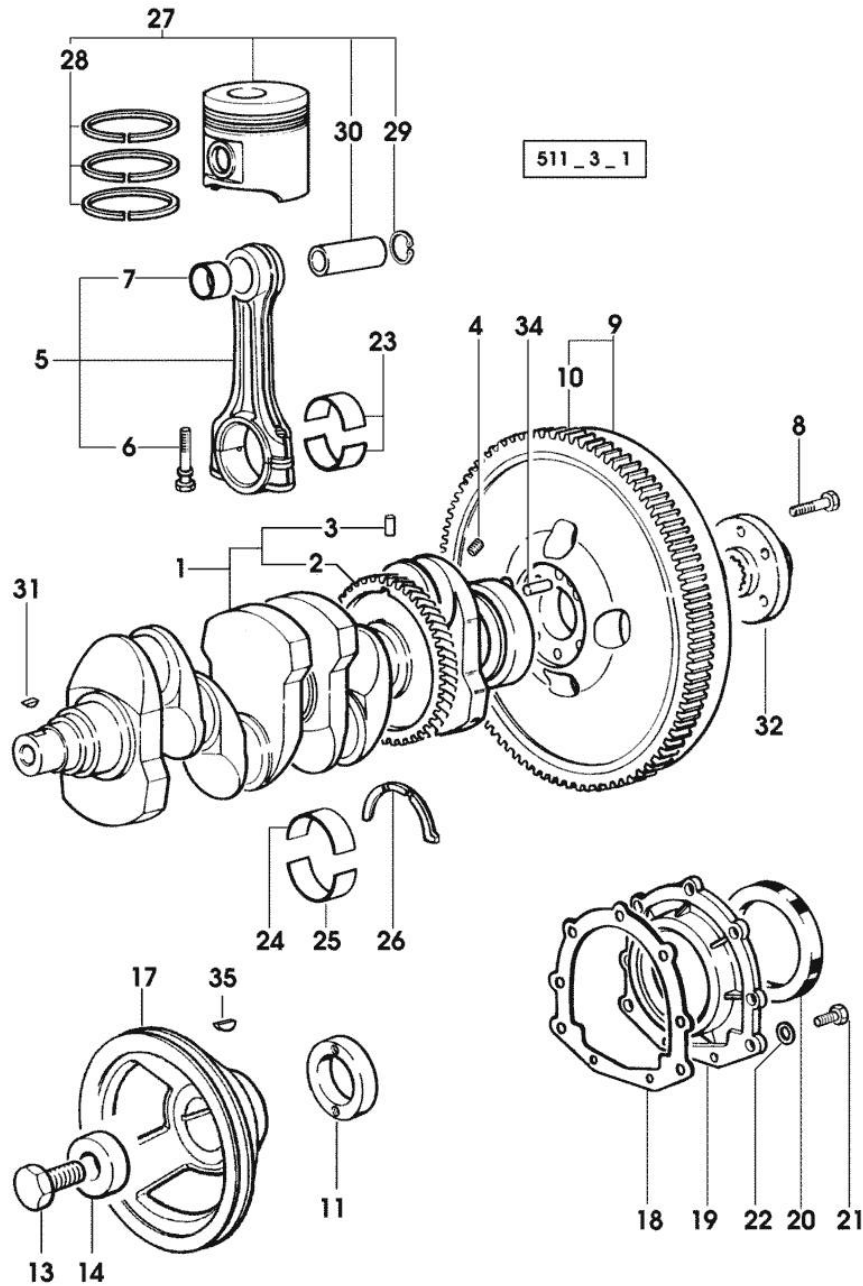

Section: ENGINE

ENGINE SHAFT - FRONT P.T.O. PULLEYS

Fig.	P/n	QTY	Name
------	-----	-----	------

Notes:

[674-70 N CROSS]

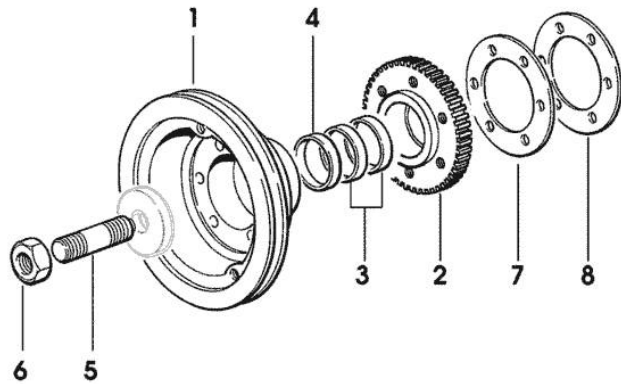

4 | 508 _ 4 | 1

1	0.082.1244.0/10	1	pulley - X 70HP
1	0.086.1244.0	1	pulley - X 60HP
2	0.011.3515.0/10	1	hub Z = 48
3	0.065.1256.0	2	ring 45x52
4	2.1579.865.0	1	spacer 45.2x51.8x10
5	2.0439.195.7	1	stud bolt m 20 p.1.5x80
6	2.1019.094.7	1	nut m 20 p.1.5
7	2.1589.137.0	3	shoulder ring 71x110x1
8	2.1589.136.0	1	shoulder ring 71x110x0.5

Buy Now



Our support email:

ebooklibonline@outlook.com