

100

CLAAS

15000200
TARGO C-SERIE

EG3010

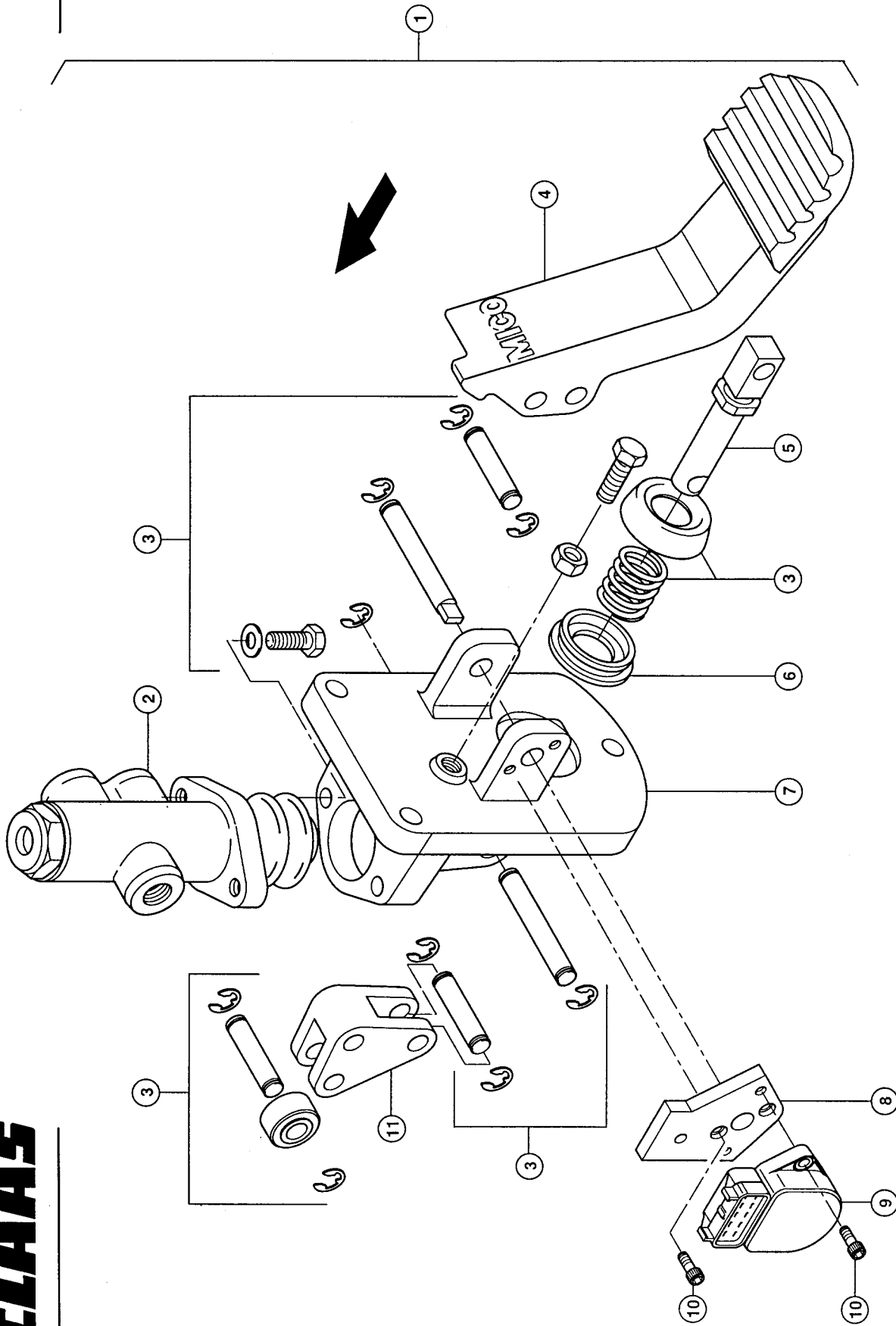

134570

BRAKE PEDAL CPL., SINGLE CIRCUIT

Pos.	Part No.	Description	Dimension	Quantity	Conditions
1	00 0318 230 0	BRAKE PEDAL		1	
2	00 0316 892 0	BRAKE VALVE		1	
2	00 0316 893 0	REPAIR KIT		1	
3	00 0325 436 0	REPAIR KIT		1	
4	00 0319 935 0	PEDAL		1	
5	00 0325 444 0	PLUNGER		1	
6	00 0325 441 0	SLEEVE		1	
7	00 0319 932 0	RECEPTION		1	
8	00 0319 934 0	SPACER		1	
9	00 0319 930 0	SENSOR		1	
10	00 0237 876 0	SOCKET HEAD SCREW	M5X12	4	
11	00 0325 437 0	SUPPORT		1	

101A

CLAAS

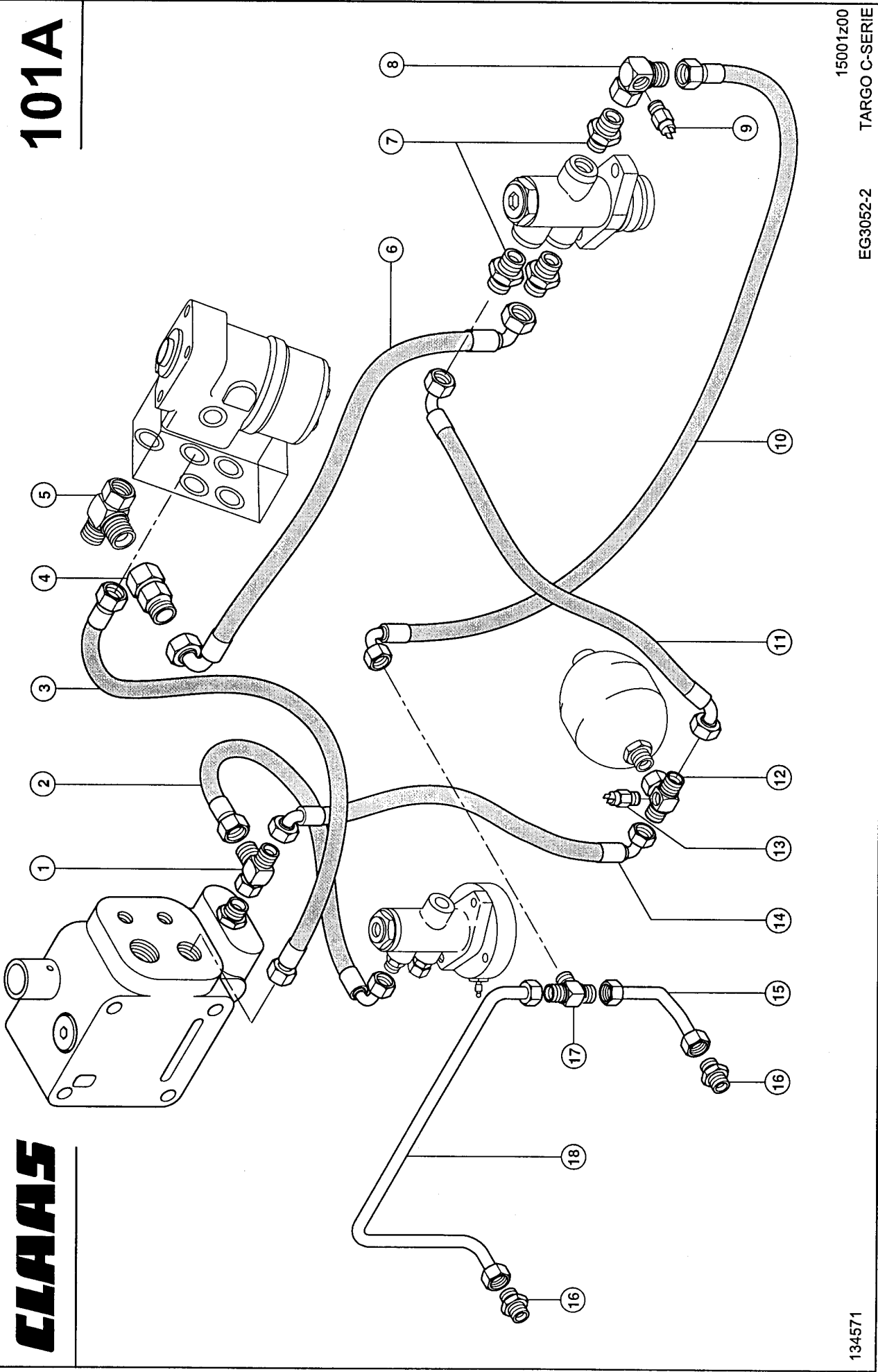

15001z00
TARGO C-SERIE
EG3052-2

134571

BRAKE PIPES AND HOSES

Pos.	Part No.	Description	Dimension	Quantity	Conditions
1	00 0249 866 0	L-UNION	W.ERS.D.2388900	1	1)
2	00 0325 880 1	HYDR. HOSE		1	
3	00 0349 363 1	HOSE PIPE	2SC 12 N45N 635	1	2)
3	00 0349 372 1	HYDR. HOSE	??? 12 N45N 710	1	3)
4	00 0238 719 0	REDUCING ADAPTER	RES-L15/10-OMS ERS.D.024	1	
5	00 0249 868 0	T-UNION, ADJUSTM.	SWORT-L15	1	
6	00 0310 016 1	HYDR. HOSE	1SN6	1	
7	00 0215 639 0	SCREW-IN FITTING	SDS-L10X9/16-18UNF -2A-TY	3	
8	00 0318 766 0	ELBOW UNION	SWOE-L10 MOD. 1/8NPTF	1	
9	00 0315 492 1	PRESSURE SWITCH	L=46/ SW 24	1	
10	00 0318 317 1	HYDR. HOSE	2SC 8 N90N 1040	1	2)
10	00 0349 369 1	HYDR. HOSE		1	3)
11	00 0349 484 0	HYDR. HOSE		1	
12	00 0317 678 0	T-PIECE	SWOBT-L10 MOD. 1/8NPTF	1	
13	00 0315 493 1	LOW PRESS.SWITCH		1	
14	00 0349 294 2	HYDR. HOSE	1SN6	1	
15	00 0318 326 0	PIPE	10X1X176-2	1	
16	00 0317 721 0	SCREW-IN FITTING	L10F-M10X1	2	
17	00 0238 795 0	TEE	T-L10	1	
18	00 0318 325 0	PIPE	10X1X551-3	1	

1)	Remarks	for trailer brake
2)	Remarks	with Targo C 40
3)	Remarks	with Targo C 50

102A

CLAAS

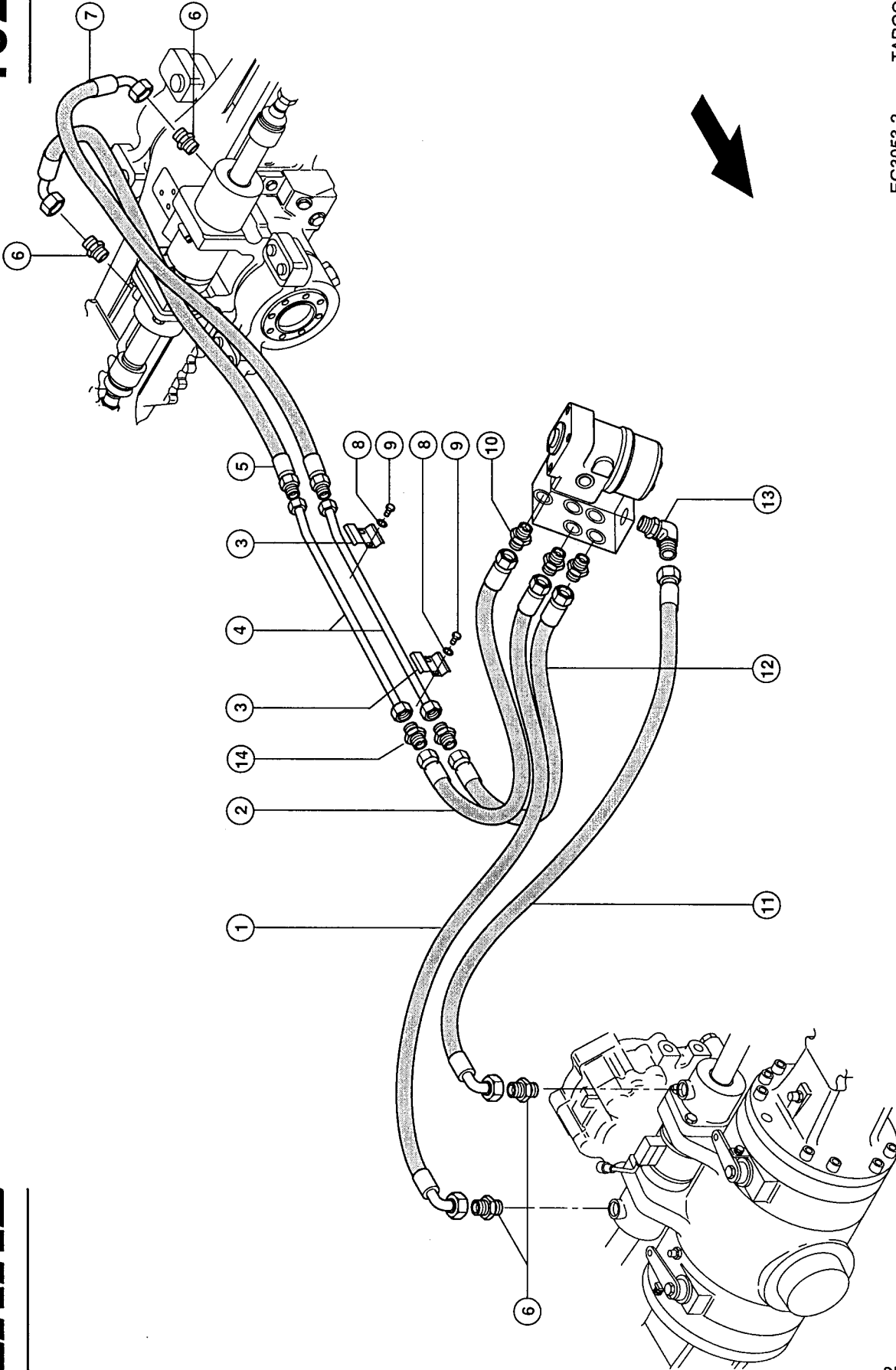

15002z00 TARGO C-SERIE EG3053-2

134572

STEERING HYDRAULICS

Pos.	Part No.	Description	Dimension	Quantity	Conditions
1	00 0349 366 1	HOSE PIPE		1	1)
1	00 0349 374 1	HYDR. HOSE		1	2)
2	00 0349 364 1	HYDR. HOSE	1SN10	2	1)
2	00 0349 371 1	HYDR. HOSE	2SN 10 N45N45 490 V90	2	2)
3	00 0315 509 0	PIPE CLAMP		2	
4	00 0318 623 0	PIPE	12X1,5X957-1	2	
5	00 0318 302 1	HYDR. HOSE	1SN10	1	
6	00 0216 170 0	SCREW-IN FITTING	SDS-L12XM18X1, 5-TYPE F	4	
7	00 0318 301 1	HYDR. HOSE	1SN10	1	
8	00 0239 386 0	CONTACT WASHER	A 6	2	
9	00 0237 877 0	HEXAGON HEAD BOLT	M6X10	2	
10	00 0316 193 0	SCREW-IN FITTING	SDS-L12X3/4-16UNF- 2A-TYP	3	
11	00 0325 786 1	HOSE		1	
12	00 0349 365 2	HYDR. HOSE		1	1)
12	00 0349 370 1	HYDR. HOSE	2SN 10 N45N45V90° 530	1	2)
13	00 0325 788 0	UNION	ERS.D.323	1	
14	00 0215 763 0	CONNECTOR	026.0/SDE-12X3 S-L12	2	
1)	Remarks	with Targo C 40			
2)	Remarks	with Targo C 50			

103

CLAAS

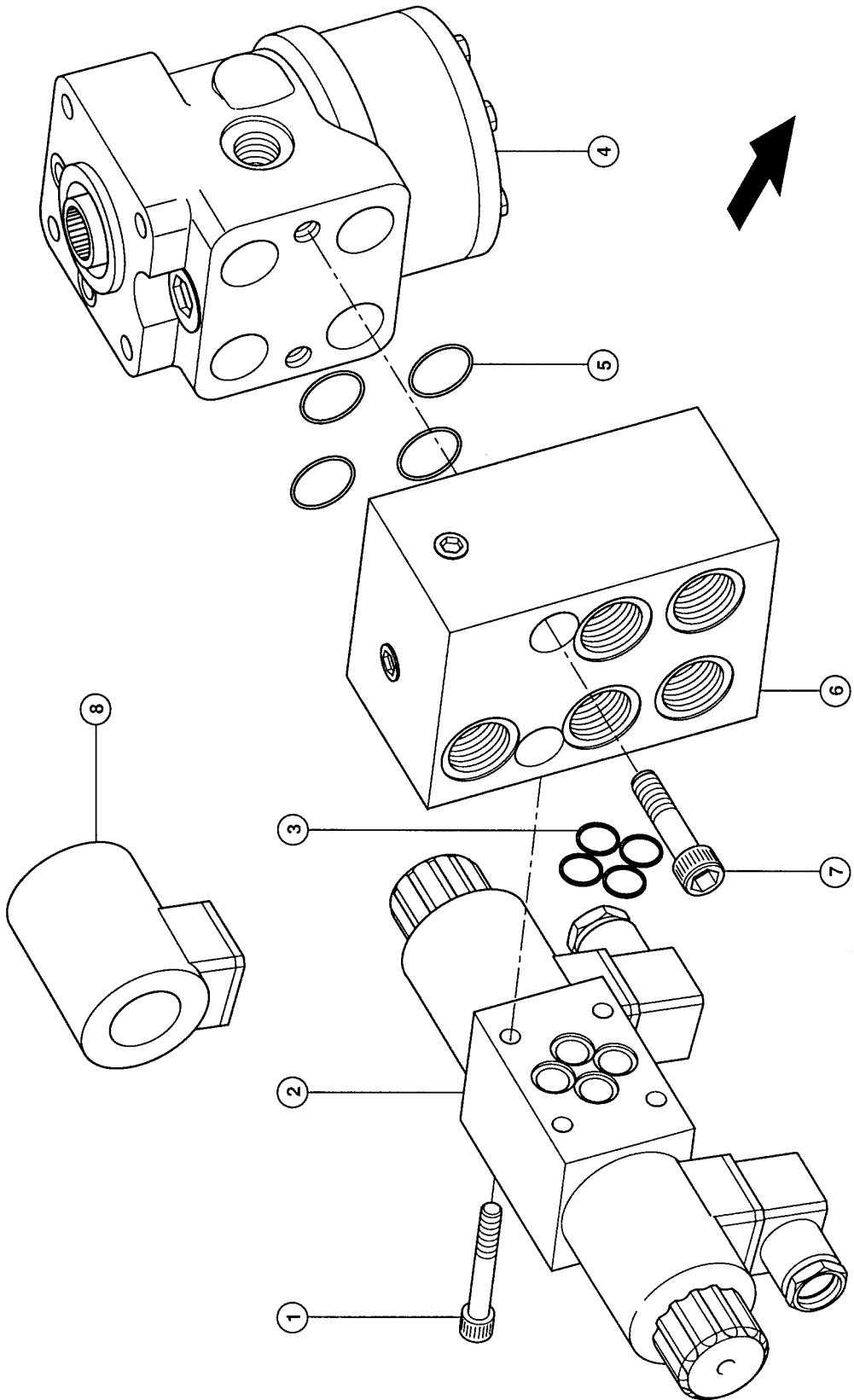

15003z00 TARGO C-SERIE EG3000-1

134573

STEERING HYDRAULICS

Pos.	Part No.	Description	Dimension	Quantity	Conditions
1	00 0242 208 0	SOCKET HEAD SCREW	M 5X 45 ERS.D. 242208.1	4	
2	00 0319 945 0	SOLENOID	DCV 03	1	
3	00 0319 949 0	SEAL KIT	4ST 9,25X1,68-N - FUER D	1	
4	00 0319 947 0	STEERING VALVE	OSPF 200 LS	1	
5	00 0079 899 0	O-RING	23,47X2,62-N	4	
6	00 0319 944 0	MANIFOLD		1	
7	00 0319 958 0	SCREW		2	
8	00 0349 665 0	ELECTRONIC MAGNET		2	

104A

CLAAS

15004z00
TARGO C-SERIE

B80259

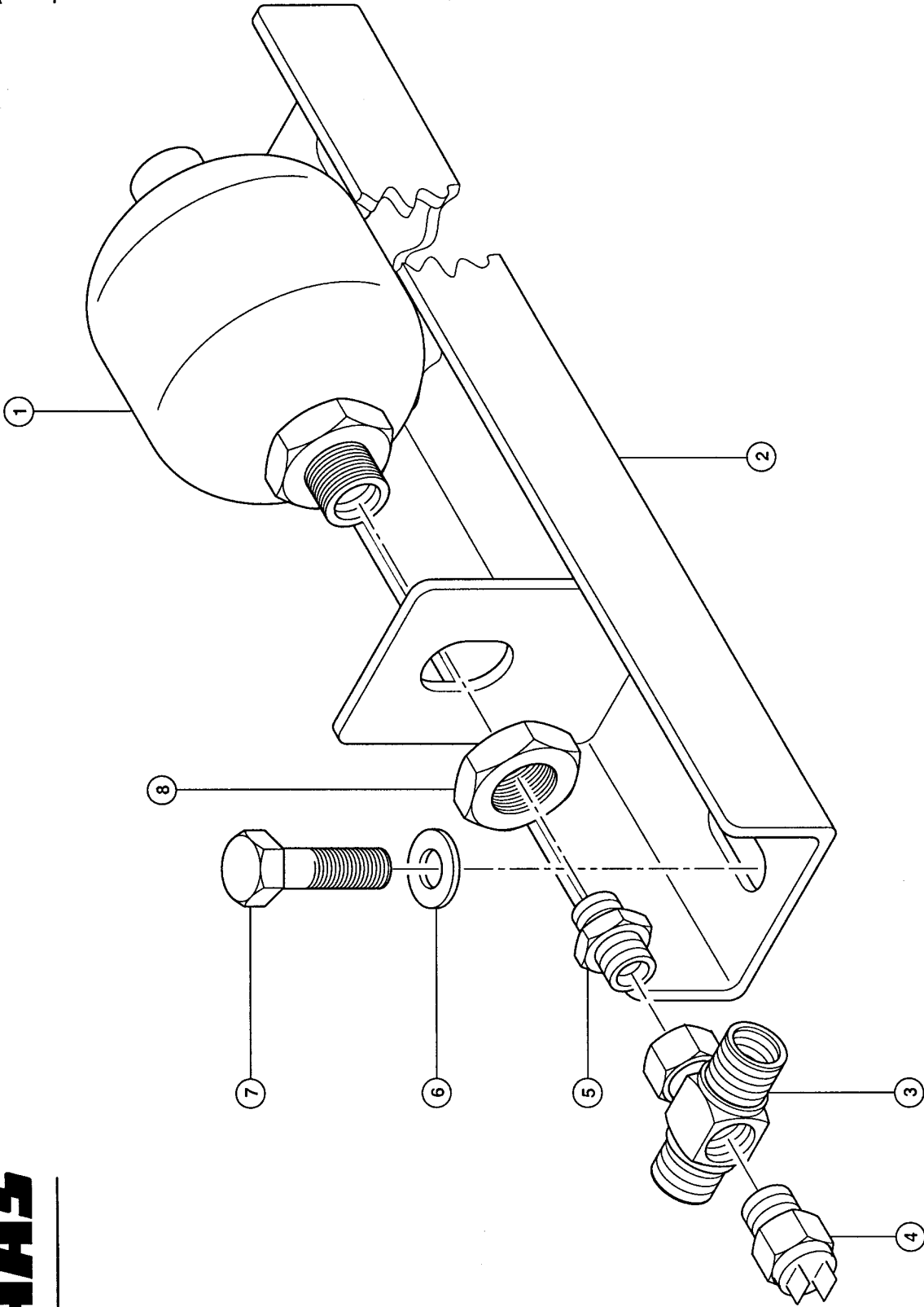

134574

BRAKE ACCUMULATOR

Pos.	Part No.	Description	Dimension	Quantity	Conditions
1	00 0323 884 0	ACCUMULATOR	0,75L 210BAR	1	
2	00 0349 513 1	BRACKET		1	
3	00 0317 678 0	T-PIECE	SWOBT-L10 MOD. 1/8NPTF	1	
4	00 0315 493 1	LOW PRESS.SWITCH		1	
5	00 0216 010 0	SCREW-IN FITTING	SDS-L10XG1/2A-TYPE E	1	
6	00 0239 388 0	CONTACT WASHER	A10-10,2X22,25X1,6	2	
7	00 0237 382 0	HEXAGON HEAD BOLT	M10X20	2	
8	00 0217 047 0	HEXAGONAL NUT	M33X1,5/10 HOCH/SW50	1	

200

15005z00
TARGO C-SERIE

EG3015-2

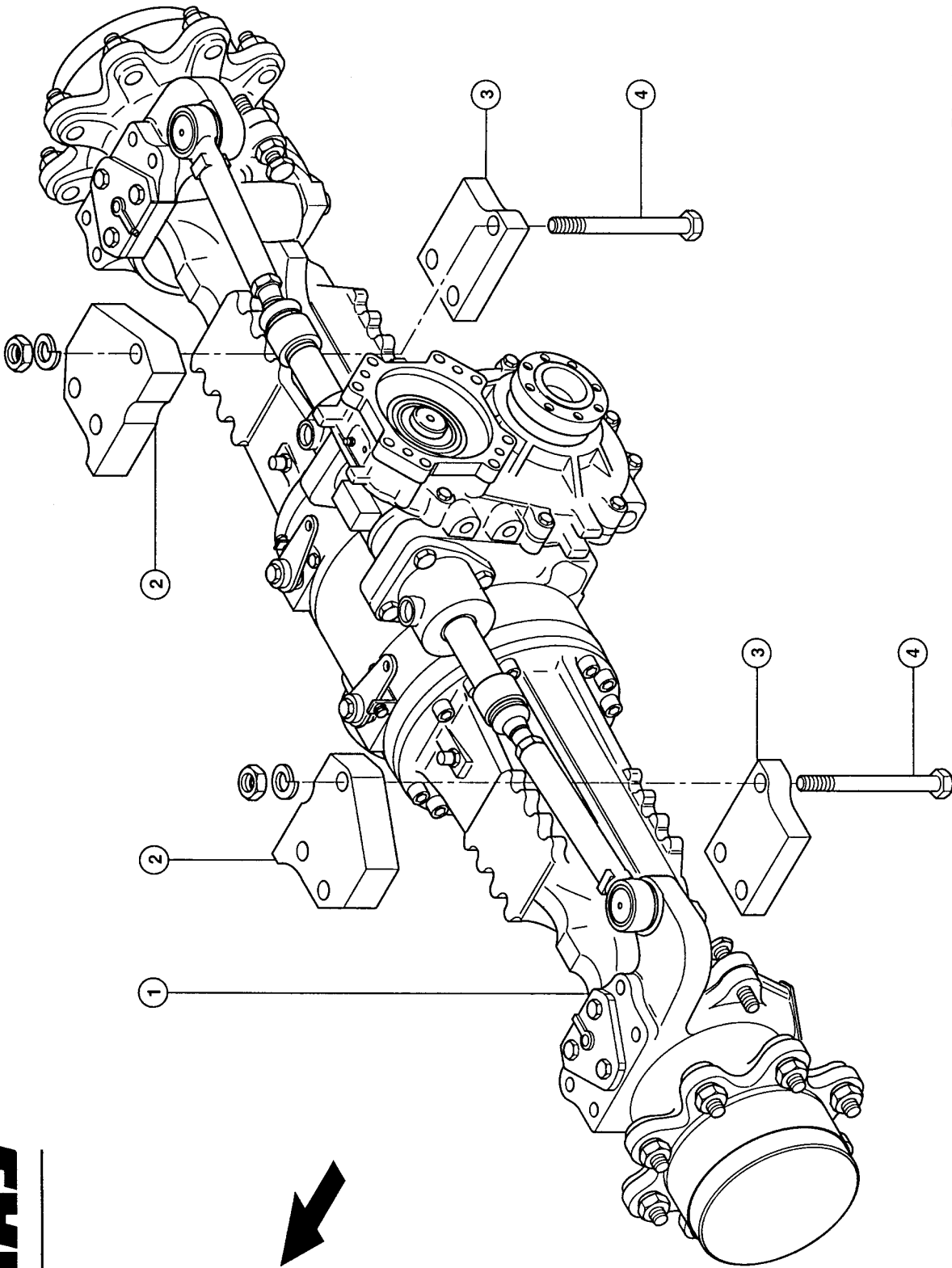

CLAAS

134575

FRONT AXLE

Pos.	Part No.	Description	Dimension	Quantity	Conditions
1	00 0318 380 0	FRONT AXLE	26.16 M	1	
2	00 0318 478 1	SPACING PIECE		1	1)
3	00 0318 388 1	AXLE PLATE		1	1)
4	00 0320 357 0	SCREW	M24X300	6	1)
4	00 0326 415 0	SCREW	M24X240	6	
4	00 0238 644 0	SPRING WASHER		6	
4	00 0238 643 0	HEXAGONAL NUT	M24	6	
1)	Remarks		with C 50		

201

CLAAS

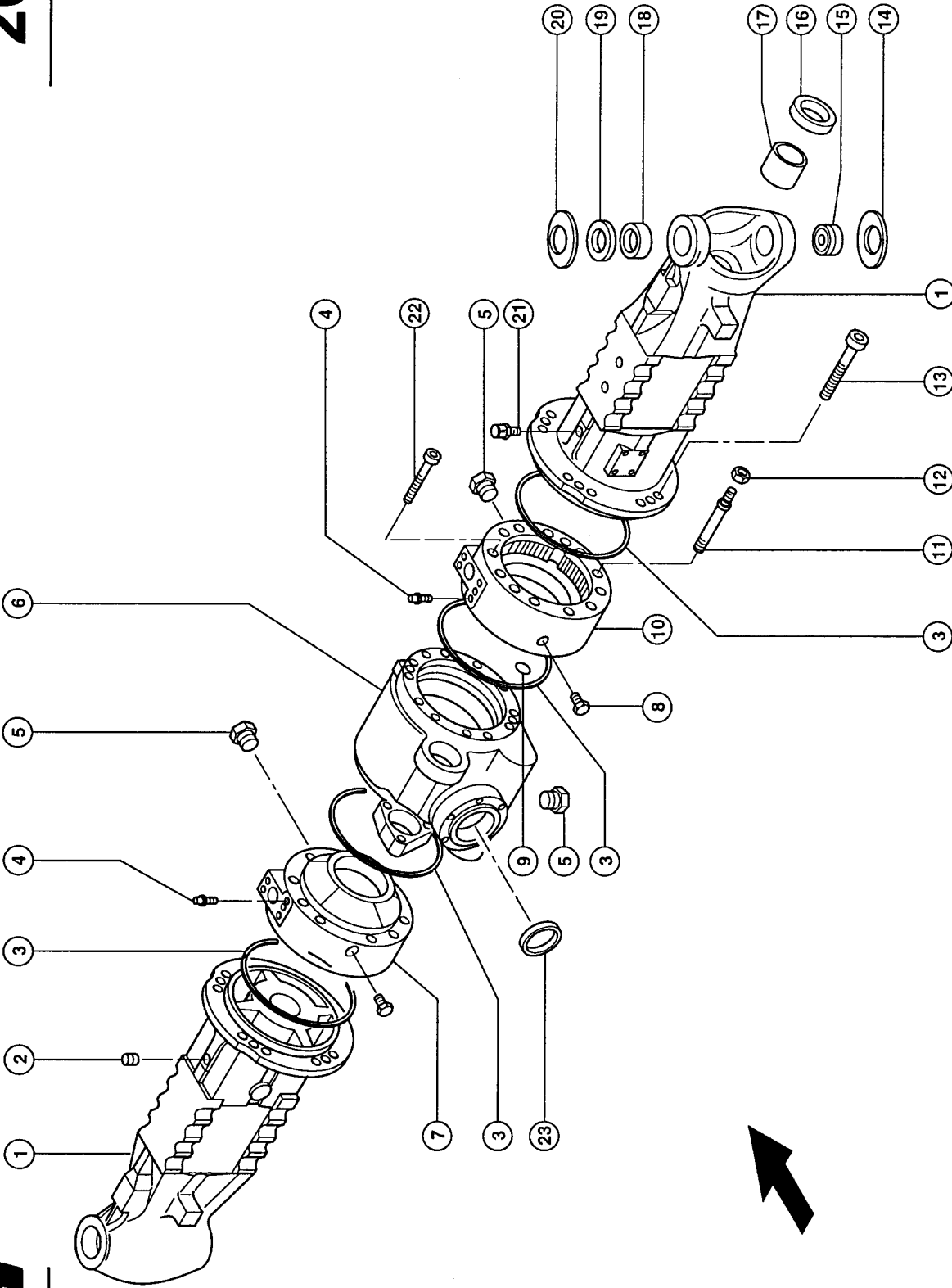

150006z00
MZ80061 TARGO C-SERIE

134576

Thank you so much for reading.
Please click the “Buy Now!”
button below to download the
complete manual.



After you pay.

You can download the most
perfect and complete manual in
the world immediately.

Our support email:

ebooklibonline@outlook.com