

Section: ENGINE

PARTS SET - ENGINE MOUNTING

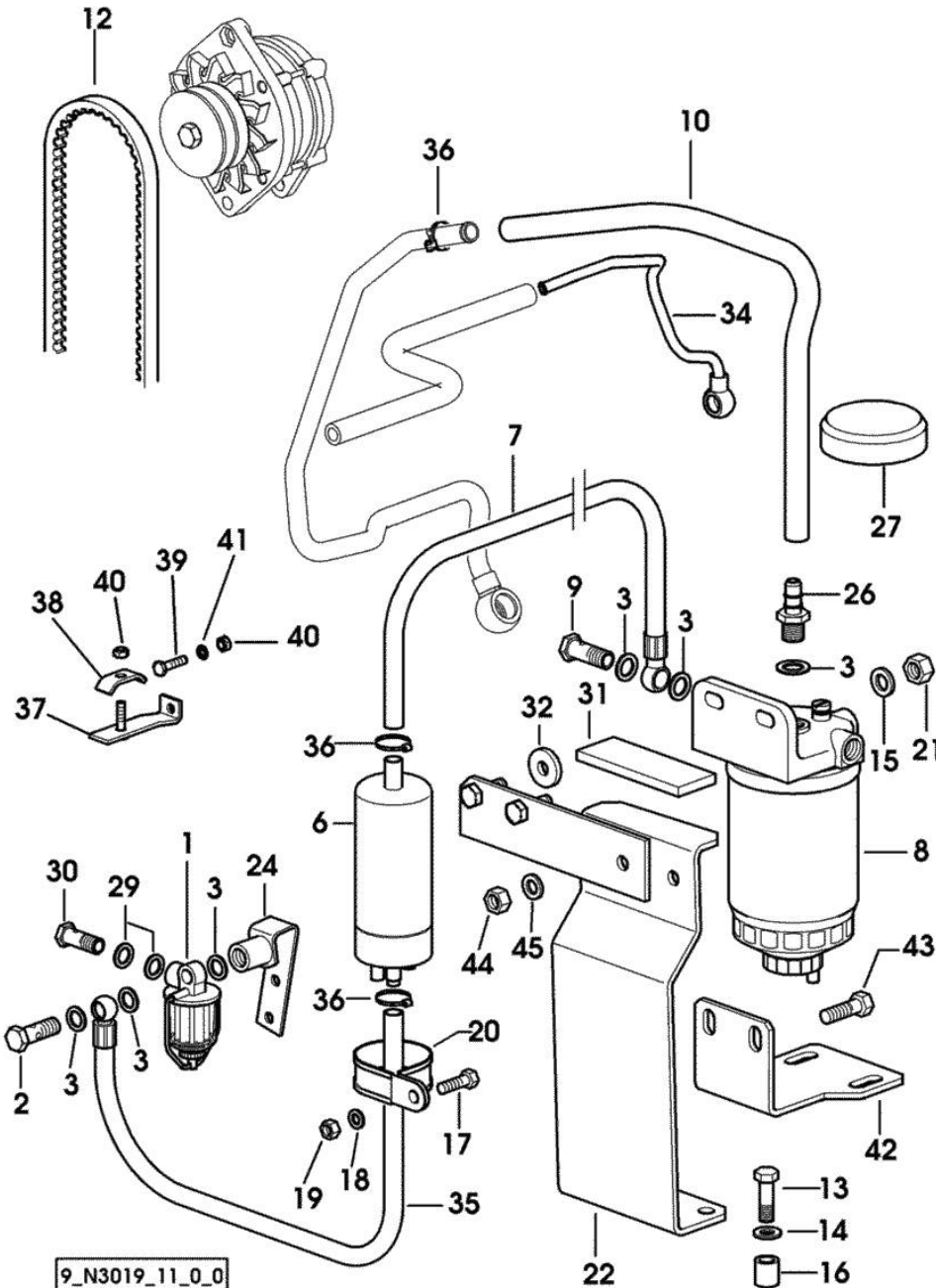

Fig.	P/n	QTY	Name
Notes:			
[Agrolux F 80]			
1	2.4319.220.0	1	precleaner COMPONENT PARTS SEE COMPONENTS LIST ☞ 2.4319.220.0
2	2.3339.040.2	1	pipe union m 14 p.1.5x45
3	2.1561.007.0	7	copper gasket 14,8x22.2
6	0.012.6508.3	1	pump
7	0.010.6209.3	1	tube
8	2.4319.230.0	1	fuel filter COMPONENT PARTS SEE COMPONENTS LIST ☞ 2.4319.230.0
9	2.3332.004.1	1	pipe union m 14 p.1.5
10	0.012.6449.0	1	tube
12	2.4119.163.0	1	belt mm 10.7x1500
13	2.0112.311.2	2	screw m 10 p.1.5 x 30
14	2.1310.006.2	2	flat washer 10.5x21
15	2.1470.006.2	2	lock washer 10
16	2.1579.149.2	2	spacer 11x18x19
17	2.0112.011.2	1	screw m 6 p.1x30
18	2.1310.002.2	1	flat washer 6.4x12.5
19	2.1011.103.2	1	nut m 6 p.1
20	2.6839.063.0	1	clamp Ø 50
21	2.1011.106.2	2	nut m 10 p.1.5
22	0.013.7962.3	1	bracket
24	0.011.8784.2	1	bracket
26	2.3339.723.2	1	pipe fitting m 14 p.1.5
27	0.010.6230.0/10	1	plug
29	2.1560.010.0	2	gasket 14.2 x 20
30	2.3332.004.2	1	pipe union m 14 p.1.5 x 27
31	0.257.8153.0	1	rubber 40 x 110 x 8
32	2.1599.599.2	2	washer 10.5x30x5
34	0.013.6696.3/10	1	tube
35	0.013.6704.3	1	tube
36	2.6851.001.0	5	clamp Ø 16/25
37	0.013.6697.3	1	bracket
38	0.154.6377.0	1	terminal
39	2.0114.013.2	1	screw m 6 p.1 x 35
40	2.1011.103.2	2	nut m 6 p.1
41	2.1470.002.2	1	lock washer 6
42	0.013.7800.0	1	bracket
43	2.0112.311.2	2	screw m 10 p.1.5 x 30
44	2.1011.106.2	2	nut m 10 p.1.5

9_N3019_11_0_0

PARTS SET - ENGINE MOUNTING

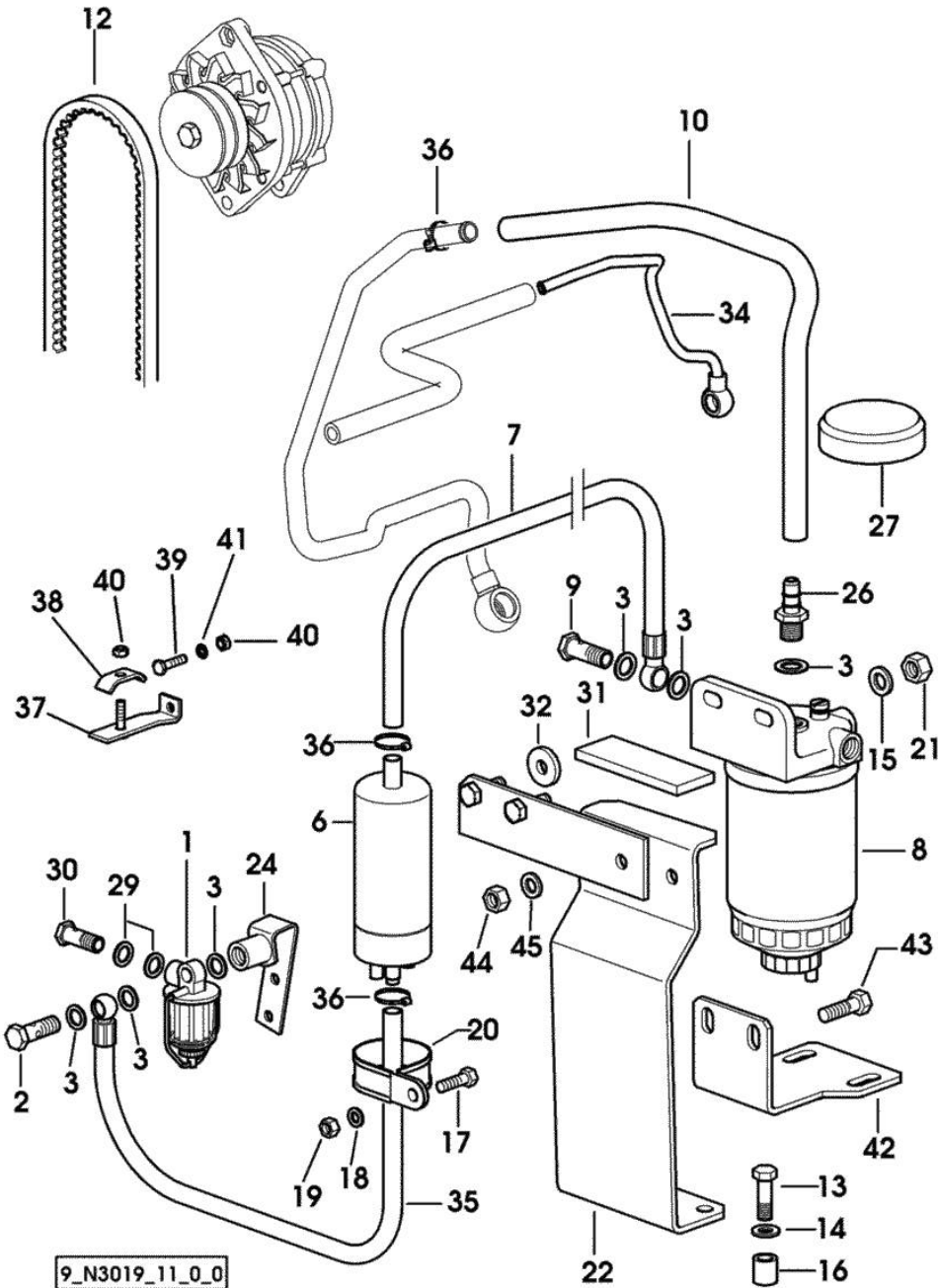

Fig.	P/n	QTY	Name
45	2.1310.006.2	4	flat washer 10.5x21

Section: ENGINE

FUEL PIPES

Fig.	P/n	QTY	Name
------	-----	-----	------

Notes:
[Agrolux F 80]

1	0.013.6694.3/30	1	tube
---	-----------------	---	------

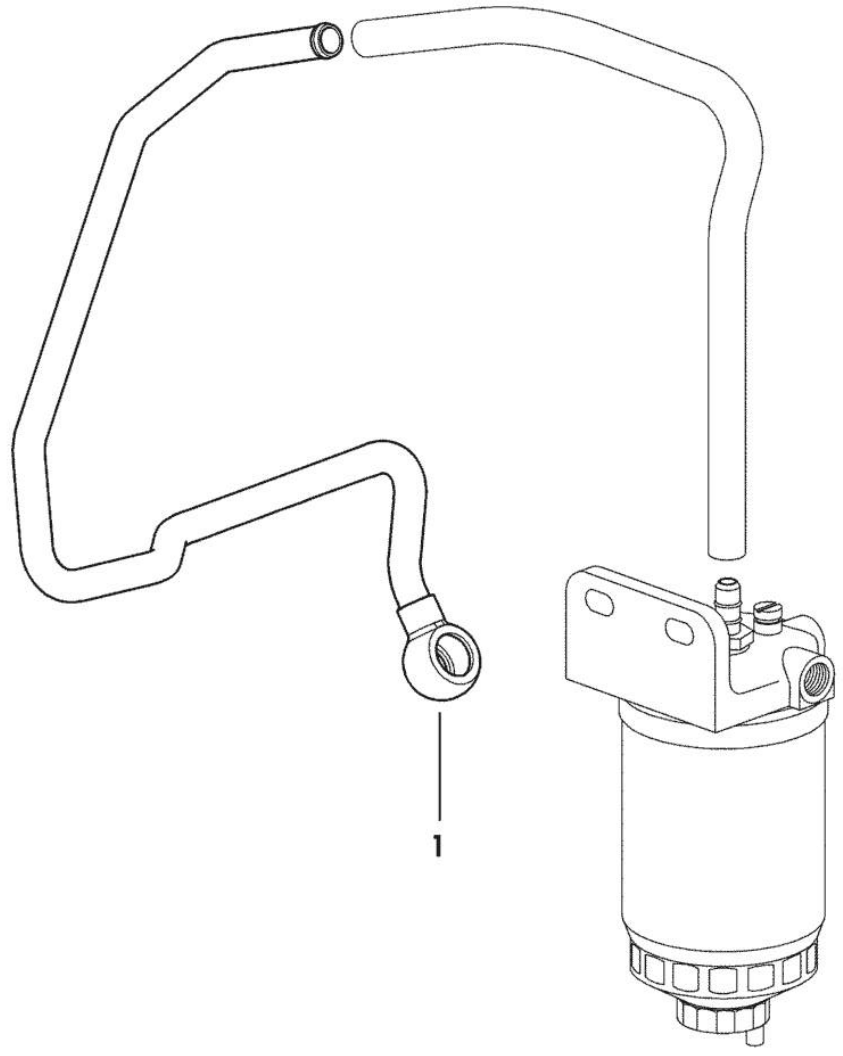

9_N3219_10_0_0

Section: ENGINE

EXHAUST SILENCER

Fig.	P/n	QTY	Name
------	-----	-----	------

Notes:

[Agrolux F 80]

1	0.008.3287.0/10	1	exhaust pipe
8	0.011.1316.0	1	clamp
9	0.008.3943.2/40	1	exhaust silencer
10	2.0119.234.3	1	screw m 10 p 1.5x80
11	2.1310.006.3	2	flat washer 10.5x21x2
12	0.431.5651.4	1	clamp
13	2.1011.106.3	1	nut m 10
17	0.467.5651.4	1	clamp
34	0.013.6922.3	1	bracket
35	0.013.7090.0	1	pin
36	0.013.7091.0/10	1	spacer
37	2.1310.006.2	2	flat washer 10.5x21
38	2.0422.609.2	1	stud bolt m 16 p.2x35
39	2.0422.411.2	1	stud bolt m 12 x 1,75 x 40
40	2.1310.010.2	1	flat washer 17x30
41	2.1310.007.2	1	flat washer 13 x 24
42	2.1011.109.2	1	nut m 16 p.2
43	2.1011.107.2	1	nut m 12 p.1.75

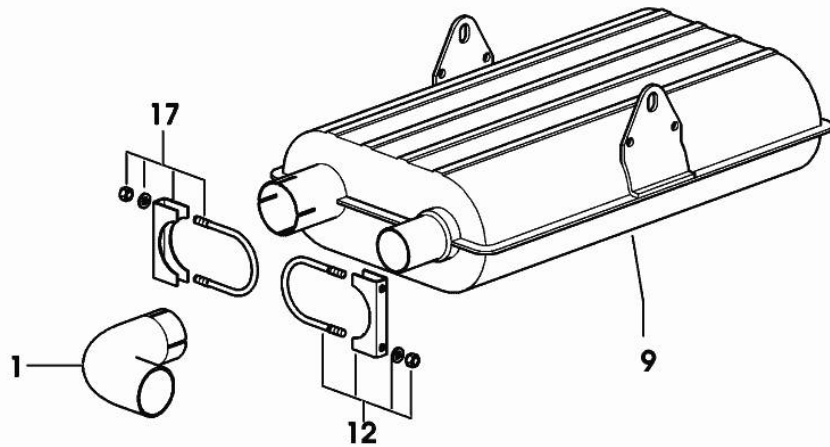
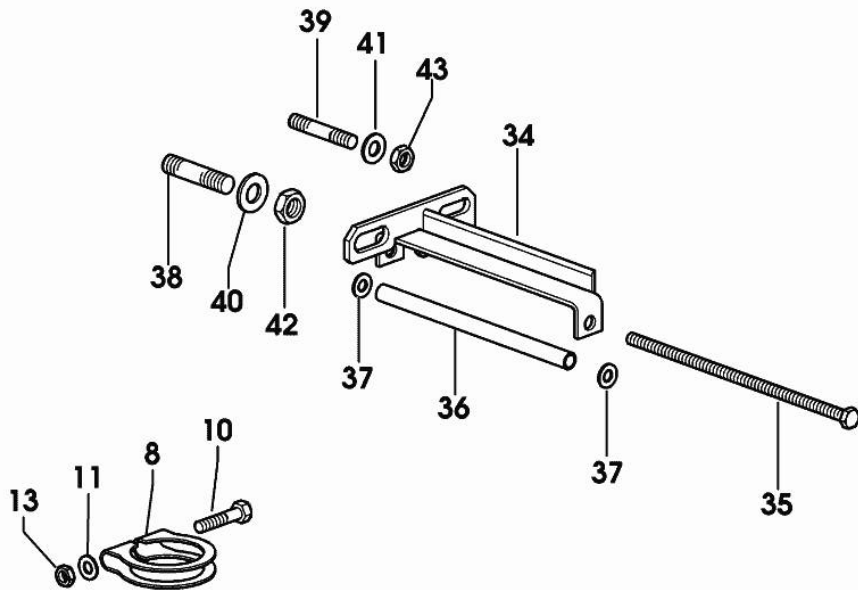

9_D4156_00_0_0

Section: ENGINE

EXHAUST PIPE

Fig.	P/n	QTY	Name
------	-----	-----	------

Notes:
[Agrolux F 80]

1	0.013.7195.0/10	1	tube
---	-----------------	---	------

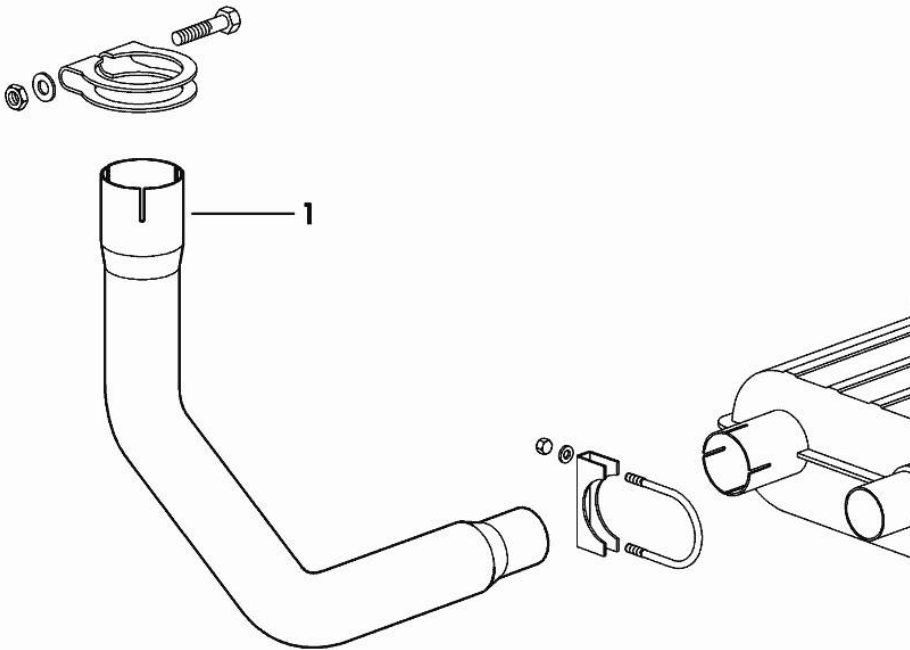

9_D0756_01_0_0

Section: ENGINE

METAL SILENCER GUARD

Fig.	P/n	QTY	Name
------	-----	-----	------

Notes:

[Agrolux F 80]

1	0.013.9151.3	1	shield
2	2.0112.304.2	1	screw m 10 p.1.5x14
3	2.1470.006.2	1	lock washer 10

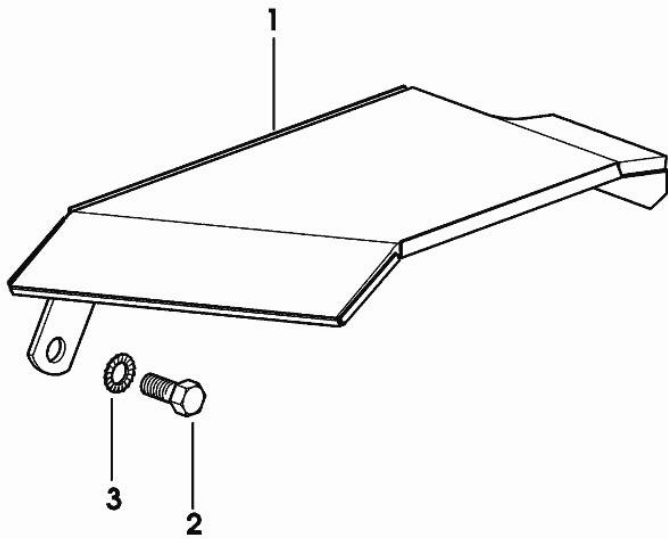

9_D0756_02_0_0

PRE-FILTER - COMPONENTS

Fig.	P/n	QTY	Name
1	2.4319.220.0	1	precleaner
2	0.000.0000.1		cannot be supplied
3	2.4319.220.6	1	fuel filter element

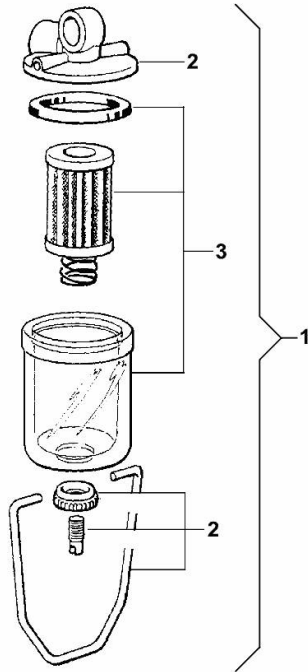

2_4319_220_0

Buy Now



Our support email:

ebooklibonline@outlook.com