

Section: ENGINE

**ENGINE BEARING**

Fig.	P/n	QTY	Name
------	-----	-----	------

Notes:

[GRIMPER 570-ST]

2	2.1532.072.0	1	oil seal 26.70x1.78
3	2.3199.405.2	1	plug m 28 p.1.5
5	2.0432.003.7	12	stud bolt m 8 p.1.25 / p.1 x 20
6	2.1559.188.2	4	bush 11.4 x 14 x16
7	2.1519.096.0/20	12	special oil seal 107.67x1.78 24857 <= X GRIMPER 570
7	2.1539.193.0	8	special oil seal 107.62x2.62 => 24858 X GRIMPER 570
8	2.1560.010.0	1	gasket 14.2 x 20
9	0.049.1152.0	1	cock 1152 <- X GRIMPER 570
9	2.3199.292.0	1	plug 1/4" gas -> 1153 X GRIMPER 570
10	0.082.1110.6/20	1	crankcase
10.1	2.3130.001.1	11	plug 1/8" gas
10.2	2.3130.002.1	2	plug 1/4" gas
10.3	2.3130.003.1	5	plug 3/8" gas
10.4	0.000.0000.1		cannot be supplied
10.4.1	0.065.1112.7	1	support
10.4.1.2	2.1699.165.0	1	bush 12.3x15x16
10.4.2	0.065.1114.0/10	3	support
10.4.3	0.065.1116.3	1	support
10.4.3.2	2.1699.165.0	1	bush 12.3x15x16
10.4.5	0.065.1140.0	4	special bushing 59X55X20
10.4.6	0.065.1141.0	1	special bushing 59X55X30
10.4.7	0.066.1151.0	1	pin
10.4.8	0.065.1117.0	10	screw m 12 x 100
10.8	2.3179.012.0	1	plug 60
10.9	2.1324.011.0	1	plug
11	0.066.1152.0/10	4	gasket
13	2.1549.154.2	4	bush 4.8x5.8x16
26	2.3120.101.0	1	plug m 18 p.1.5
28	2.1560.014.0	1	washer 18.2 x 24
30	2.3171.010.4	1	plug 25

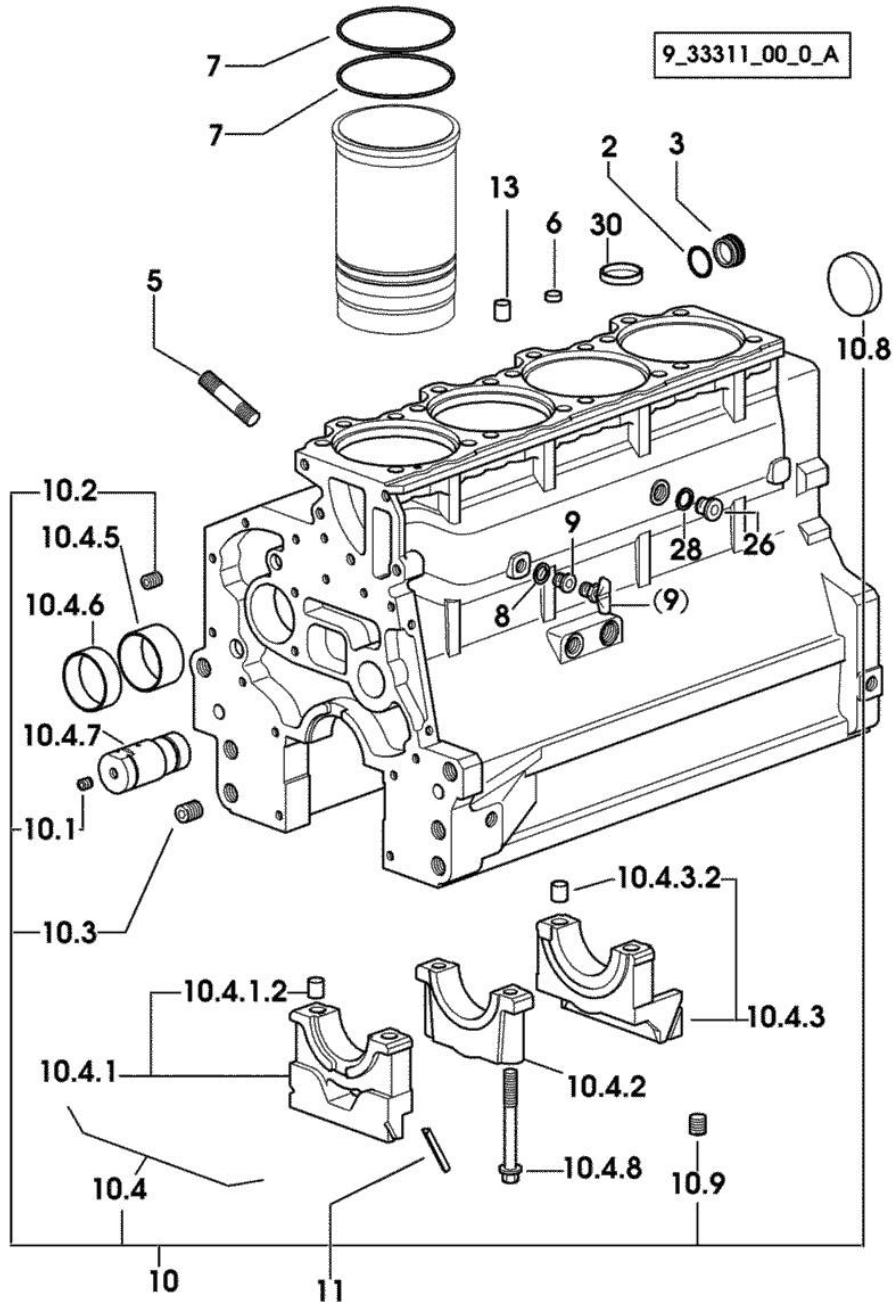

Section: ENGINE

**GUARD PLATE**

Fig.	P/n	QTY	Name
------	-----	-----	------

**Notes:**

[GRIMPER 570-ST]

1	0.007.1262.3/50	1	guard
2	0.007.1271.0/10	1	small column m 8 p.1.25 / L = mm 60
3	0.007.1272.0/10	2	small column m 8 p.1.25 / L = mm 50
5	2.1310.004.2	3	flat washer 8.4x17
7	2.0112.203.2	3	screw m 8 p.1.25 x 12

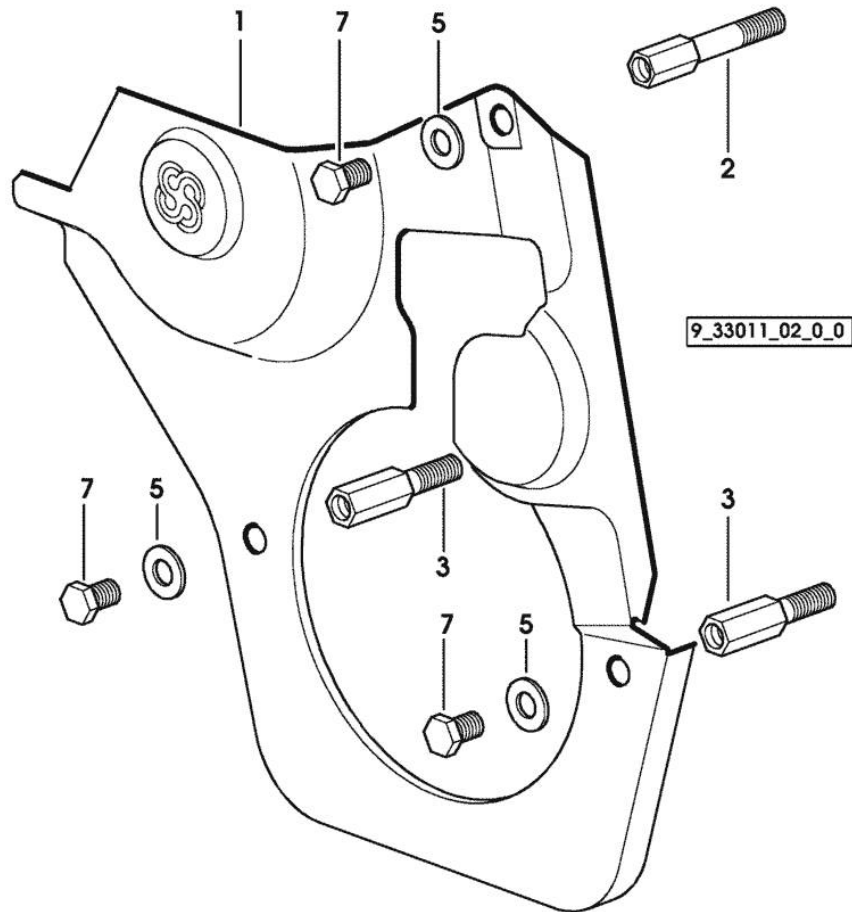

9\_33311\_00\_0\_B

Section: ENGINE

## TIMING CASE

Fig.	P/n	QTY	Name
------	-----	-----	------

## Notes:

[GRIMPER 570-ST]

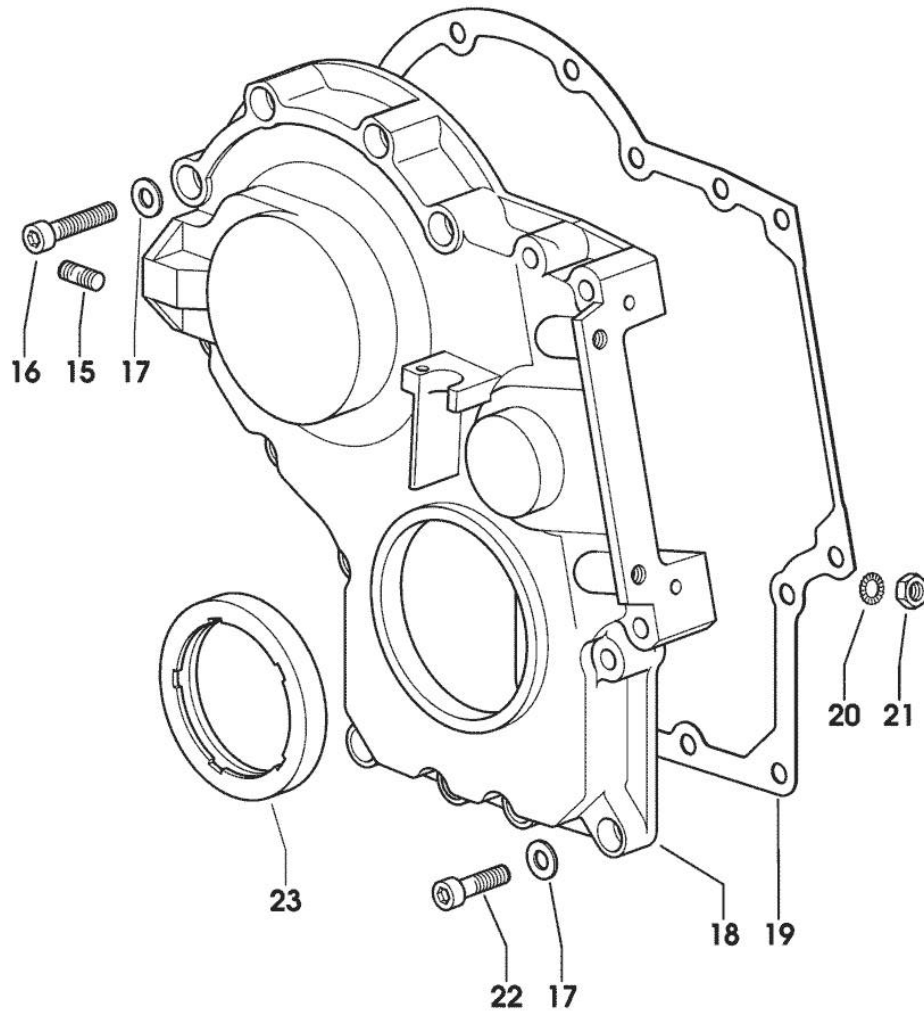

15	2.0432.003.7	2	stud bolt m 8 p.1.25 / p.1 x 20
16	2.0312.214.2	7	screw m 8 p.1.25 x 40
17	2.1480.014.1	15	washer 8
18	0.013.4981.0	1	guard -> 1271 X GRIMPER 570
18	0.065.1132.0/50	1	guard 1270 <- X GRIMPER 570
19	0.065.1150.0/30	1	gasket
20	2.1470.004.2	4	lock washer 8
21	2.1011.405.2	2	nut m 8 p.1
22	2.0312.208.2	8	screw m 8 p.1.25 x 25
23	2.1529.167.0	1	oil seal

Section: ENGINE

**CRANKCASE**

Fig.	P/n	QTY	Name
------	-----	-----	------

**Notes:**

[GRIMPER 570-ST]

6	2.0439.250.7	1	stud bolt m 12 / m 10 x 30
7	0.011.9294.0/10	1	bush
30	2.0112.511.2	8	screw m 14 p.2 x 30
31	2.1651.912.0	2	cylindrical plug 12x28
32	2.1651.917.0	1	cylindrical plug 12x40
33	2.0432.257.7	1	stud bolt m 12 p.1.75 - 1.25 x 30
34	0.007.9745.0/10	1	flange

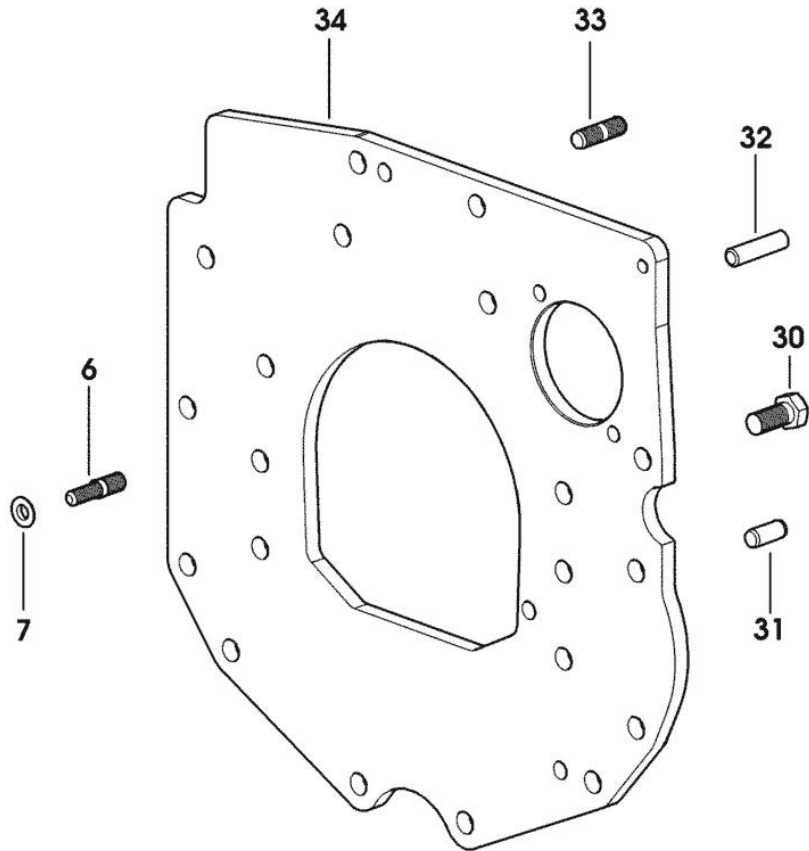

9\_33311\_02\_0\_0

Section: ENGINE

**SIDE PLUG FOR CYLINDER BLOCK**

Fig.	P/n	QTY	Name
------	-----	-----	------

**Notes:**

[GRIMPER 570-ST]

22	2.1560.017.0	1	gasket 22.2 x 27
23	2.3120.002.4	1	plug m 22 x 1.5

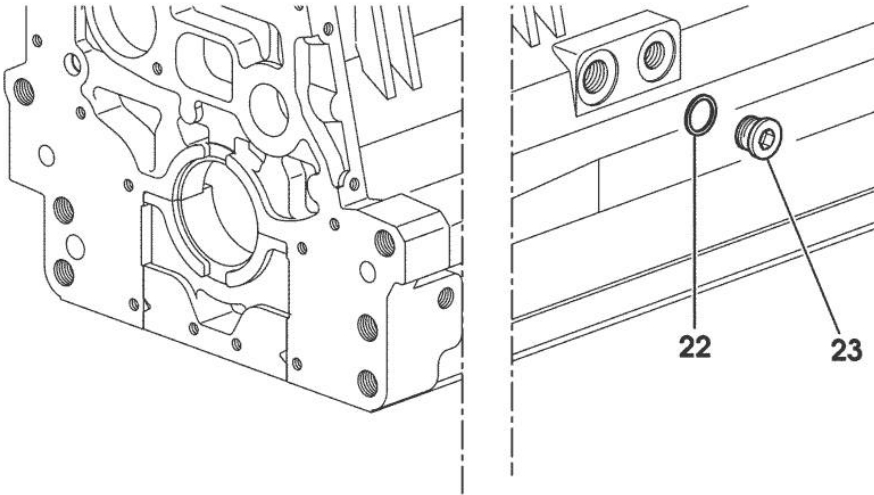

9\_33211\_07\_0\_0

Section: ENGINE

**PLUG**

Fig.	P/n	QTY	Name
------	-----	-----	------

**Notes:**

[GRIMPER 570-ST]

1	2.3130.003.1	2	plug 3/8" gas
---	--------------	---	---------------

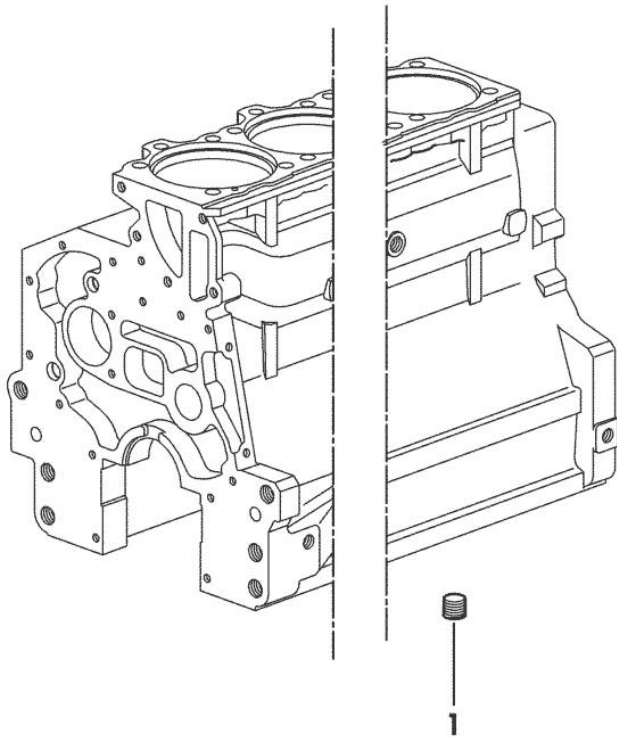

9\_33311\_06\_0\_0

Section: ENGINE

**CRANKSHAFT**

9\_33212\_00\_0\_0

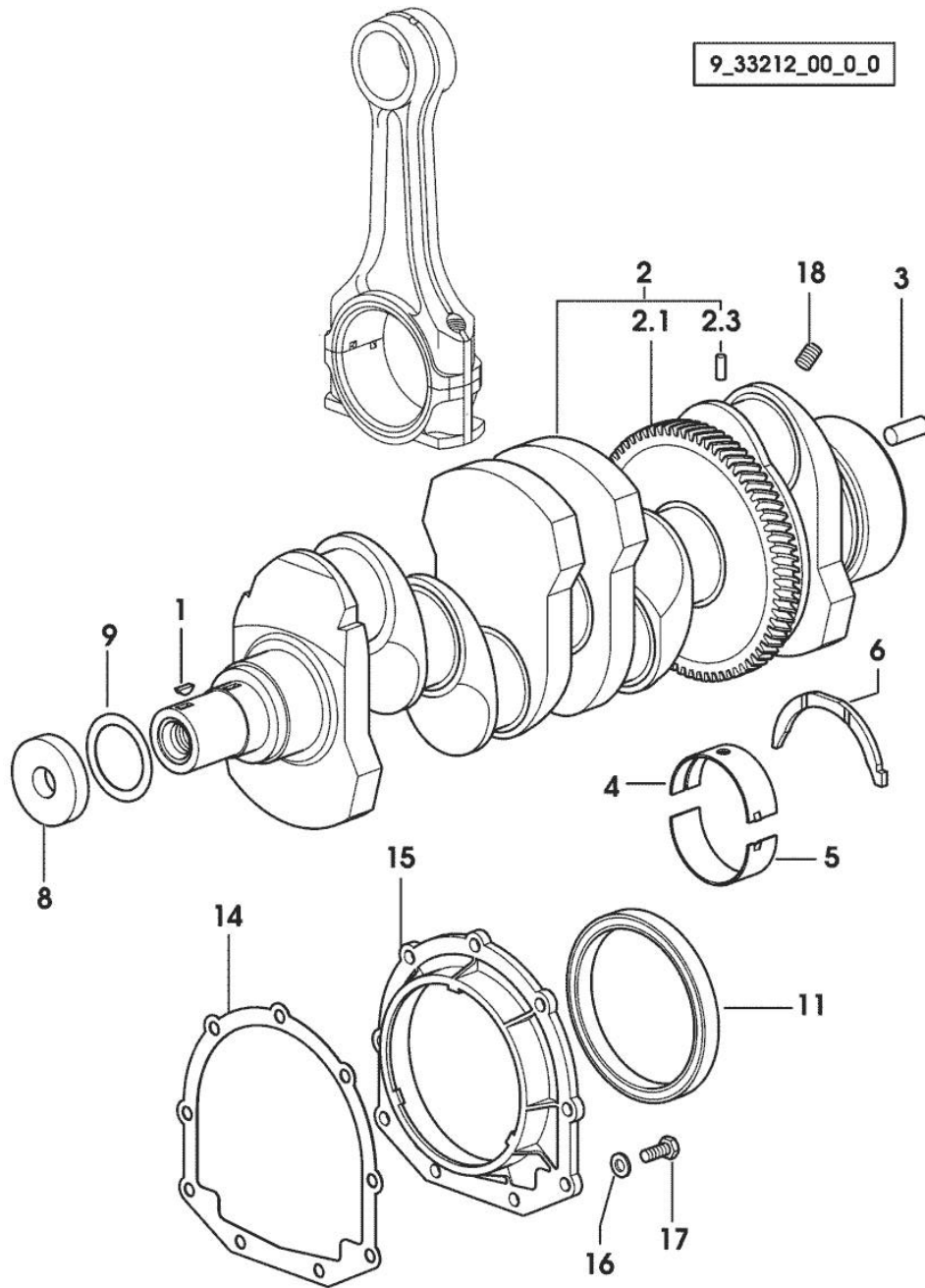

Fig.	P/n	QTY	Name
------	-----	-----	------

**Notes:**

[GRIMPER 570-ST]

1	2.1720.006.0	1	key 4x6.5
2	0.086.1210.3/30	1	crankshaft
2.1	0.065.1211.0/10	1	crown wheel
2.3	2.1630.608.0	1	pin 6x16
3	2.1651.915.0	1	pin 12x35
4	0.065.1215.0	5	main half bushing STANDARD
4	0.065.1215.7		main half bushing - mm 0.25
4	0.065.1215.8		main half bushing - mm 0.50
5	0.065.1216.0	5	main half bushing
5	0.065.1216.7		main half bushing - mm 0.25
5	0.065.1216.8		main half bushing - mm 0.50
6	0.065.1218.0	4	shim STANDARD
6	0.065.1218.7		shim + mm 0.10
6	0.065.1218.8		shim + mm 0.15
8	2.1599.524.7	1	washer 21x60x12
9	2.1589.189.0	2	shoulder ring mm 1.00
11	2.1529.073.0	1	special oil seal 110x130x13
14	0.065.1254.0/20	1	gasket
15	0.007.1711.0/10	1	cover
16	2.1475.002.2	9	conical washer 8
17	2.0112.207.2	9	screw m 8 p 1.25 x 20
18	2.3130.001.1	4	plug 1/8" gas

**Buy Now**



Our support email:

[ebooklibonline@outlook.com](mailto:ebooklibonline@outlook.com)