

**GEARBOX - REAR**

Fig.	P/n	QTY	Name
------	-----	-----	------

**Notes:**

[R3 85 TB ->5001]

1	0.014.9666.0/40	1	gear box
2	2.1651.811.0	1	cylindrical plug 10x24
3	2.1651.911.0	1	cylindrical plug
4	2.1470.006.2	28	lock washer 10
5	2.0112.307.2	18	screw m 10 p.1.5 x 20
7	0.255.3134.0/10	1	small cover
8	2.1481.007.1	4	washer 8
9	2.0112.207.2	4	screw m 8 p 1.25 x 20
11	2.3199.250.0	1	plug m 30 p.1
12	2.3171.006.4	1	plug Ø 16
13	2.1011.421.2	10	nut m 10 p.1.25
14	2.1560.020.0	2	copper gasket 24.3x32
15	2.3199.083.2	2	plug m 24 p.1.5
16	2.1560.026.0	1	gasket 35.3x41
17	2.3199.002.2	1	plug 1 gas
19	0.014.9265.2	1	division
22	2.1560.014.0	1	washer 18.2 x 24

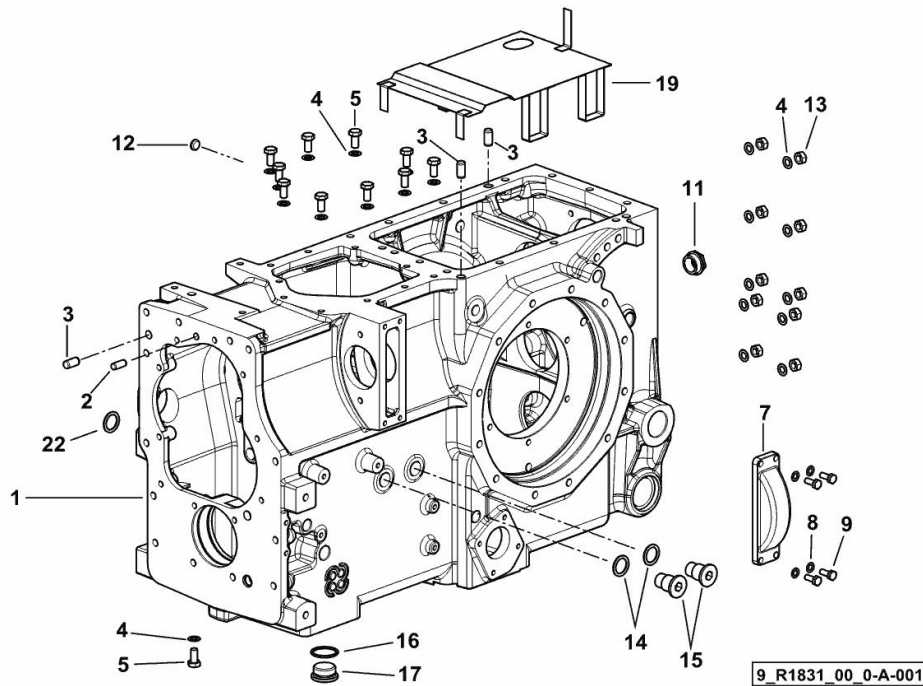

Section: D0 - TRANSMISSION  
**GEARBOX UPPER COVER**

Fig.	P/n	QTY	Name
------	-----	-----	------

Notes:  
[R3 85 TB ->5001]

1	0.016.0020.3/10	1	cover
---	-----------------	---	-------

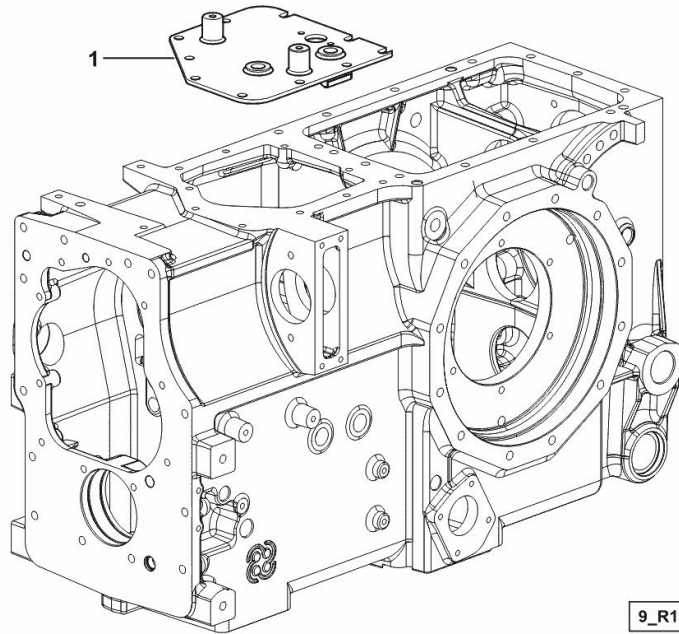

Section: D0 - TRANSMISSION  
**GEARBOX LOWER COVER**

Fig.	P/n	QTY	Name
------	-----	-----	------

Notes:  
[R3 85 TB ->5001]

21	0.255.3128.0/20	1	cover
----	-----------------	---	-------

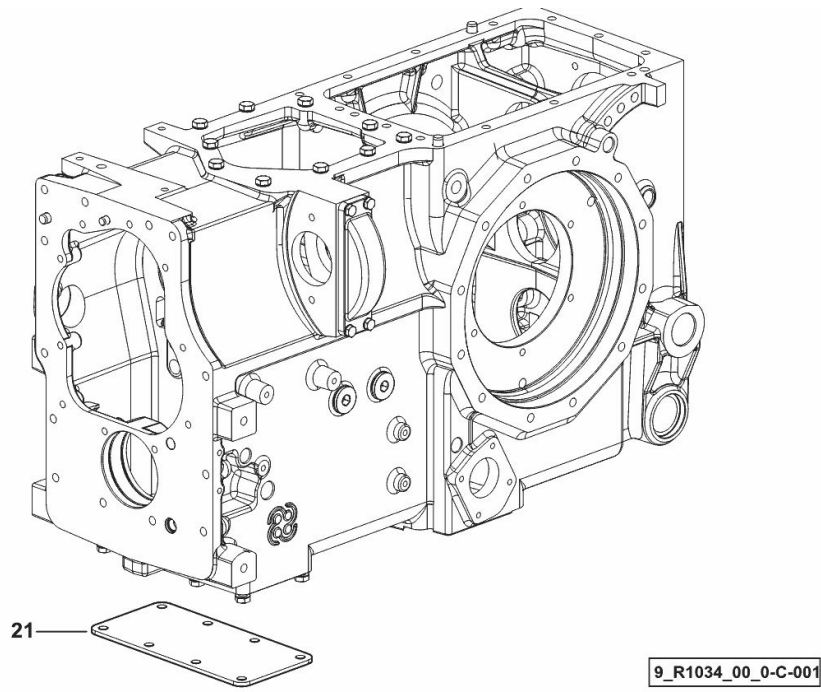

**COVER FOR TYPES WITHOUT SYNCHRO PTO**

Fig.	P/n	QTY	Name
------	-----	-----	------

**Notes:**

[R3 85 TB -&gt;5001]

1	0.255.3131.0/10	1	flange
2	2.3171.007.4	1	plug Ø 18
3	2.0432.155.7	4	stud bolt m 10 p.1.5 / p. 1.25 x 25

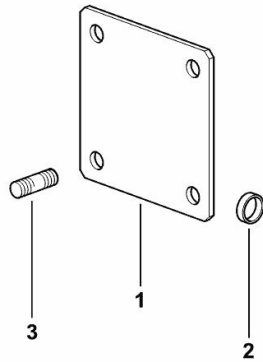

9\_40536\_01\_0-A-001

**5-SPEED GEARBOX INTERNAL FLANGES**

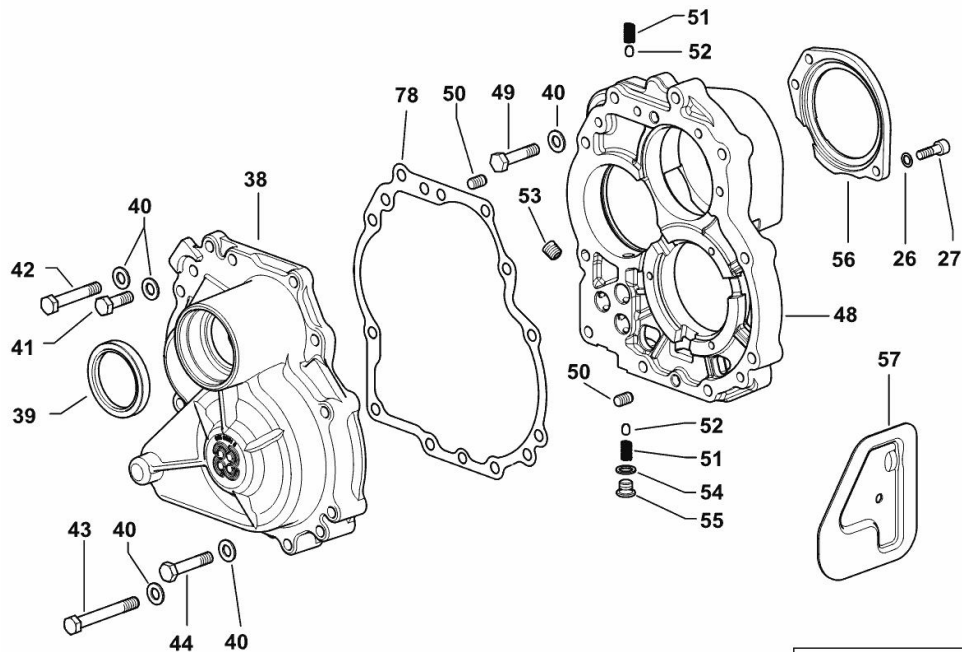

9\_H1433\_01\_0-A-001

Fig.	P/n	QTY	Name
------	-----	-----	------

Notes:

[R3 85 TB ->5001]

26	2.1480.014.2	6	washer 8
27	2.0312.208.2	6	screw m 8 p.1.25 x 25
38	0.015.0581.0	1	cover
39	2.1520.329.0	1	oil seal 55x72x10
40	2.1475.003.2	15	washer 10
41	2.0112.311.2	4	screw m 10 p.1.5 x 30
42	2.0112.321.2	5	screw m 10 p.1.5 x 60
43	2.0112.325.2	3	screw m 10 p.1.5 x 80
44	2.0112.319.2	1	screw m 10 p.1.5 x 50
48	0.014.8438.0/30	1	flange ( -> 5001 )
49	2.0112.317.2	2	screw m 10 p.1.5 x 45
50	2.1651.807.0	2	pin 10 x 16
51	2.4019.622.1	3	spring 6.3 x 9.5 x 1.6 x 22.4
52	2.2999.156.0	4	ball Ø 10
53	2.3131.001.4	1	plug m 12 p.1.5
54	2.1560.008.0	2	gasket 12.2 x 18
55	2.3199.164.2/20	2	plug m 12 p.1.5
56	0.014.8340.0/10	1	cover
57	0.007.3562.3/10	1	cover
78	0.015.6286.0	1	gasket

**5-SPEED GEARBOX INTERNAL FLANGES**

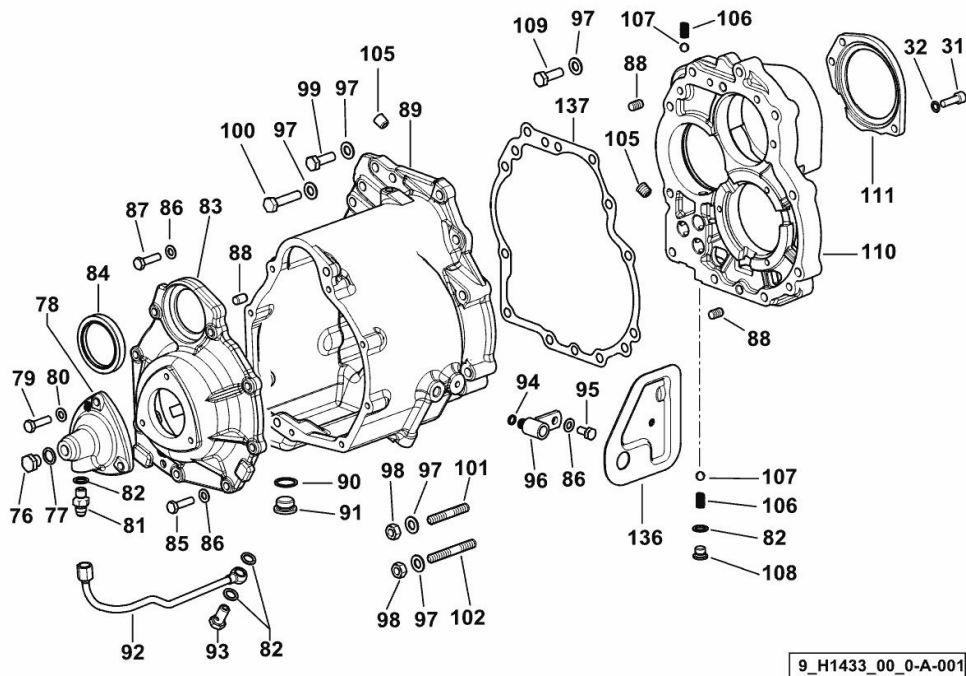

9\_H1433\_00\_0-A-001

Fig.	P/n	QTY	Name
------	-----	-----	------

**Notes:**

- FOR TYPES WITH HI - LO [R3 85 TB ->5001]

31	2.0312.208.2	6	screw m 8 p.1.25 x 25
32	2.1480.014.2	6	washer 8
76	2.3110.403.1	1	plug m 14 p.1.5x12
77	2.1560.010.0	1	gasket 14.2 x 20
78	0.007.3417.0/20	1	manifold
79	2.0112.209.2	3	screw m 8 p 1.25 x 25
80	2.1470.004.2	5	lock washer 8
81	2.3339.453.2	1	pipe fitting m 12 p.1.25-1/2"
82	2.1560.008.0	5	gasket 12.2 x 18
83	0.014.9205.0	1	cover
84	2.1520.329.0	1	oil seal 55x72x10
85	2.0112.211.2	6	screw m 8 p.1.25 x 30
86	2.1475.002.2	9	conical washer 8
87	2.0112.213.2	4	screw m 8 p.1.25 x 35
88	2.1651.807.0	4	pin 10 x 16
89	0.014.9206.0/40	1	box
90	2.1560.017.0	1	gasket 22.2 x 27
91	2.3199.001.2	1	plug 1/2" gas
92	0.007.3544.3	1	tube
93	2.3332.003.1	1	pipe union m 12 p.1.25
94	2.1530.014.0	1	oil seal
95	2.0112.205.2	1	screw m 8 p.1.25 x 16
96	0.007.3566.2	1	pipe union m 14 p.1.5
97	2.1475.003.2	15	washer 10
98	2.1011.421.2	5	nut m 10 p.1.25
99	2.0112.311.2	4	screw m 10 p.1.5 x 30
100	2.0112.321.2	4	screw m 10 p.1.5 x 60
101	2.0432.165.7	1	stud bolt m 10 p.1.5-1.25x50
102	2.0432.171.7	4	stud bolt m 10 p.1.5-1.25x80
105	2.3131.001.4	1	plug m 12 p.1.5
106	2.4019.622.1	3	spring 6.3 x 9.5 x 1.6 x 22.4
107	2.2999.156.0	4	ball Ø 10
108	2.3199.164.2/20	2	plug m 12 p.1.5
109	2.0112.317.2	2	screw m 10 p.1.5 x 45
110	0.014.8438.0/30	1	flange (-> 5006)
111	0.014.8340.0/10	1	cover
136	0.007.3563.3/10	1	cover
137	0.015.6286.0	1	gasket

**5-SPEED GEARBOX INTERNAL CONTROLS**

Fig.	P/n	QTY	Name
------	-----	-----	------

**Notes:**

[R3 85 TB ->5001] 5004 <-

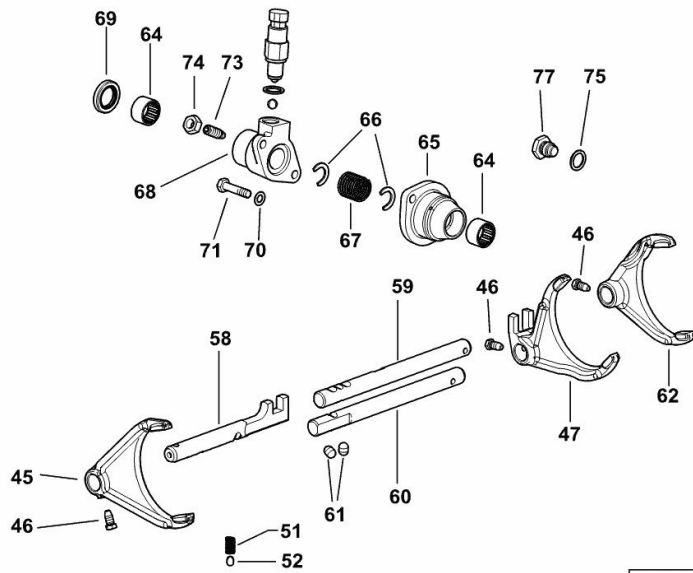

9\_H1433\_01\_0-E-002

45	0.013.0009.0/10	1	fork
46	2.0399.019.1	3	screw m 8 p.1 x 16
47	0.012.4169.0/20	1	fork
51	2.4019.622.1	3	spring 6.3 x 9.5 x 1.6 x 22.4
52	2.2999.156.0	4	ball Ø 10
58	0.255.6478.0/40	1	rod
59	0.255.6421.0/20	1	rod
60	0.255.6477.0/20	1	rod
61	2.1699.159.0	2	cap 10 x 14.1
62	0.013.0010.0/10	1	fork
64	2.2725.030.0	2	roller cage 22 x 28 x 16
65	0.011.7127.0/20	1	support
66	0.008.5405.0	2	ring
67	2.4019.698.1/10	1	spring 21 x 25 x 46
68	0.014.9383.0/20	1	support
69	2.1519.075.0	1	oil seal 22 x 35 x 6
70	2.1470.004.2	2	lock washer 8
71	2.0112.213.2	2	screw m 8 p.1.25 x 35
73	2.0399.050.2	1	screw m 10 p.1 x 30
74	2.1011.406.2	1	nut m 10 p.1
75	2.1560.012.0	2	gasket 16.2 x 22
77	2.3199.263.2	1	plug m 16 p.2x16x22

**Buy Now**



Our support email:

[ebooklibonline@outlook.com](mailto:ebooklibonline@outlook.com)