

CRANKCASE

Fig.	P/n	QTY	Name
------	-----	-----	------

Notes:

[Rekord 80.4 2WD ->L10S704WXE45001] [Rekord 80.4 4WD ->L10S704WTE45001]

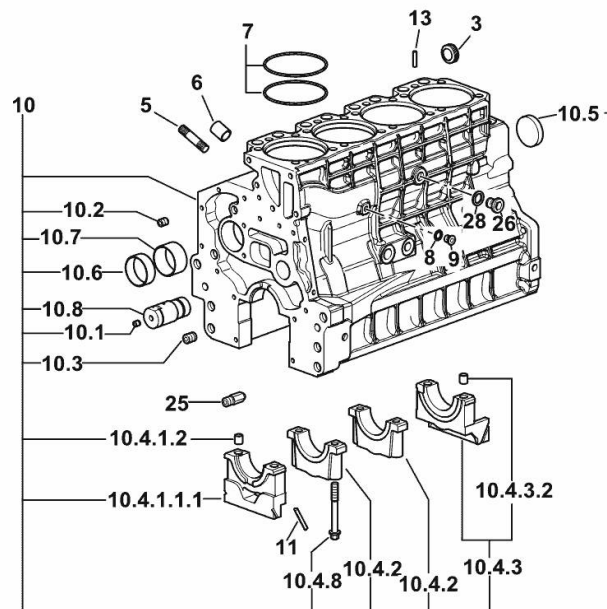

3	2.3199.312.2/20	1	plug m 35x1.5x9.5
5	2.0439.279.7	8	stud bolt m 8 p.1 x 25
6	2.1559.188.2	4	bush 11.4 x 14 x16
7	2.1539.259.0	8	special oil seal 107.62x2.62
8	2.1560.010.0	1	gasket 14.2 x 20
9	2.3199.292.0	1	plug 1/4" gas
10	0.014.9655.4/30	1	crankcase
10.1	2.3130.001.1	14	plug 1/8" gas
10.2	2.3130.002.1	4	plug 1/4" gas
10.3	2.3130.003.1	6	plug 3/8" gas
10.4.1.1.1	0.065.1112.7/10	1	support
10.4.1.2	2.1699.165.0	1	bush 12.3x15x16
10.4.2	0.065.1114.0/10	3	support
10.4.3	0.065.1116.3	1	support
10.4.3.2	2.1699.165.0	1	bush 12.3x15x16
10.4.8	0.065.1117.0	10	screw m 12 x 100
10.5	2.3179.012.0	1	plug 60
10.6	0.065.1140.0	4	special bushing 59X55X20
10.7	0.065.1141.0	1	special bushing 59X55X30
10.8	0.014.1340.0/10	1	pin mm 85
11	0.066.1152.0/10	4	gasket
13	2.1549.154.2	4	bush 4.8x5.8x16
25	0.013.4946.0/10	1	sprayer nozzle
26	2.3120.101.0	1	plug m 18 p.1.5
28	2.1560.014.0	1	washer 18.2 x 24

19_Q5011_00_0-A-001

MONOBLOC ENGINE-GEARBOX CONNECTING FLANGE

Fig.	P/n	QTY	Name
------	-----	-----	------

Notes:

[Rekord 80.4 2WD ->L10S704WXE45001] [Rekord 80.4 4WD ->L10S704WTE45001]

1	0.015.8814.0	1	flange
2	2.0112.511.2	8	screw m 14 p.2 x 30
3	2.0432.255.7	2	stud bolt m 12 p.1.75-1.25x25
4	2.1651.912.0	4	cylindrical plug 12x28
5	2.0512.404.7	2	screw

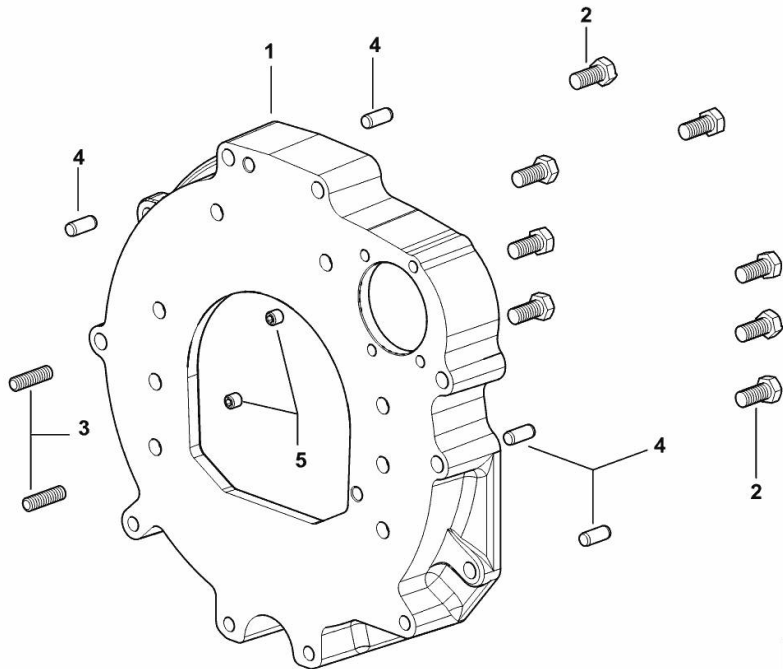

I9_38511_01_0-A-001

FITTING FOR ENGINE OIL PRESSURE SWITCH

Fig.	P/n	QTY	Name
------	-----	-----	------

Notes:

[Rekord 80.4 2WD ->L10S704WXE45001] [Rekord 80.4 4WD ->L10S704WTE45001]

100	2.3339.353.2/20	1	pipe fitting 12 p.1.5-18 p.1.5
101	2.1560.014.0	1	washer 18.2 x 24

19_37615_12_0-A-00

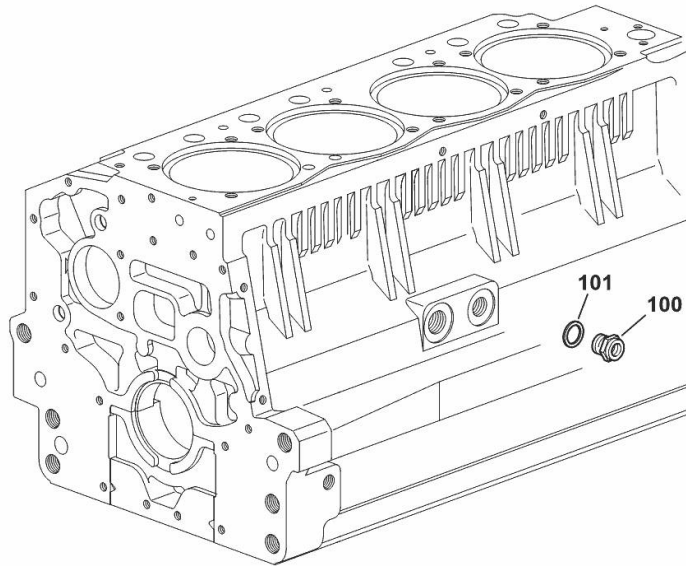

FITTING FOR ENGINE OIL PRESSURE SWITCH

Fig.	P/n	QTY	Name
------	-----	-----	------

Notes:

[Rekord 80.4 2WD ->L10S704WXE45001] [Rekord 80.4 4WD ->L10S704WTE45001]

1	2.3249.014.2	1	pipe fitting m 12 p.1.5
2	2.1560.008.0	3	gasket 12.2 x 18
3	2.3335.052.2	1	pipe union m 12 p.1.5

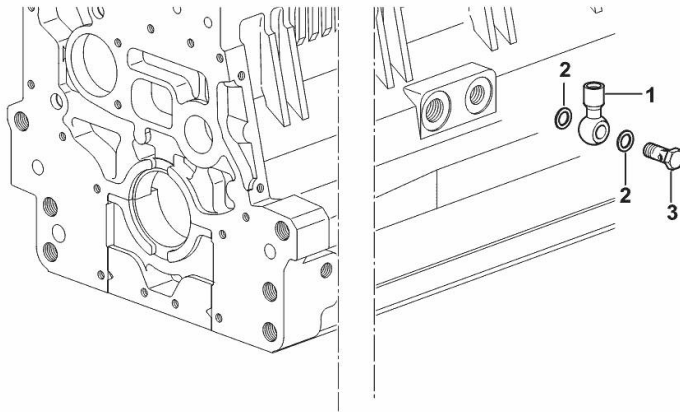

19_37615_07_0-A-001

SIDE PLUG FOR CYLINDER BLOCK

Fig.	P/n	QTY	Name
------	-----	-----	------

Notes:

[Rekord 80.4 2WD ->L10S704WXE45001] [Rekord 80.4 4WD ->L10S704WTE45001]

22	2.1560.017.0	1	gasket 22.2 x 27
23	2.3120.002.4	1	plug m 22 x 1.5

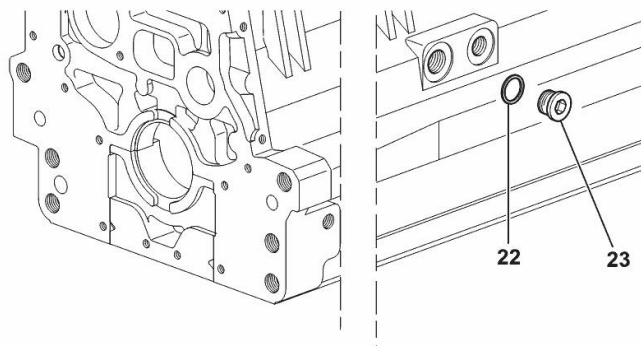

I9_33211_07_0-A-001

LOWER PLUG FOR CYLINDER BLOCKS

Fig.	P/n	QTY	Name
------	-----	-----	------

Notes:

[Rekord 80.4 2WD ->L10S704WXE45001] [Rekord 80.4 4WD ->L10S704WTE45001]

1	2.3130.003.1	2	plug 3/8" gas
---	--------------	---	---------------

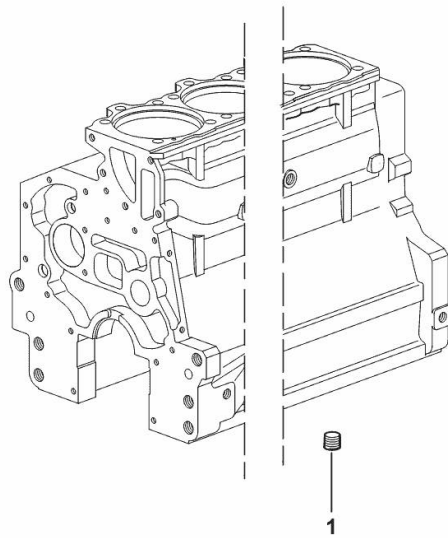

19_37511_06_0-A-001

CRANKSHAFT

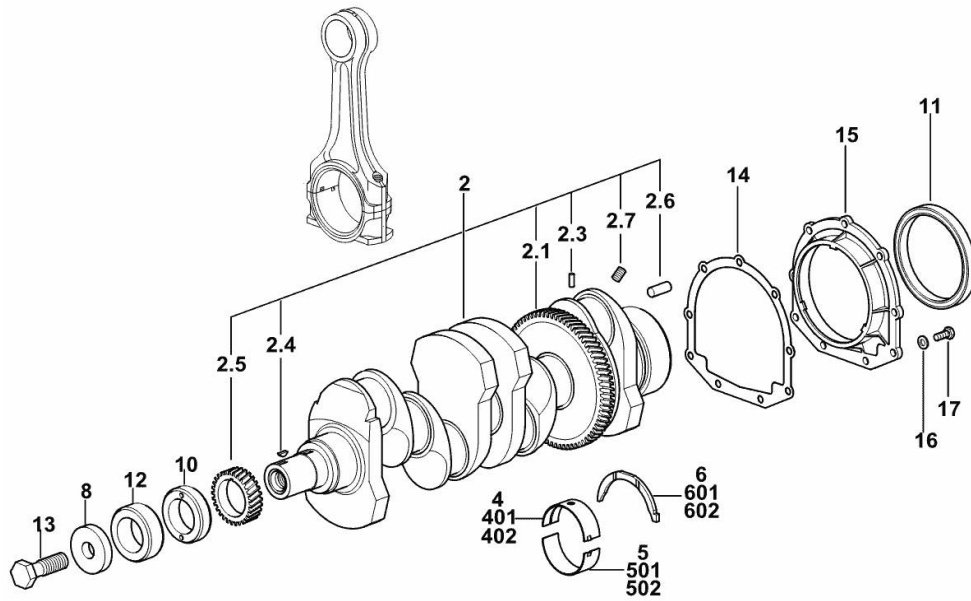

19_M7612_00_0-A-001

Fig.	P/n	QTY	Name
------	-----	-----	------

Notes:

[Rekord 80.4 2WD ->L10S704WXE45001] [Rekord 80.4 4WD ->L10S704WTE45001]

2	0.086.1210.3/40	1	crankshaft
2.1	0.065.1211.0/10	1	crown wheel
2.3	2.1630.608.0	1	pin 6x16
2.4	2.1720.006.0	1	key 4x6.5
2.5	0.065.1323.0/30	1	gear Z = 29
2.6	2.1651.915.0	1	pin 12x35
2.7	2.3130.001.1	4	plug 1/8" gas
4	0.065.1215.0/10	5	main half bushing STANDARD
5	0.065.1216.0/10	5	main half bushing STANDARD
6	0.065.1218.0	4	shim STANDARD
8	2.1599.524.7	1	washer 21x60x12
10	0.085.1248.0/20	1	hub
11	2.1529.073.0	1	special oil seal 110x130x13
12	0.014.7054.0	1	spacer
13	2.0399.144.7/10	1	screw m 20 p.1.5x51
14	0.065.1254.0/20	1	gasket
15	0.007.1711.0/10	1	cover
16	2.1475.002.2	9	conical washer 8
17	2.0112.207.2	9	screw m 8 p 1.25 x 20
401	0.065.1215.7	1	main half bushing - mm 0.25
402	0.065.1215.8	1	main half bushing - mm 0.50
501	0.065.1216.7	1	main half bushing - mm 0.25
502	0.065.1216.8	1	main half bushing - mm 0.50
601	0.065.1218.7	1	shim + mm 0.10
602	0.065.1218.8	1	shim + mm 0.15

Buy Now



Our support email:

ebooklibonline@outlook.com