

# X 100

## Excavator

## Service Manual

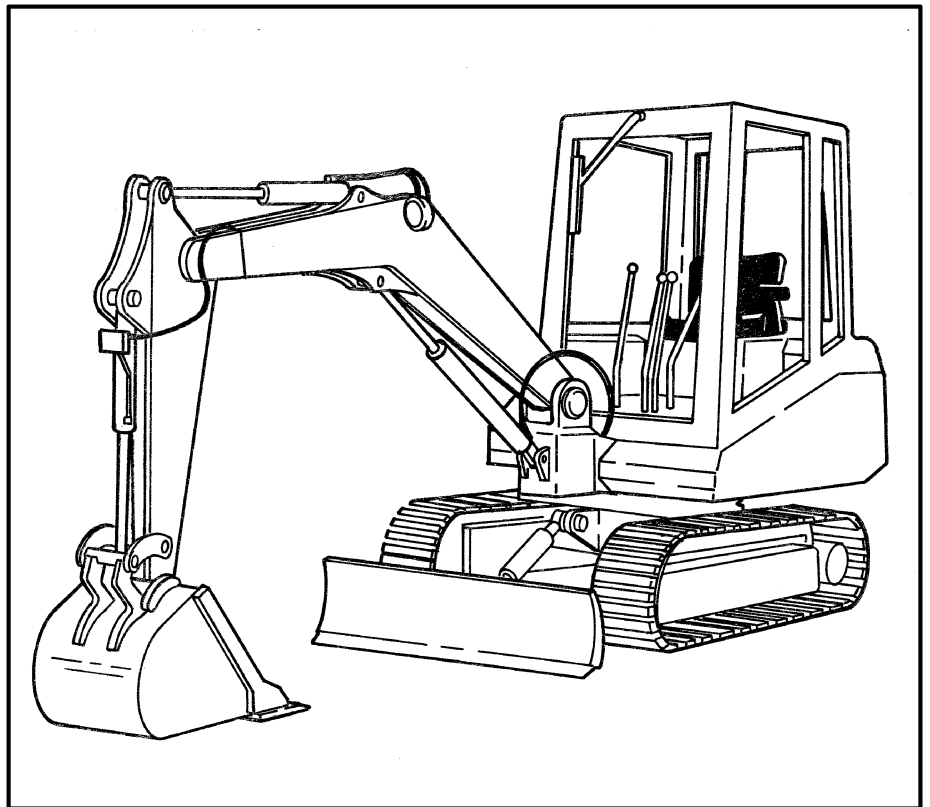
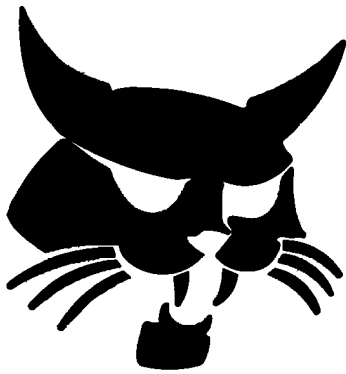

**MELROE**  
**INGERSOLL-RAND**

6570483(3-87)

Printed in U.S.A.



© Melroe Company 1987

# CONTENTS

	No. of page
<b>10 ENGINE</b>	
11 STRUCTURE AND FUNCTION .....	11-1
12 TESTING AND ADJUSTING .....	12-1
13 DISASSEMBLY AND ASSEMBLY .....	13-1
<b>20 POWER TRAIN</b>	
21 STRUCTURE AND FUNCTION .....	21-1
23 DISASSEMBLY AND ASSEMBLY .....	23-1
24 MAINTENANCE STANDARD .....	24-1
<b>30 UNDERCARRIAGE</b>	
31 STRUCTURE AND FUNCTION .....	31-1
33 DISASSEMBLY AND ASSEMBLY .....	33-1
34 MAINTENANCE STANDARD .....	34-1
<b>60 HYDRAULIC SYSTEM</b>	
61 STRUCTURE AND FUNCTION .....	61-1
62 TESTING AND ADJUSTING .....	62-1
63 DISASSEMBLY AND ASSEMBLY .....	63-1
64 MAINTENANCE STANDARD .....	64-1
<b>70 WORK EQUIPMENT</b>	
71 STRUCTURE AND FUNCTION .....	71-1
73 DISASSEMBLY AND ASSEMBLY .....	73-1
74 MAINTENANCE STANDARD .....	74-1
<b>80 ELECTRIC AND ELECTRONIC SYSTEM</b>	
81 STRUCTURE AND FUNCTION .....	81-1
<b>90 OTHERS</b>	
93 DISASSEMBLY AND ASSEMBLY .....	93-1



## IMPORTANT SAFETY NOTICE

Proper service and repair is extremely important for the safe operation of your machine. The service and repair techniques recommended and described in this manual are both effective and safe methods of operation. Some of these operations require the use of tools specially designed for the purpose.

To prevent injury to workers, the symbol  is used to mark safety precautions in this manual. The cautions accompanying these symbols should always be followed carefully. If any dangerous situation arises or could possibly arise, first consider safety, and take the necessary actions to deal with the situation.



## SAFETY

### GENERAL PRECAUTIONS

Mistakes in operation are extremely dangerous. Read the Operation and Maintenance Manual carefully BEFORE operating the machine.

1. Before carrying out any greasing or repairs, read all the precautions given on the decals which are on the machine.
2. When carrying out any operation, wear safety shoes and helmet. Do not wear loose work clothes, or clothes with buttons missing.  
  
Wear safety glasses when using tools.
3. If welding repairs are needed, have a trained, experienced welder carry out the work. When welding wear welding gloves, apron, glasses, cap and other clothes suited for welding work.
4. When doing any operation with two or more workers, agree on the operating procedure before starting. Inform your fellow workers before starting any step of the operation. Before starting work, hang UNDER REPAIR signs on the controls in the operator's compartment.
5. Keep all tools in good condition and learn the correct way to use them.

6. Determine a place in the workshop to keep tools and removed parts. Keep the tools and parts in their correct places. Keep the work area clean and make sure that there is no dirt or oil on the floor. Smoke only in the areas provided for smoking. Never smoke while working.

### PREPARATIONS FOR WORK

7. Before adding oil or making any repairs, park the machine on hard, level ground, and block the wheels or tracks to prevent the machine from moving.
8. Before starting work, lower blade, ripper, bucket or any other work equipment to the ground. If this is not possible, insert the safety pin or use blocks to prevent the work equipment from falling. In addition, be sure to lock all the control levers and hang warning signs on them.
9. When disassembling or assembling, support the machine with blocks, or jackstands before starting work.
10. Remove all mud and oil from the steps or other places used to get on and off the machine. Use the handrails, ladders or steps when getting on or off the machine. If it is impossible to use the handrails, ladders or steps, use a stand to provide safe footing.

## PRECAUTIONS DURING WORK

11. When removing the oil filler cap, drain plug or hydraulic pressure measuring plugs, loosen them slowly to prevent oil from spurting out. Before disconnecting or removing components of the oil, water or air circuits, first remove all pressure from the circuit.
12. Check that machine is cool before working on the oil or coolant circuits.
13. Before starting work, remove the leads from the battery. Remove the lead from the negative (–) terminal first.
14. When raising heavy components, use a hoist or crane.  
  
Check that wire rope, chains and hooks are free from damage.  
  
Always use lifting equipment which has ample capacity.  
  
Install the lifting equipment at the correct places. Use a hoist or crane and operate slowly to prevent the component from hitting any other part. Do not work on any part supported only by the hoist or crane.
15. When removing covers which are under pressure, leave two bolts in position on opposite sides. Slowly release the pressure, then slowly loosen the bolts to remove.
16. When removing components, be careful not to damage the wiring. Damaged wiring can cause electrical fires.
17. Always clean up spilled fuel or oil. Keep heat, flames, sparks or lighted tobacco away from fuel and oil. Failure to use care around combustibles can cause explosion or fire which can result in injury or death.
18. Do not use gasoline to wash parts, use commercial solvent.
19. When installing high pressure hose, make sure that they are not twisted. Damaged tubes are dangerous, be careful when installing tubes for high pressure circuits.
20. Take care when removing or installing tracks. A tack can separate suddenly, so never let anyone stand at either end of the track.

# FOREWORD

This shop manual has been prepared as an aid to improve the quality of repairs by giving the serviceman an accurate understanding of the product and by showing him the correct way to perform repairs and make judgements. Make sure you understand the contents of this manual and use it fully at every opportunity.

This shop manual contains the necessary technical information for operations performed in a service workshop.

For ease of understanding, the manual is divided into chapters for each main group of components; these chapters are further divided into the following sections.

## STRUCTURE AND FUNCTION

This section explains the structure and function of each component. It serves not only to give an understanding of the structure, but also serves as reference material for troubleshooting.

## TESTING AND ADJUSTING

This section explains checks to be made before and after performing repairs, as well as adjustments to be made at completion of the checks and repairs.

Troubleshooting charts correlating "Problems" to "Causes" are also included in this section.

## DISASSEMBLY AND ASSEMBLY

This section explains the order to be followed when removing, installing, disassembling or assembling each component, as well as precautions to be taken for these operations.

## MAINTENANCE STANDARD



This section gives the judgement standards when inspecting disassembled parts.





### NOTICE

**The specifications contained in this shop manual are subject to change at any time and without any advance notice. Contact your dealer for the latest information.**

## SYMBOLS

So that the shop manual can be of ample practical use, important places for safety and quality are marked with the following symbols.

Symbol	Item	Remarks
	Safety	Special safety precautions are necessary when performing the work.
	Caution	Special technical precautions or other precautions for preserving standards are necessary when performing the work.



	Weight	Weight of parts or systems. Caution necessary when selecting hoisting wire, or when working posture is important, etc.
	Tightening torque	Places that require special attention for the tightening torque during assembly.
	Coat	Places to be coated with adhesives and lubricants etc.
	Oil, water	Places where oil, water or fuel must be added, and the capacity.
	Drain	Places where oil or water must be drained, and quantity to be drained.

## STANDARD TIGHTENING TORQUE



## 1. STANDARD TIGHTENING TORQUE OF BOLTS AND NUTS

The following charts give the standard tightening torques of bolts and nuts. Exceptions are given in sections of "Disassembly and Assembly".

Thread diameter of bolt (mm)	Width across flat (mm)		
		kgm	Nm
6	10	$1.35 \pm 0.15$	$13.2 \pm 1.4$
8	13	$3.2 \pm 0.3$	$31.4 \pm 2.9$
10	17	$6.7 \pm 0.7$	$65.7 \pm 6.8$
12	19	$11.5 \pm 1.0$	$112 \pm 9.8$
14	22	$18.0 \pm 2.0$	$177 \pm 19$
16	24	$28.5 \pm 3$	$279 \pm 29$
18	27	$39 \pm 4$	$383 \pm 39$
20	30	$56 \pm 6$	$549 \pm 58$
22	32	$76 \pm 8$	$745 \pm 78$
24	36	$94.5 \pm 10$	$927 \pm 98$
27	41	$135 \pm 15$	$1320 \pm 140$
30	46	$175 \pm 20$	$1720 \pm 190$
33	50	$225 \pm 25$	$2210 \pm 240$
36	55	$280 \pm 30$	$2750 \pm 290$
39	60	$335 \pm 35$	$3280 \pm 340$

This torque table does not apply to the bolts with which nylon packings or other non-ferrous metal washers are to be used, or which require tightening to otherwise specified torque.

★ Nm (newton meter):  $1\text{Nm} \cong 0.1\text{ kgm}$

## 2. TIGHTENING TORQUE OF SPLIT FLANGE BOLTS

Use these torques for split flange bolts.

Thread diameter of bolt (mm)	Width across flats (mm)	Tightening torque	
		kgm	Nm
10	14	$6.7 \pm 0.7$	$65.7 \pm 6.8$
12	17	$11.5 \pm 1$	$112 \pm 9.8$
16	22	$28.5 \pm 3$	$279 \pm 29$

## STANDARD TIGHTENING TORQUE



### 3. TIGHTENING TORQUE FOR NUTS OF FLARED

Use these torques for nut part of flared.

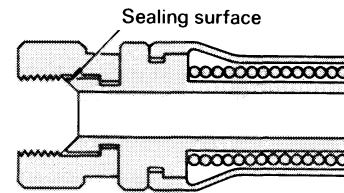

FS0068

Thread diameter of nut part (mm)	Width across flats of nut part (mm)	Tightening torque	
		kgm	Nm
14	19	2.5 ± 0.5	24.5 ± 4.9
18	24	5 ± 2	49 ± 19.6
22	27	8 ± 2	78.5 ± 19.6
24	32	14 ± 3	137.3 ± 29.4
30	36	18 ± 3	176.5 ± 29.4
33	41	20 ± 5	196.1 ± 49
36	46	25 ± 5	245.2 ± 49
42	55	30 ± 5	294.2 ± 49



## COATING MATERIALS

The recommended coating materials prescribed in the Manuals are listed below.

Nomenclature	code	Applications
Adhesives	LT-1A	Used to apply rubber pads, rubber gaskets, and cork plugs.
	LT-1B	Used to apply resin, rubber, metallic and non-metallic parts when a fast, strong seal is needed.
	LT-2*	Preventing bolts, nuts and plugs from loosening and leaking oil.
	LT-3	Provides an airtight, electrically insulating seal. Used for aluminum surfaces.
Liquid gasket	LG-1	Used with gaskets and packings to increase sealing effect.
	LG-3	Heat-resistant gasket for precombustion chambers and exhaust piping.
	LG-4	Used by itself on mounting surfaces on the final drive and transmission cases. (Thickness after tightening: 0.07 – 0.08 mm)
	LG-5	Used by itself to seal grease fittings, tapered screw fittings and tapered screw fittings in hydraulic circuits of less than 50 mm in diameter.
Antifriction compound (Lubricant including molybdenum disulfide)	LM-P	Applied to bearings and taper shafts to facilitate press-fitting and to prevent sticking, burning or rusting.
Grease (Lithium grease)	G2-LI	Applied to bearings, sliding parts and oil seals for lubrication, rust prevention and facilitation of assembling work.
Vaseline	—	Used for protecting battery electrode terminals from corrosion.

\*LT-2 is also called LOCTITE in the shop manuals.

## ELECTRIC WIRE CODE

In the wiring diagrams, various colors and symbols are employed to indicate the thickness of wires.

This wire code table will help you understand WIRING DIAGRAMS.

Example: 05WB indicates a cable having a nominal number 05 and white coating with black stripe.

## CLASSIFICATION BY THICKNESS

Nominal number	Copper wire			Cable O.D. (mm)	Current rating (A)	Applicable circuit
	Number strands	Dia. of strands (mm)	Cross section (mm <sup>2</sup> )			
01	11	0.32	0.88	2.4	12	Starting, lighting, signal etc.
02	26	0.32	2.09	3.1	20	Lighting, signal etc.
05	65	0.32	5.23	4.6	37	Charging and signal
15	84	0.45	13.36	7.0	59	Starting (Glow plug)
40	85	0.80	42.73	11.4	135	Starting
60	127	0.80	63.84	13.6	178	Starting
100	217	0.80	109.1	17.6	230	Starting

## CLASSIFICATION BY COLOR AND CODE

Priority	Circuits		Starting	Charging	Lighting	Signal	Instrument	Other
	Classification							
1	Primary	Code	B	W	R	G	Y	L
		Color	Black	White	Red	Green	Yellow	Blue
2	Auxiliary	Code	BW	WR	RW	GW	YR	LW
		Color	Black & White	White & Red	Red & White	Green & White	Yellow & Red	Blue & White
3	Auxiliary	Code	BY	WB	RB	GR	YB	LR
		Color	Black & Yellow	White & Black	Red & Black	Green & Red	Yellow & Black	Blue & Red
4	Auxiliary	Code	BR	WL	RY	GY	YG	LY
		Color	Black & Red	White & Blue	Red & Yellow	Green & Yellow	Yellow & Green	Blue & Yellow
5	Auxiliary	Code	—	WY	RG	GB	YL	LB
		Color	—	White & Yellow	Red & Green	Green & Black	Yellow & Blue	Blue & Black
6	Auxiliary	Code	—	WG	RL	GL	YW	
		Color	—	White & Green	Red & Blue	Green & Blue	Yellow & White	



# WEIGHT TABLE

 This weight table is a guide for use when transporting or handling components.

Unit:kg

Machine model	100
Engine assembly	198.6
• Engine (including engine mount)	182.6
• P.T.O	8.9
• Hydraulic pump (triple gear pump)	8.1
Radioator assembly	12.6
Hydraulic tank (dry)	40.5
Fuel tank (dry)	19.6
Operator's cab	162
Revolving frame	365
Swing machinery	28.1
Swing motor (including brake valve)	16
Travel motor (with reduction gear)	46.5 × 2
6-spool control valve	16
2-spool control valve (PC20-6)	8.3
3-spool control valve (PC30-6)	
Center swivel joint assembly	20.5
Counterweight	251
Track frame assembly	552
• Track frame	348
• Track roller	8.2 × 8
• Recoil spring assembly	10.2 × 2
• Idler assembly	28 × 2
• Sprocket	8.3 × 2
• Swing circle assembly	45.6
Track shoe assembly	336
• Standard Track shoe (300 mm wide)	
Boom assembly	106
Arm assembly	57
Bucket assembly	72

# WEIGHT TABLE (Cont'd)

Unit:kg

Machine model	100
Boom cylinder assembly	29.0 (CP) 29.2 (CB)
Arm cylinder assembly	21.5
Bucket cylinder assembly	17.0
Boom swing cylinder assembly	29.0
Blade cylinder assembly	19.1
Swing bracket assembly	66.0 (CP) 63.5 (CB)
Blade assembly	150

# CAPACITY TABLE OF FUEL, COOLANT AND LUBRICANTS (S/N 11999 & Below)

## PROPER SELECTION OF FUEL, COOLANT AND LUBRICANTS

RESERVOIR	KIND OF FLUID	AMBIENT TEMPERATURE					CAPACITY (ℓ)	
		14 -10	32 0	50 10	68 20	86° F 30° C	Specified	Refill
Engine oil pan	Engine oil	SAE 30					4.2	4.2
		SAE 10W						
Swing machinery case							1.5	1.5
Final drive case (each)							0.45	0.45 (100)
							0.5	0.5 (100)
Track roller		SAE 30					40cc	40cc
Idler							20cc	20cc
Hydraulic tank		SAE 10W					51	36
		SAE 10W-30						
		SAE 15W-40						
Fuel tank	Diesel fuel	*				45	-	
		ASTM D975 No. 2						
Cooling system	Water	Add antifreeze					5	-

\* ASTM D975 No. 1

NOTE: Black Gold can be used in hydraulic system.

# TABLE OF OIL AND COOLANT QUANTITIES (S/N 12001 & Above)

## PROPER SELECTION OF FUEL, COOLANT AND LUBRICANTS

RESERVOIR	KIND OF FLUID	AMBIENT TEMPERATURE					CAPACITY (ℓ)	
		14 -10	32 0	50 10	68 20	86°F 30°C	Specified	Refill
Engine oil pan	Engine oil	SAE 30					4.2	4.2
		SAE 10W						
		SAE 10W-30						
Swing machinery case Final drive case(each)	Engine oil						1.5	1.3
Track roller (one) Idler (one side)		SAE 30					—	—
							—	—
Hydraulic tank	Engine oil	SAE 10W					48	35
		SAE 10W-30						
		SAE 15W-40						
Fuel tank	Diesel fuel	*					50	—
		ASTM D975 No. 2						
Cooling system	Water	Add antifreeze					5.0	5.0

\* ASTM D975 No. 1

ASTM: American Society of Testing and Material

SAE: Society of Automotive Engineers

Specified capacity: Total amount of oil including oil for components and oil in piping.

Refill capacity: Amount of oil needed to refill system during normal inspection and maintenance.

### NOTE:

(1) When fuel sulphur content is less than 0.5%, change oil in the pan every periodic maintenance hours described in operation and maintenance manual. Change oil according to the following table if fuel sulphur content is above 0.5%.

Fuel sulphur content	Change interval of oil in engine oil pan
0.5 to 1.0%	1/2 of regular interval
Above 1.0%	1/4 of regular interval

(2) When starting the engine in an atmospheric temperature of lower than 0°C, be sure to use engine oil of SAE10W, SAE10W-30 and SAE15W-40, even though and atmospheric temperature goes up to 10°C more or less in the day time.

(3) Use API classification CD as engine oil and if API classification CC, reduce the engine oil change interval to half.

---

# ENGINE

## **11** STRUCTURE AND FUNCTION

---



Engine mount.....	11-2
Radiator .....	11-3
Power take-off system.....	11-4
Fuel tank and piping .....	11-5
Engine control .....	11-6

# ENGINE MOUNT

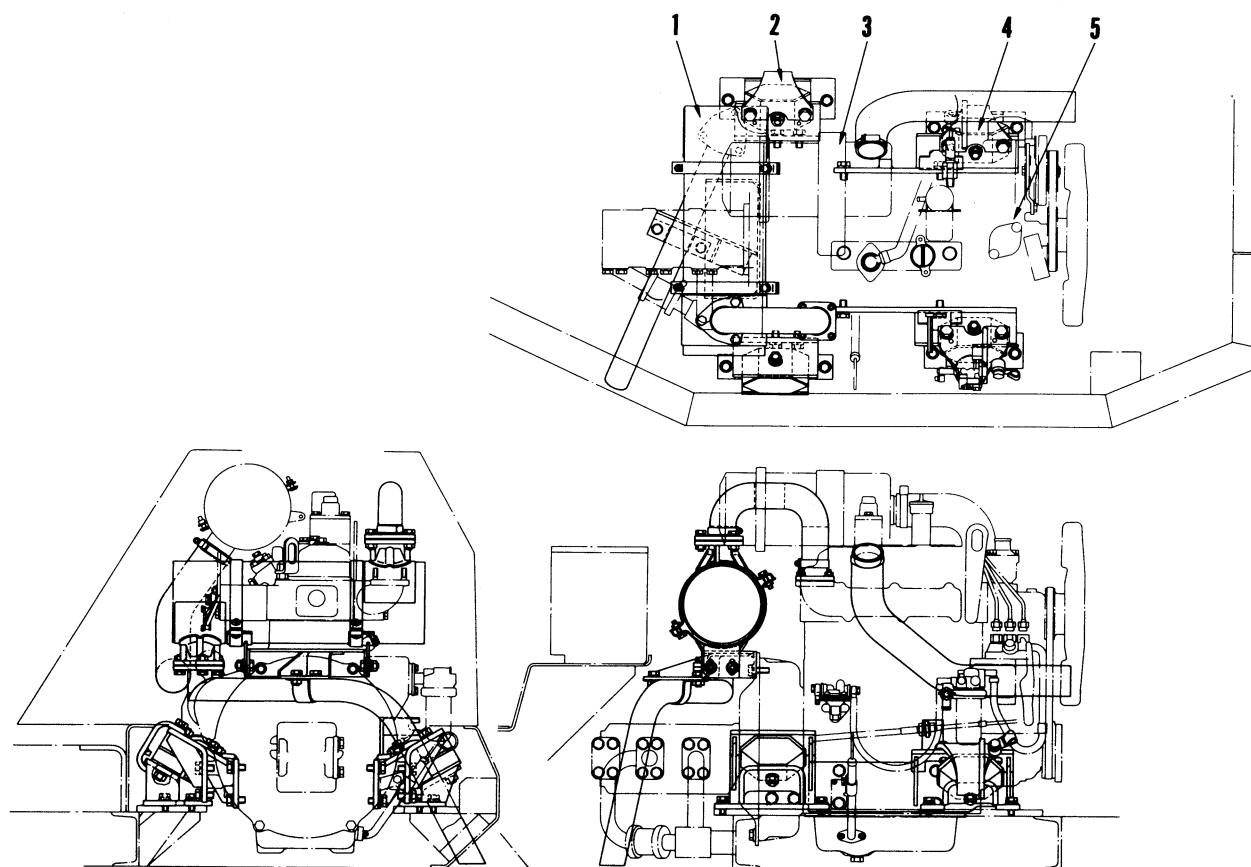

20RF5003

1. Muffler
2. Rear bracket
3. Air cleaner
4. Front bracket
5. Engine

Thank you so much for reading.  
Please click the “Buy Now!”  
button below to download the  
complete manual.



After you pay.

You can download the most  
perfect and complete manual in  
the world immediately.

Our support email:

[ebooklibonline@outlook.com](mailto:ebooklibonline@outlook.com)