

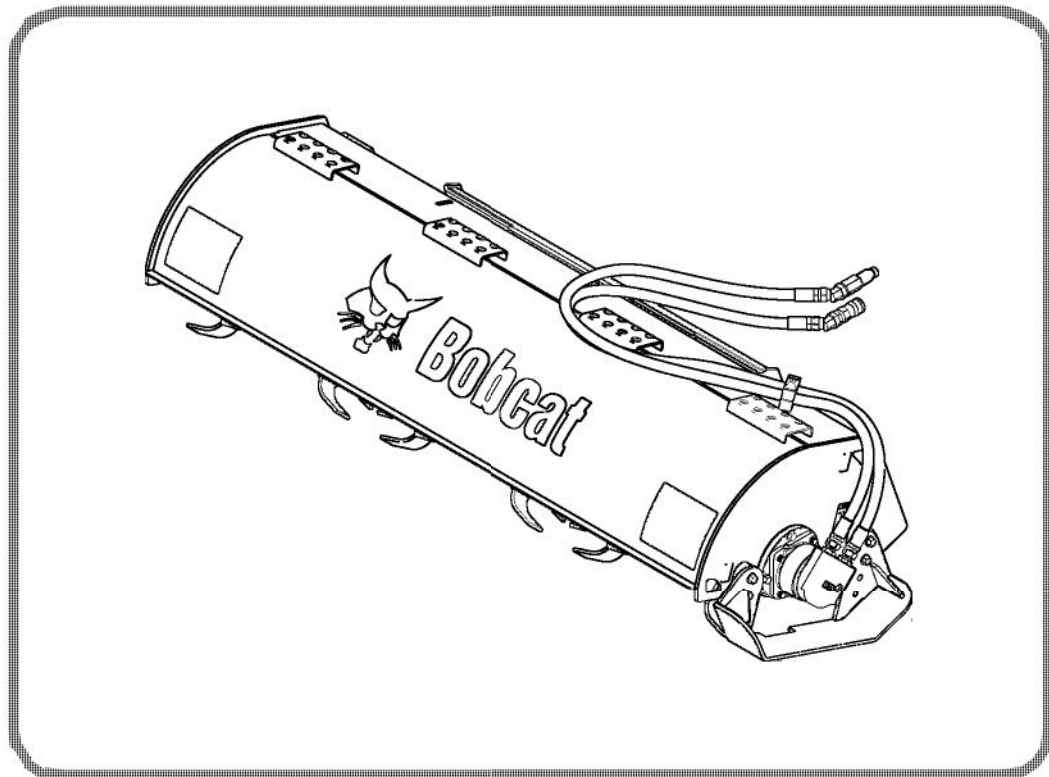

Bobcat®

Service Manual Tiller

(40 Tiller) S/N APFW00101 & Above
(62 Tiller) S/N 055200101 & Above
(76 Tiller) S/N 055100101 & Above



Dealer Copy -- Not for Resale



MAINTENANCE SAFETY



WARNING







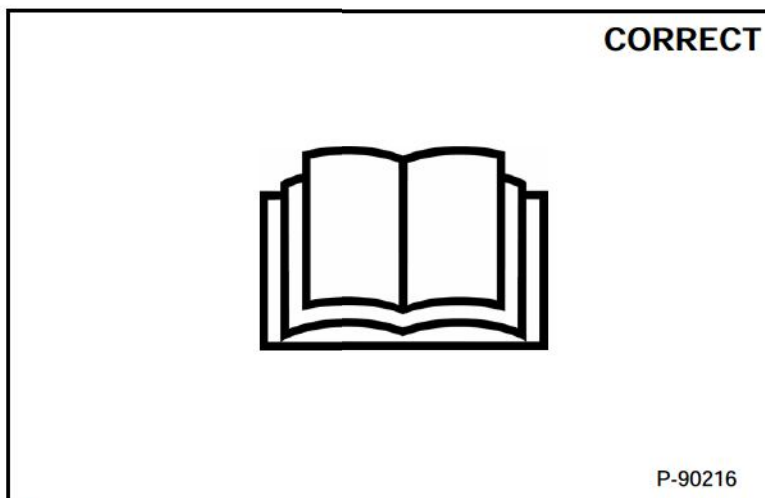

Instructions are necessary before operating or servicing machine. Read and understand the Operation & Maintenance Manual, Operator's Handbook and signs (decals) on machine. Follow warnings and instructions in the manuals when making repairs, adjustments or servicing. Check for correct function after adjustments, repairs or service. Untrained operators and failure to follow instructions can cause injury or death.

W-2003-0807



Safety Alert Symbol: This symbol with a warning statement, means: "Warning, be alert! Your safety is involved!" Carefully read the message that follows.



-  Never service attachments / implements without instructions. See Operation & Maintenance Manual and Attachment / Implement Service Manual.
-  Cleaning and maintenance are required daily.
-  Never service or adjust attachment / implement with the engine running unless instructed to do so in manual.
-  Always lower the attachment / implement to the ground before lubricating or servicing.
-  Avoid contact with leaking hydraulic fluid or diesel fuel under pressure. It can penetrate skin or eyes.
-  Stop, cool and clean engine of flammable materials before checking fluids.
-  Keep body, loose objects and clothing away from moving parts, electrical contacts, hot parts and exhaust.
-  Safety glasses are needed for eye protection from electrical arcs, battery acid, compressed springs, fluids under pressure and flying debris or when tools are used. Use eye protection approved for type of welding.

Dealer Copy -- Not for Resale

MSW30-0409

CONTENTS

SAFETY AND MAINTENANCE	10-01
HYDRAULIC SYSTEM	20-01
MAINFRAME	30-01
SPECIFICATIONS	SPEC-01
ALPHABETICAL INDEX	INDEX-01

FOREWORD

SERIAL NUMBER LOCATION	1-7
Attachment Serial Number	1-7
DELIVERY REPORT	1-7
ATTACHMENT IDENTIFICATION	1-8
40 Tiller	1-8
62 Tiller And 76 Tiller	1-9

SERIAL NUMBER LOCATION

Attachment Serial Number

Figure 1



Always use the serial number [Figure 1] of the tiller when requesting service information or when ordering parts. Early or later models (identification made by serial number) may use different parts, or it may be necessary to use a different procedure in doing a specific service operation.

DELIVERY REPORT

Figure 2

A scan of a Bobcat 'Delivery Report Attachment' form. The form includes fields for 'Machine Number' and 'Serial Number'. It contains a 'WARNING' section with 15 numbered items, such as 'Check for fuel and oil leakage' and 'Check for proper operation of safety features'. At the bottom, there are lines for 'Dealer Representative Signature & Title' and 'Date'. The number 'NA7494' is printed in the bottom right corner of the form.

The delivery report [Figure 2] must be completed by the dealer and signed by the owner or operator when the Bobcat tiller is delivered. An explanation of the form must be given to the owner.

Dealer Copy -- Not for Resale

ATTACHMENT IDENTIFICATION

40 Tiller

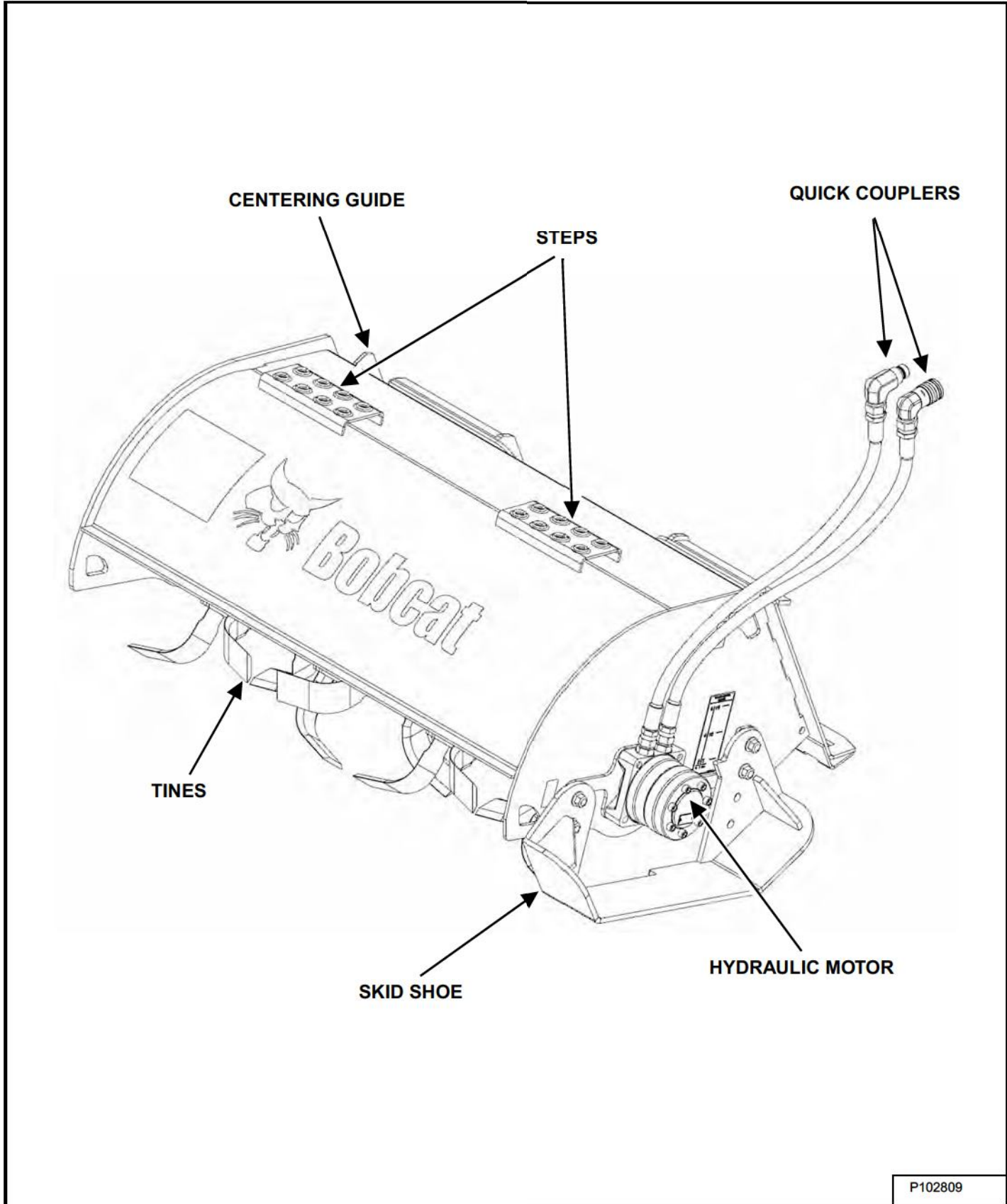

Dealer Copy -- Not for Resale

ATTACHMENT IDENTIFICATION (CONT'D)

62 Tiller And 76 Tiller

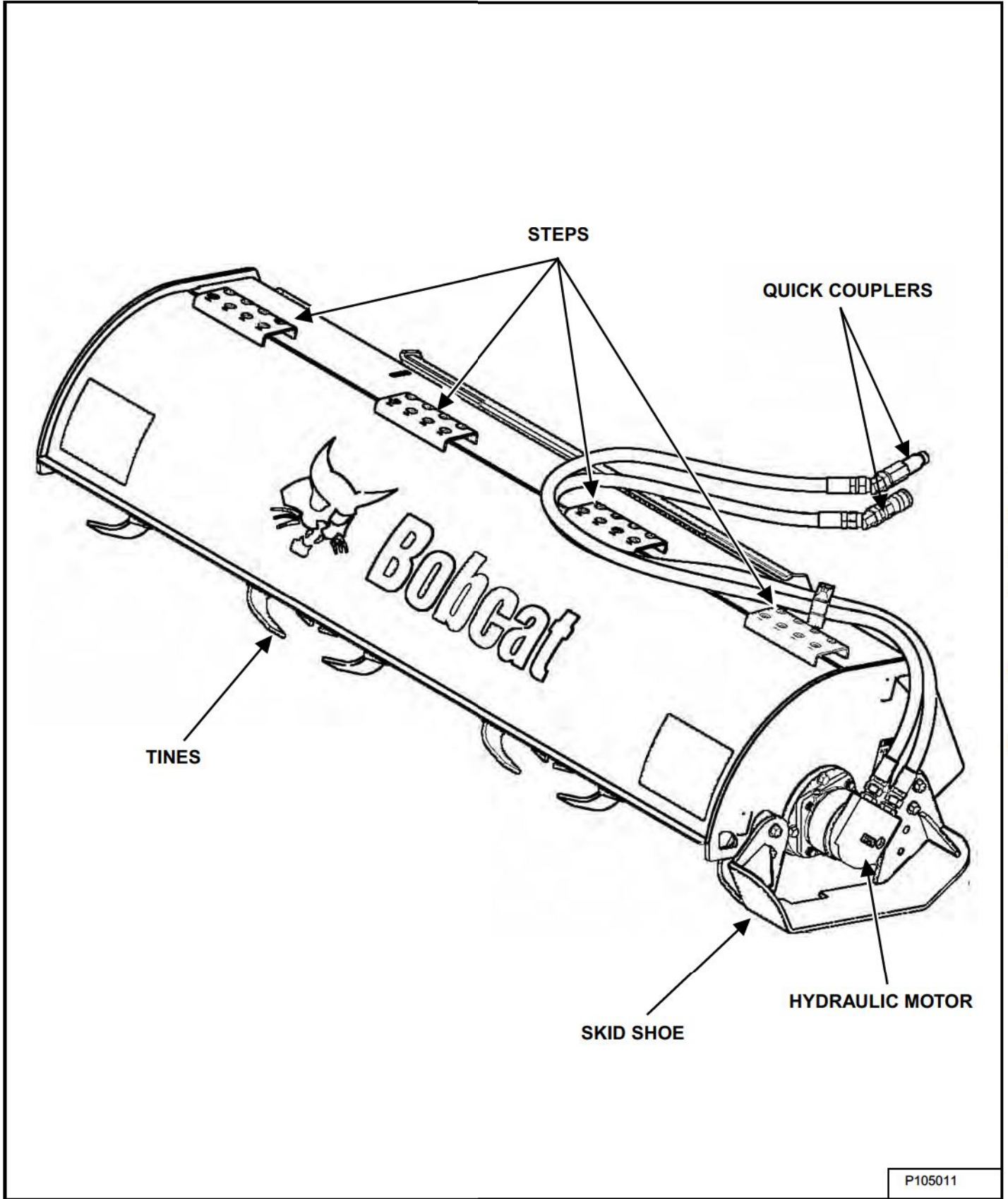

Dealer Copy -- Not for Resale

P105011

SAFETY AND MAINTENANCE

TROUBLESHOOTING	10-10-1
Chart	10-10-1
DAILY INSPECTION	10-20-1
Attachment Mounting Frame	10-20-1
Bob-Tach™	10-20-1

TROUBLESHOOTING

Chart

 WARNING	<p>Instructions are necessary before operating or servicing machine. Read and understand the Operation & Maintenance Manual, Operator's Handbook and signs (decals) on machine. Follow warnings and instructions in the manuals when making repairs, adjustments or servicing. Check for correct function after adjustments, repairs or service. Untrained operators and failure to follow instructions can cause injury or death.</p> <p style="text-align: right;">W-2003-0807</p>
--	--

If the attachment is not working correctly, check the hydraulic system of the machine thoroughly before making any repairs on the attachment. Attachment problems can be affected by a hydraulic system that is not operating to specifications. Connect a flow meter to the machine to check the hydraulic pump output, relief valve setting and tube lines to check flow and pressure. (See the machine's Service Manual for the correct procedure to connect the flow meter.)

Use the following troubleshooting chart to locate and correct problems which most often occur with the attachment.

PROBLEM	CAUSE	CORRECTION
Tiller will not function.	Hydraulics hoses improperly connected.	Check the hydraulic quick couplers to make sure they are connected properly.
	Auxiliary hydraulics not engaged.	Engage auxiliary hydraulics. (See the machine's Operation & Maintenance Manual and Operator's Handbook for correct procedure.)
Tiller leaves an uneven finish (half smooth, half rough).	Tiller tines are either missing, or are worn.	Replace broken tines. Be sure all tines are present.
Tiller leaves a rough finish.	Tiller is being operated at low rpm's.	Increase machine rpm's.
	Tiller tines are either missing, or are worn.	Replace broken tines. Be sure all tines are present.
	Tiller is traveling too fast.	Decrease the rate of travel.
Tiller operation causes the machine to vibrate roughly.	Tiller is operating in the wrong direction.	Check to make sure tiller shaft is rotating in the opposite direction of travel.
	Tiller is traveling too fast.	Decrease the rate of travel.
	Machine arms / boom not positioned in cradle.	Lower machine arms / boom fully.

Dealer Copy -- Not for Resale

DAILY INSPECTION

Attachment Mounting Frame

Figure 10-20-1

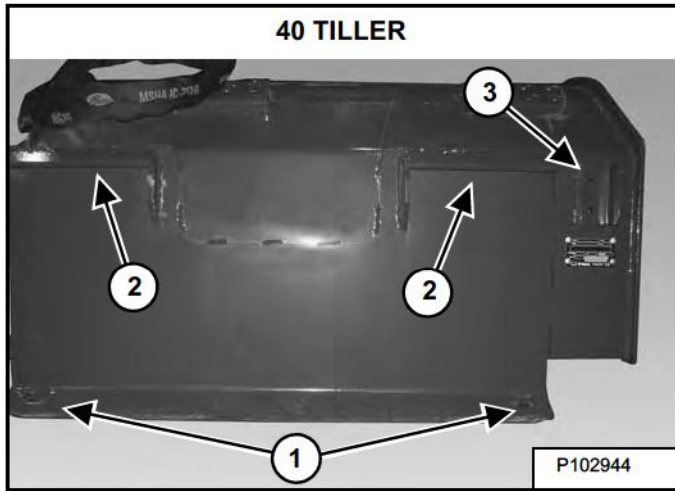
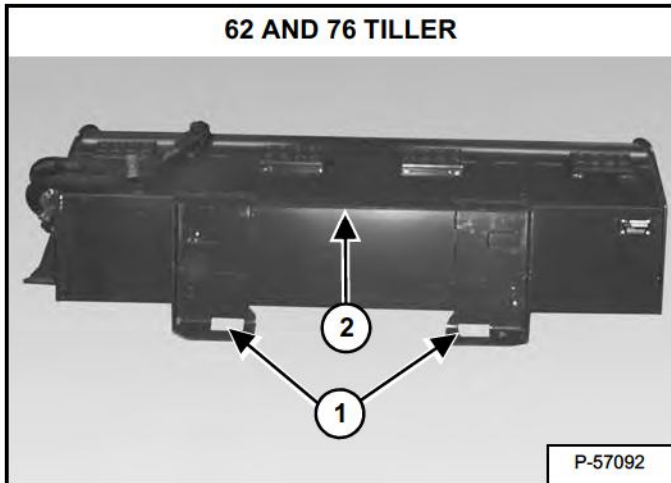

Figure 10-20-2



Inspect the Bob-Tach™ wedge mounts (Item 1), mounting flange (Item 2) [Figure 10-20-1] or [Figure 10-20-2] and all welds on the tiller for wear and damage each time the tiller is removed from the machine.

Inspect the Bob-Tach centering guide (Item 3) [Figure 10-20-1] (40 tiller only) for damage.

Frequently inspect the tiller to ensure that all components are secure and that all bolts and nuts are thoroughly tightened.

Bob-Tach™

Hand Lever Bob-Tach



AVOID INJURY OR DEATH

The Bob-Tach wedges must extend through the holes in the attachment mounting frame. Levers must be fully down and locked. Failure to secure wedges can allow attachment to come off.

W-2715-0208

Figure 10-20-3

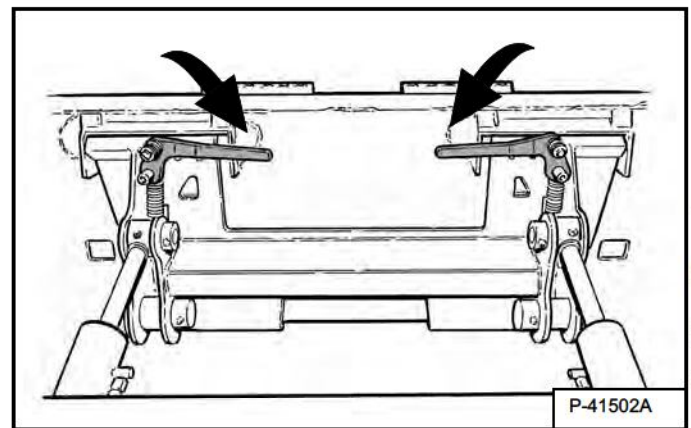

Push down on the Bob-Tach levers until they are fully engaged in the locked position [Figure 10-20-3] (wedges fully extended through the attachment mounting frame holes).

The levers and wedges must move freely [Figure 10-20-3].

Dealer Copy -- Not for Resale

DAILY INSPECTION (CONT'D)

Bob-Tach (Cont'd)

Hand Lever Bob-Tach (Cont'd)

Figure 10-20-4

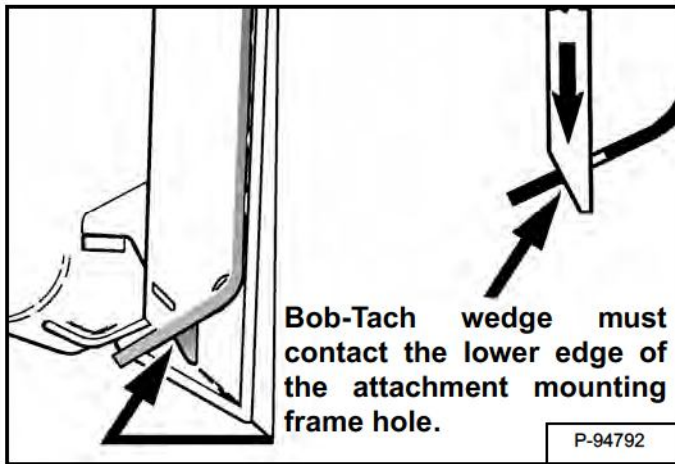

The wedges must extend through the holes in the attachment mounting frame, securely fastening the attachment to the Bob-Tach [Figure 10-20-4].

NOTE: If the wedge does not contact the lower edge of the hole, the attachment will be loose and can come off the Bob-Tach.

Inspect the mounting frame on the attachment. (See the machine's Operation & Maintenance Manual for inspecting the Bob-Tach). Replace any parts that are damaged, bent or missing. Keep all fasteners tight. Look for cracked welds. Contact your Bobcat dealer for repair or replacement parts.

Lubricate the wedges. (See the machine's Operation & Maintenance Manual for the correct procedure.)

Thank you so much for reading.
Please click the “Buy Now!”
button below to download the
complete manual.



After you pay.

You can download the most
perfect and complete manual in
the world immediately.

Our support email:

ebooklibonline@outlook.com