



# Service Manual

## Chassis & Mast

## MC/FC

**GP15N** T25C-50001-up  
**GP15ZN** T34-50011-up  
**GP18N** T25C-70001-up  
**GP18ZN** T34-70001-up  
**GP20CN** T34-20001-up  
**GP20N** T17D-00011-up  
**GP20ZN** T35-00011-up  
**GP25N** T17D-50001-up  
**GP25ZN** T35-50001-up  
**GP30N** T13F-30011-up  
**GP35AN** T13F-50001-up

**GPE15N** T25C-58001/68001-up  
**GPE15ZN** T34-58011/68001-up  
**GPE18N** T25C-78001/88001-up  
**GPE18ZN** T34-78001/88001-up  
**GPE20CN** T34-28001/38001-up  
**GPE20N** T17D-08011/18001-up  
**GPE20ZN** T35-08011/18001-up  
**GPE25N** T17D-58001/68001-up  
**GPE25ZN** T35-58001/68001-up  
**GPE30N** T13F-38011/48001-up  
**GPE35AN** T13F-58001/68001-up

**DP15N** T16D-50001/60001-up  
**DP18N** T16D-70001/80001-up  
**DP20CN** T16D-85001/87001-up  
**DP20N** T18C-00011/10001-up  
**DP25N** T18C-50001/60001-up  
**DP30N** T14E-30011/40001-up  
**DP35AN** T14E-50001/60001-up

## FOREWORD

This service manual is a guide for servicing Cat<sup>®</sup> Lift Trucks. For your convenience the instructions are grouped by systems as a ready reference.

The long productive life of your lift truck(s) depends on regular and proper servicing. Servicing consistent with what you will learn by reading this service manual. Read the respective sections of this manual carefully and familiarize yourself with all of the components before attempting to start a test, repair or rebuild job.

The descriptions, illustrations and specifications contained in this manual are for trucks with serial numbers in effect at the time of printing. Cat Lift Trucks reserve the right to change specifications or design without notice and without incurring obligation.

The trucks listed in this manual are powered by K15/K21/K25 gasoline engines or S4Q2/S4S diesel engines. For engine servicing, please refer to the applicable engine service manual.

### Safety Related Signs

The following safety related signs are used in this service manual to emphasize important and critical instructions:



Indicates a potentially hazardous situation which, if not avoided, could result in death or serious injury.



Indicates a potentially hazardous situation which, if not avoided, may result in death or serious injury or damage to the machine.



Indicates a condition that can cause damage to, or shorten service life of, the machine.

## **SAFETY**

 **WARNING**

The proper and safe lubrication and maintenance for these lift trucks, recommended by Cat Lift Trucks, are outlined in the **OPERATION & MAINTENANCE MANUAL**.

Improper performance of lubrication or maintenance procedures is dangerous and could result in injury or death. Read and understand the **OPERATION & MAINTENANCE MANUAL** before performing any lubrication or maintenance on these trucks.

The serviceman or mechanic may be unfamiliar with many of the systems on this truck. This makes it important to use caution when performing service work. A knowledge of the system and/or components is important before the removal or disassembly of any component.

Because of the size of some of the truck components, the serviceman or mechanic should check the weights noted in this Manual. Use proper lifting procedures when removing any components.

Following is a list of basic precautions that should always be observed.

1. Read and understand all warning plates and decals on the truck before operating, lubricating or repairing the product.
2. Always wear protective glasses and protective shoes when working around trucks. In particular, wear protective glasses when pounding on any part of the truck or its attachments with a hammer or sledge. Use welders gloves, hood/goggles, apron and other protective clothing appropriate to the welding job being performed. Do not wear loose-fitting or torn clothing. Remove all rings from fingers when working on machinery.
3. Do not work on any truck that is supported only by lift jacks or a hoist. Always use blocks or jack stands to support the truck before performing any disassembly.

 **WARNING**

Do not operate these trucks unless you have read and understood the instructions in the **OPERATION & MAINTENANCE MANUAL**. Improper truck operation is dangerous and could result in injury or death.

4. Lower the forks or other implements to the ground before performing any work on the truck. If this cannot be done, make sure the forks or other implements are blocked correctly to prevent them from dropping unexpectedly.
5. Use steps and grab handles (if applicable) when mounting or dismounting a truck. Clean any mud or debris from steps, walkways or work platforms before using. Always face truck when using steps, ladders and walkways. When it is not possible to use the designed access system, provide ladders, scaffolds, or work platforms to perform safe repair operations.
6. To avoid back injury, use a hoist when lifting components which weigh 23 kg (50 lb.) or more. Make sure all chains, hooks, slings, etc., are in good condition and are of the correct capacity. Be sure hooks are positioned correctly. Lifting eyes are not to be side loaded during a lifting operation.
7. To avoid burns, be alert for hot parts on trucks which have just been stopped and hot fluids in lines, tubes and compartments.
8. Be careful when removing cover plates. Gradually back off the last two bolts or nuts located at opposite ends of the cover or device and pry cover loose to relieve any spring or other pressure, before removing the last two bolts or nuts completely.
9. Be careful when removing filler caps, breathers and plugs on the truck. Hold a rag over the cap or plug to prevent being sprayed or splashed by liquids under pressure. The danger is even greater if the truck has just been stopped because fluids can be hot.

10. Always use tools that are in good condition and be sure you understand how to use them before performing any service work.
11. Reinstall all fasteners with same part number. Do not use a lesser quality fastener if replacements are necessary.
12. If possible, make all repairs with the truck parked on a level, hard surface. Block truck so it does not roll while working on or under truck.
13. Disconnect battery and discharge any capacitors (electric trucks) before starting to work on truck. Hang "Do not Operate" tag in the Operator's Compartment.
14. Repairs, which require welding, should be performed only with the benefit of the appropriate reference information and by personnel adequately trained and knowledgeable in welding procedures. Determine type of metal being welded and select correct welding procedure and electrodes, rods or wire to provide a weld metal strength equivalent at least to that of parent metal.
15. Do not damage wiring during removal operations. Reinstall the wiring so it is not damaged nor will it be damaged in operation by contacting sharp corners, or by rubbing against some object or hot surface. Place wiring away from oil pipe.
16. Be sure all protective devices including guards and shields are properly installed and functioning correctly before starting a repair. If a guard or shield must be removed to perform the repair work, use extra caution.
17. Always support the mast and carriage to keep carriage or attachments raised when maintenance or repair work is performed, which requires the mast in the raised position.
18. Loose or damaged fuel, lubricant and hydraulic lines, tubes and hoses can cause fires. Do not bend or strike high pressure lines or install ones which have been bent or damaged. Inspect lines, tubes and hoses carefully. Do not check for leaks with your hands. Pin hole (very small) leaks can result in a high velocity oil stream that will be invisible close to the hose. This oil can penetrate the skin and cause personal injury. Use cardboard or paper to locate pin hole leaks.
19. Tighten connections to the correct torque. Make sure that all heat shields, clamps and guards are installed correctly to avoid excessive heat, vibration or rubbing against other parts during operation. Shields that protect against oil spray onto hot exhaust components in event of a line, tube or seal failure, must be installed correctly.
20. Relieve all pressure in air, oil or water systems before any lines, fittings or related items are disconnected or removed. Always make sure all raised components are blocked correctly and be alert for possible pressure when disconnecting any device from a system that utilizes pressure.
21. Do not operate a truck if any rotating part is damaged or contacts any other part during operation. Any high speed rotating component that has been damaged or altered should be checked for balance before reusing.

## HOW TO USE THIS MANUAL

Truck models covered in this manual:

- MC Truck (Mechanical Control System)  
Mechanically controlled hydraulic system (conventional lever system)
- FC Truck (Finger-tip Control System)  
Electronically controlled hydraulic system

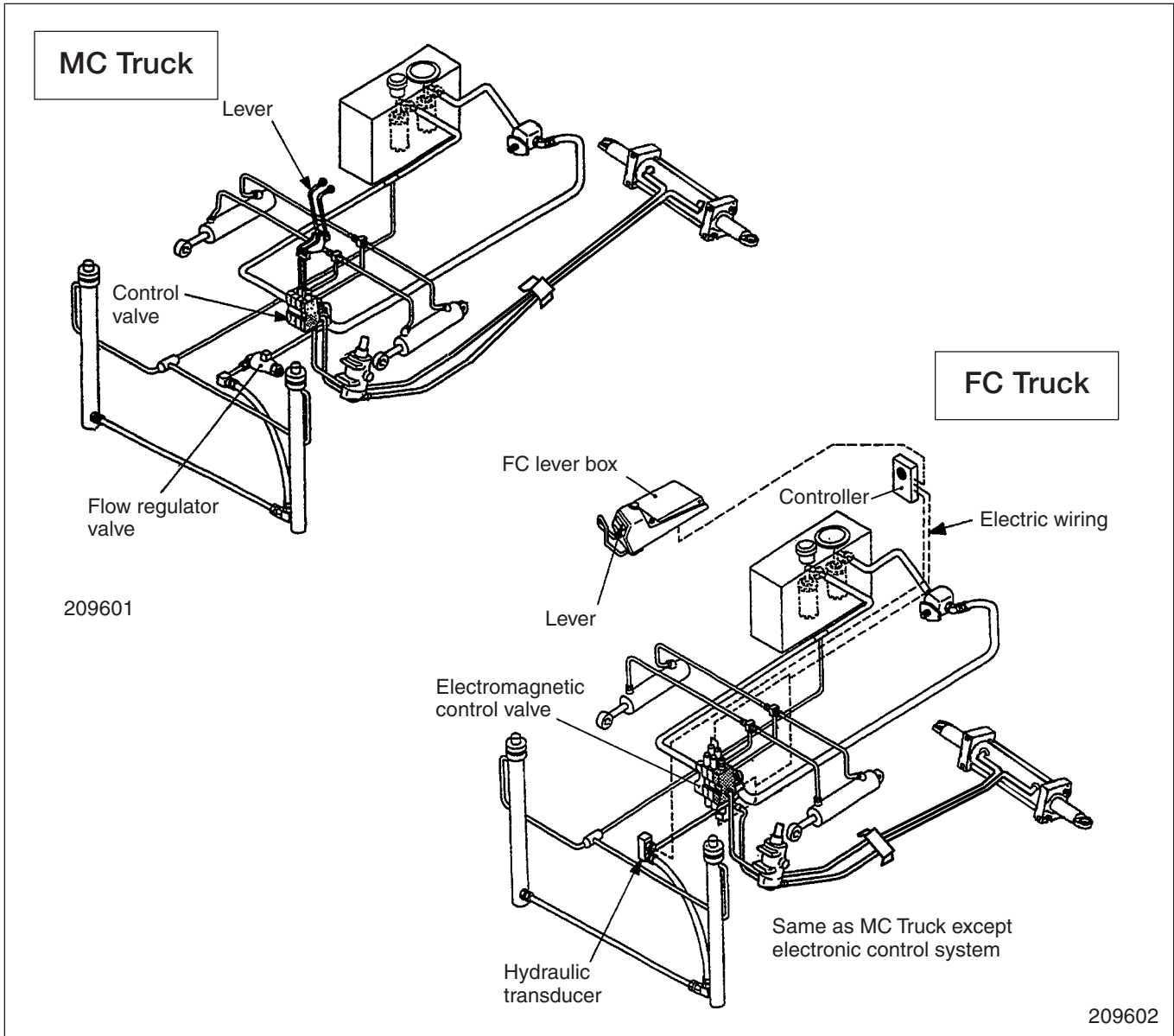

- Gasoline Engine Truck (GPE, GP) . . . . . Equipped with K15/K21 or K25 Gasoline Engine
- Diesel Engine Truck (DP) . . . . . Equipped with S4Q2 or S4S Diesel Engine
- Powershift Truck . . . . . Equipped with Powershift Transmission
- Manual Truck . . . . . Equipped with Manual Transmission  
(2 Types of Clutch; Dry and Wet)

# HOW TO USE THIS MANUAL (continued) (Removal, Installation, Assembly and Disassembly)

Disassembly diagram (example)

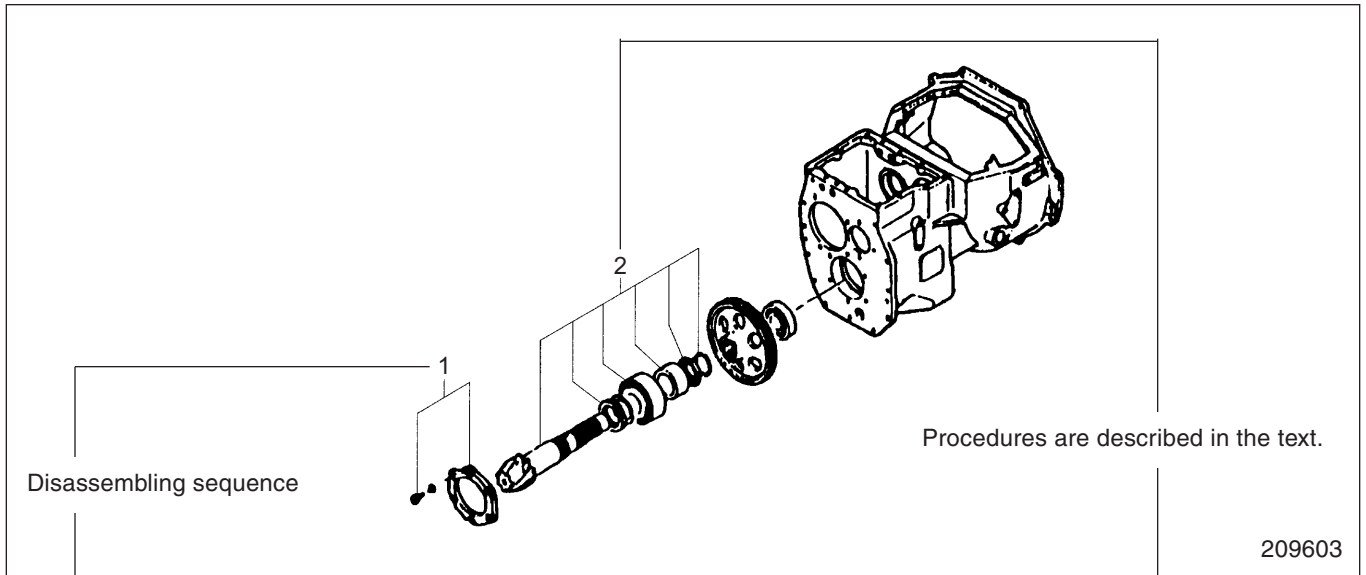

### Sequence

- 1 Cover, Bolt, Washer (part name)
- 2 Snap ring ..... (part name)

### Suggestion for disassembling

1. Output shaft, Removing  
Remove output shaft using a special tool.

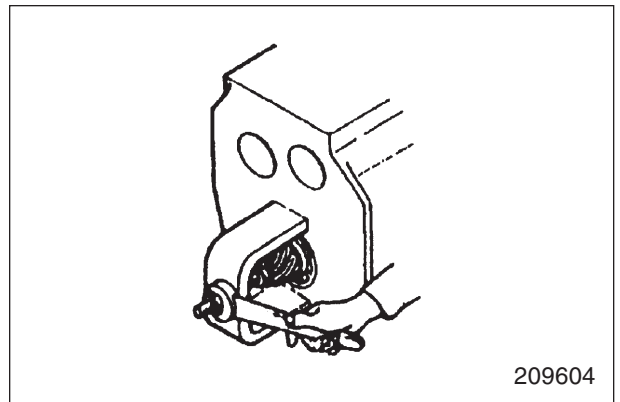

### Service Data

Gear Backlash	A	0.11 to 0.28 mm (0.0043 to 0.0110 in.)
	B	0.5 mm (0.020 in.)

A: Standard Value

B: Repair or Service Limit

## Symbols or abbreviation

OP	Option
R1/4	Taper pipe thread (external) 1/4 inch (formerly PT1/4)
Rc1/8	Taper pipe thread (internal) 1/8 inch (formerly PT1/8)
G1/4A	Straight pipe thread (external) 1/4 inch (formerly PF1/4-A)
Rp1/8	Straight pipe thread (internal) 1/8 inch (formerly PS1/8)

## Units

1. SI Units are used in this manual.
2. The following table shows the conversion of SI unit and customary unit.

Item	SI unit	Customary unit
Force	1 N	0.1020 kgf
	1 lbf	0.4536 kgf
Pressure	1 kPa	0.0102 kgf/cm <sup>2</sup>
	1 psi	0.0703 kgf/cm <sup>2</sup>
Torque	1 N·m	0.1020 kgf·m
	1 lbf·ft	0.1383 kgf·m

# GROUP INDEX

GROUP INDEX	Items	
GENERAL INFORMATION	Model view, Truck models covered, Serial number locations, Dimensions, Technical data	<b>1</b>
COOLING SYSTEM	Specification, Structure, Removal and installation, Inspection and adjustment	<b>2</b>
ELECTRICAL SYSTEM	Chassis electrical devices wiring outline, Structure, Console box, Battery maintenance, Wire color, Troubleshooting, Electrical schematics	<b>3</b>
CONTROLLERS	Outline, Main functions, Service tool functions, Locations of sensors and switches	<b>4</b>
POWER TRAIN	Removal and installation (MC models), Removal and installation (FC models)	<b>5</b>
CLUTCHES	Advantages and disadvantages of clutches by type of drive system, Principal differences between dry-type and wet-type clutches, Structure and function of clutch, Adjustment, Troubleshooting, Service data	<b>6</b>
MANUAL TRANSMISSION	Structures, Removal and installation, Disassembly, Inspection and repair, Reassembly, Troubleshooting, Service data	<b>7</b>
POWERSHIFT TRANSMISSION	Structure and function, Removal and installation, Disassembly and reassembly, Inspection and adjustment, Troubleshooting, Service data	<b>8</b>
FRONT AXLE AND REDUCTION DIFFERENTIAL	Structure, Removal and installation, Disassembly and reassembly, Troubleshooting, Service data	<b>9</b>
REAR AXLE	Structure and functions, Removal and installation, Disassembly and reassembly	<b>10</b>
BRAKE SYSTEM	Structure, Disassembly and reassembly, Inspection and adjustment, Troubleshooting, Service data	<b>11</b>
STEERING SYSTEM	Structure and function, Disassembly and reassembly, Steering valve, Troubleshooting, Service data	<b>12</b>
HYDRAULIC SYSTEM	Structure and functions, Disassembly and reassembly, Inspection and adjustment, Troubleshooting, Service data, MC control valve, FC control valve	<b>13</b>
MAST AND FORKS	Mast system, Structure and function, Removal and installation, Disassembly and reassembly, Removal and installation of mast rollers and strips without removing mast from truck, Inspection and adjustment, Troubleshooting, Service data	<b>14</b>
SERVICE DATA	Maintenance schedule, Tightening torque for standard bolts and nuts, Periodic replacement parts, Lubrication instructions, Special service tools	<b>15</b>



# GENERAL INFORMATION

Model View .....	1 – 1
Truck Models Covered .....	1 – 2
Serial Number Locations .....	1 – 4
Dimensions .....	1 – 5
Technical Data .....	1 – 6

**Model View**

MC Truck

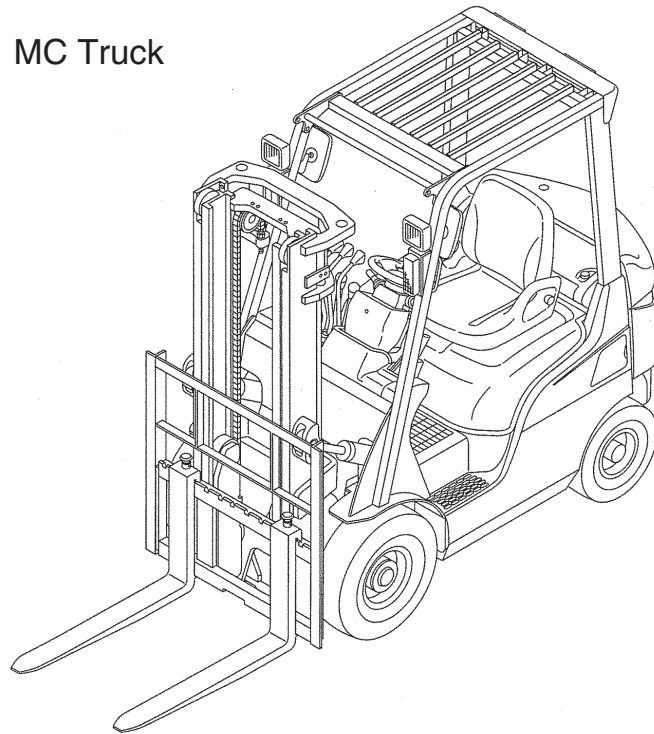

209605

FC Truck

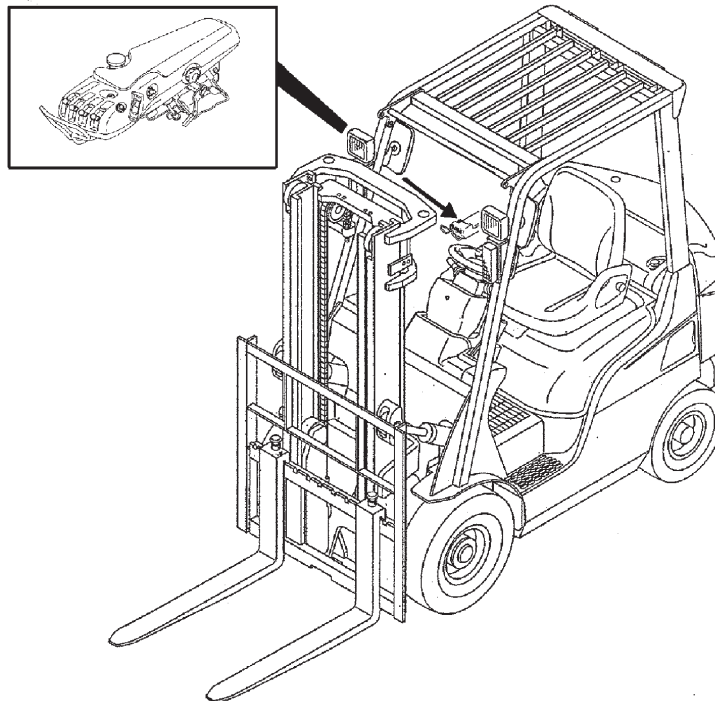

210780

## Truck Models Covered

This Service Manual provides servicing and maintenance information for the following trucks:

Engine control	Gasoline engine	Diesel engine	LPG engine
Standard (Non-electronic control)	MC/—	MC/FC	—
Electronic control	MC/FC	—	MC/FC

(FC type is used in torque converter model only.)

Truck class	Standard gasoline engine models			Diesel engine models		
	Truck model	Model code - serial number	Engine mounted	Truck model	Model code - serial number	Engine mounted
1 ton class	GP15N —	T25C-50001~ —	K15 —	DP15N DP15N(F)	T16D-50001~ T16D-60001~	S4Q2 S4Q2
	GP18N	T25C-70001~	K15	DP18N	T16D-70001~	S4Q2
	GP15ZN	T34-50011~	K21	DP18N(F)	T16D-80001~	S4Q2
	GP18ZN	T34-70001~	K21	DP20CN	T16D-85001~	S4Q2
	GP20CN	T34-20001~	K21	DP20CN(F)	T16D-87001~	S4Q2
2 ton class	GP20N	T17D-00011~	K21	DP20N	T18C-00011~	S4S
	GP25N	T17D-50001~	K21	DP20N(F)	T18C-10001~	S4S
	GP20ZN	T35-00011~	K25	DP25N	T18C-50001~	S4S
	GP25ZN	T35-50001~	K25	DP25N(F)	T18C-60001~	S4S
3 ton class	GP30N —	T13F-30011~ —	K25 —	DP30N DP30N(F)	T14E-30011~ T14E-40001~	S4S S4S
	GP35AN	T13F-50001~	K25	DP35AN	T14E-50001~	S4S
	—	—	—	DP35AN(F)	T14E-60001~	S4S
	—	—	—	—	—	—

Notice: Characters at the end of truck model should be read as follows:

(F) : Finger-tip-controlled model

None: Mechanically-controlled model

Z : High-power engine model

C : Short body model

Truck class	Electronically-controlled gasoline engine models			Electronically-controlled LPG engine models		
	Truck model	Model code - serial number	Engine mounted	Truck model	Model code - serial number	Engine mounted
1 ton class	GPE15N	T25C-58001~	K15	—	—	—
	GPE15N(F)	T25C-68001~	K15			
	GPE18N	T25C-78001~	K15			
	GPE18N(F)	T25C-88001~	K15			
	GPE15ZN	T34-58011~	K21			
	GPE15ZN(F)	T34-68001~	K21			
	GPE18ZN	T34-78001~	K21			
	GPE18ZN(F)	T34-88001~	K21			
	GPE20CN	T34-28001~	K21			
	GPE20CN(F)	T34-38001~	K21			
2 ton class	GPE20N	T17D-08011~	K21	—	—	—
	GPE20N(F)	T17D-18001~	K21			
	GPE25N	T17D-58001~	K21			
	GPE25N(F)	T17D-68001~	K21			
	GPE20ZN	T35-08011~	K25			
	GPE20ZN(F)	T35-18001~	K25			
	GPE25ZN	T35-58001~	K25			
	GPE25ZN(F)	T35-68001~	K25			
3 ton class	GPE30N	T13F-38011~	K25	— GPE30N(F)	— T13F-49001~	— K25
	GPE30N(F)	T13F-48001~	K25			
	GPE35AN	T13F-58001~	K25			
	GPE35AN(F)	T13F-68001~	K25			

# Serial Number Locations

Name Plate

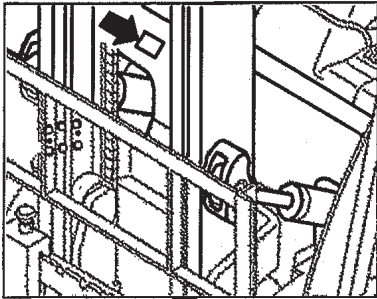

Chassis Serial Number

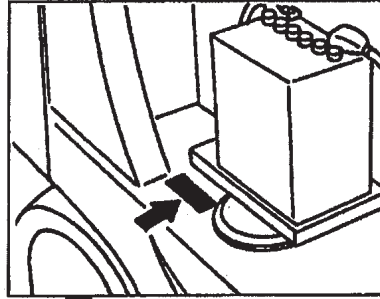

Gasoline Engine Serial Number

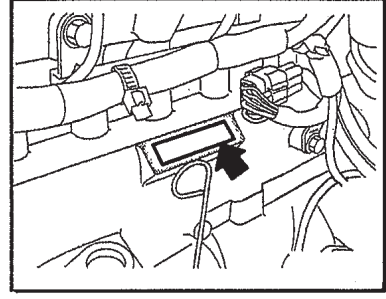

Diesel Engine Serial Number  
(2, 3 ton classes)

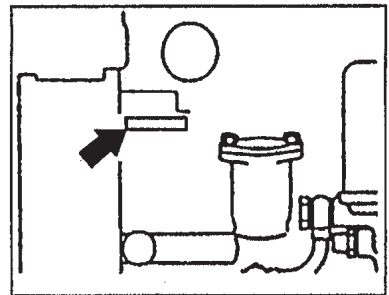
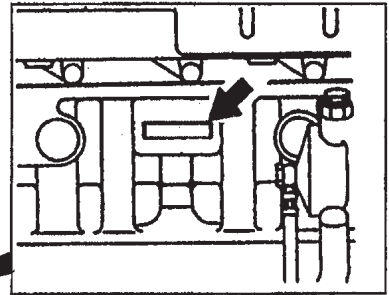

Diesel Engine Serial Number  
(1 ton class and DP20N-25N)

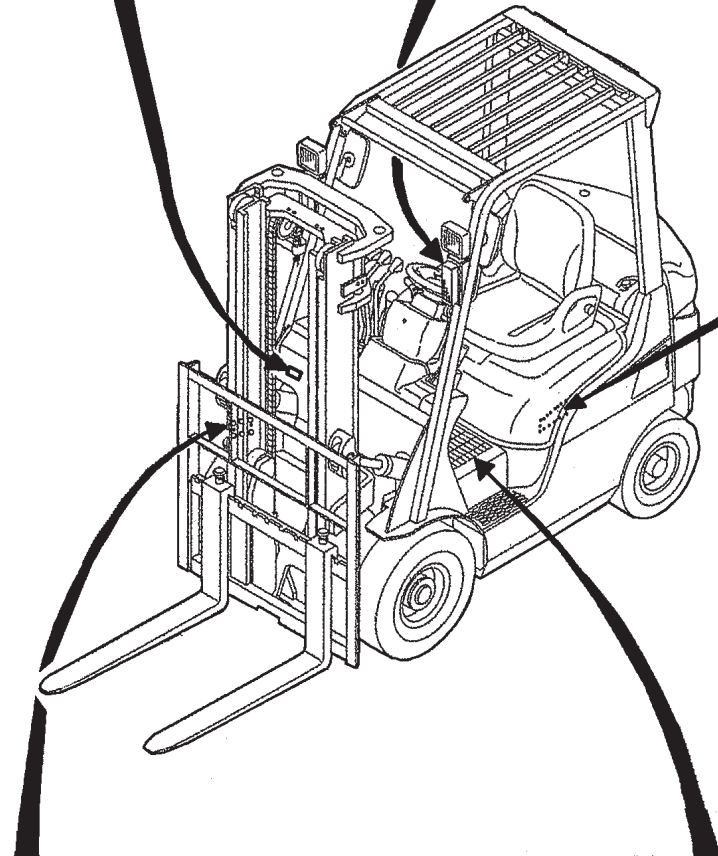

Mast Serial Number

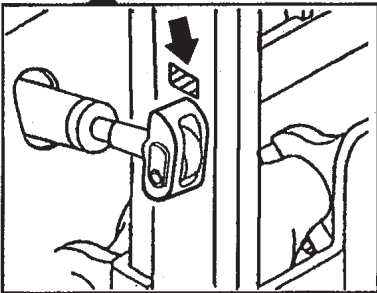

Transmission Serial Number  
(Manual Transmission Truck)

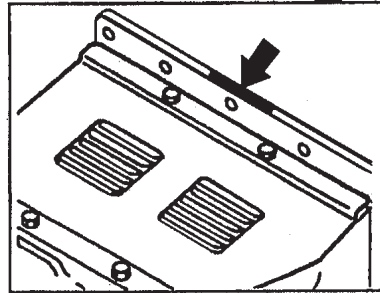

Transmission Serial Number  
(Powershift Transmission Truck)

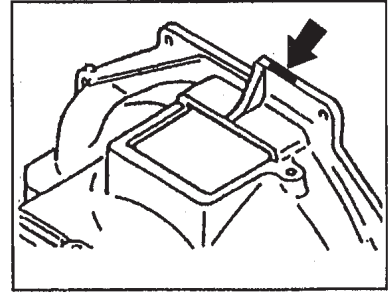

Dimensions

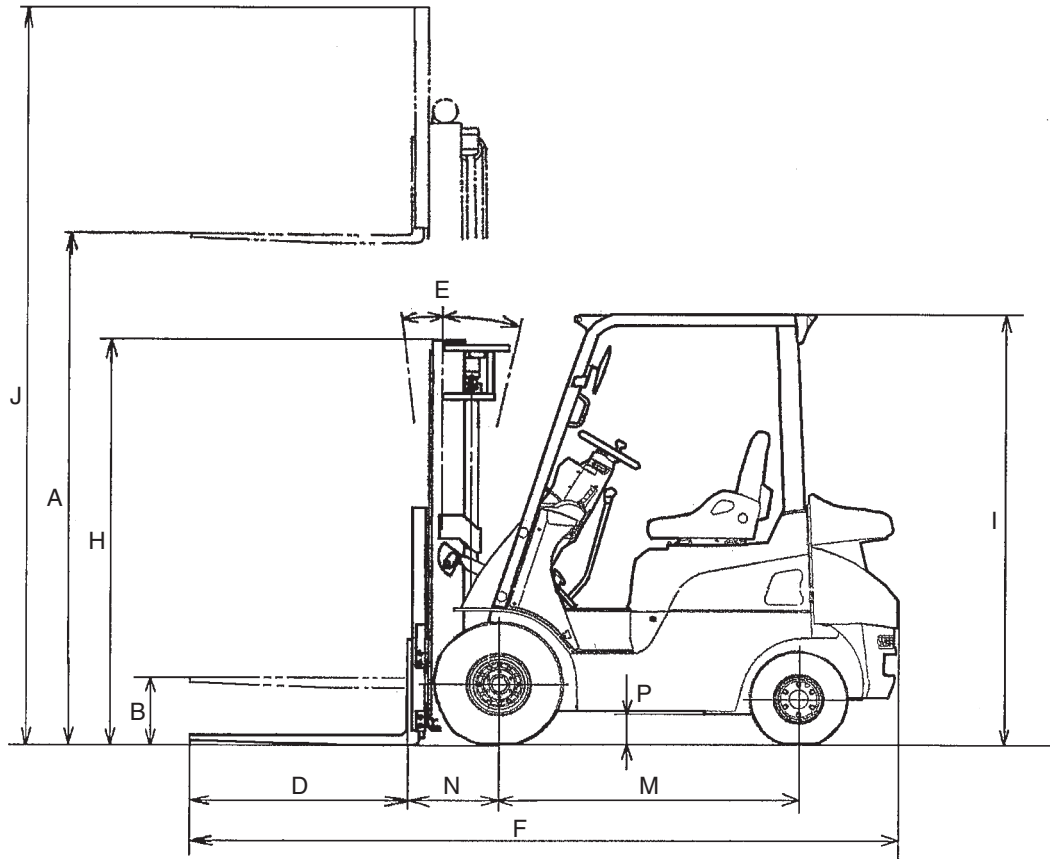
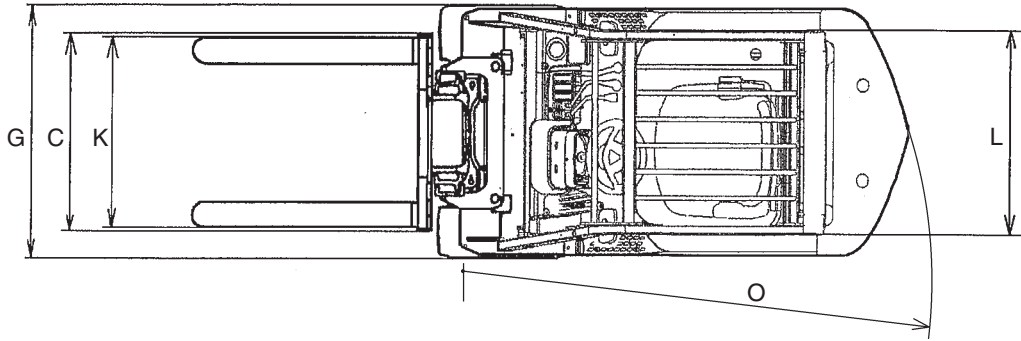

**Technical Data**

Unit: mm (in.)

Ref. No.	Model	Gasoline-engine Truck	GP15N GP15ZN GPE15N GPE15ZN	GP18N GP18ZN GPE18N GPE18ZN
		Diesel-engine Truck	(DP15N)	(DP18N)
Item				
A	Maximum lift	3000 (118)		
B	Free lift	115 (4.5)		
C	Fork spread (outside)	200 to 920 (7.9 to 36.2)		
D	Fork length	920 (36.2)		
E	Tilt angle (forward – backward)	6° – 12°		
F	Overall length	3180 (125.2)	3220 (126.8)	
G	Overall width (outside of tires)	Single tire	1065 (41.9)	
		Dual tire	1330 (52.4)	
H	Overall height (to top of mast lowered)	1995 (78.5)		
I	Overall height (to top of overhead guard)	2065 (81.3)		
J	Overall height (mast extended)	4055 (159.6)		
K	Tread (front)	Single tire	888.5 (35)	
		Dual tire	1025 (40.4)	
L	Tread (rear)	900 (35.4)		
M	Wheelbase	1400 (55.1)		
N	Front overhang	400 (15.7)		
O	Minimum turning radius	1950 (76.8)	1980 (78)	
P	Underclearance (at frame)	150 (5.9)		

Unit: mm (in.)

GP20CN GPE20CN	GP20N GP20ZN GPE20N GPE20ZN	GP25N GP25ZN GPE25N GPE25ZN	GP30N GPE30N	GP35AN GPE35AN
(DP20CN)	(DP20N)	(DP25N)	(DP30N)	(DP35AN)
3000 (118)			3030 (119)	3000 (118)
115 (4.5)	140 (5.5)	145 (5.7)	150 (5.9)	
220 to 920 (8.7 to 36.2)	220 to 1000 (8.7 to 39.4)		250 to 1000 (9.8 to 39.4)	
920 (36.2)		1070 (42.1)		
6° – 12°				
3280 (129.1)	3410 (134.3)	3625 (142.7)	3795 (149.4)	3860 (152)
1065 (41.9)	1150 (45.3)		1275 (50.2)	1290 (50.8)
—	1480 (58.3)		1490 (58.7)	
1995 (78.5)			2045 (80.5)	2180 (85.8)
2065 (81.3)	2070 (81.5)		2095 (82.5)	2105 (82.9)
4055 (159.6)			4085 (160.8)	4055 (159.6)
890 (35)	960 (37.8)		1060 (41.7)	
—	1140 (44.9)			
900 (35.4)	980 (38.6)			
1400 (55.1)	1600 (63)		1700 (66.9)	
415 (16.3)	455 (17.9)		490 (19.3)	
2020 (79.5)	2200 (86.6)	2230 (87.8)	2380 (93.7)	2440 (96.1)
150 (5.9)	160 (6.3)		190 (7.5)	200 (7.9)



GENERAL INFORMATION

Unit: mm (in.)

Item		Model	Gasoline-engine Truck	GP15N GP15ZN GPE15N GPE15ZN	GP18N GP18ZN GPE18N GPE18ZN
			Diesel-engine Truck	(DP15N)	(DP18N)
Performance	Capacity/load center		kgf/mm (lbf/in.)	1500/500 (3310/20)	1750/500 (3860/20)
	Lift speed	rate load	mm/sec (fpm)	GP15N: 500 (98) GP15ZN: 570 (112) GPE15N: 560 (110) GPE15ZN: 640 (126) DP15N: 600 (118)	GP18N: 500 (98) GP18ZN: 570 (112) GPE18N: 560 (110) GPE18ZN: 640 (126) DP18N: 600 (118)
		unload	mm/sec (fpm)	GP15N: 560 (110) GP15ZN: 640 (126) GPE15N: 570 (112) GPE15ZN: 650 (128) DP15N: 650 (128)	GP18N: 560 (110) GP18ZN: 640 (126) GPE18N: 570 (112) GPE18ZN: 650 (128) DP18N: 650 (128)
	Travel speed	rate load	km/h (mph)	19/(11.8)	
		unload	km/h (mph)	19.5/(12.1)	

Thank you so much for reading.  
Please click the “Buy Now!”  
button below to download the  
complete manual.



After you pay.

You can download the most  
perfect and complete manual in  
the world immediately.

Our support email:

[ebooklibonline@outlook.com](mailto:ebooklibonline@outlook.com)