



Service Repair Manual

Models

307B Mini Hydraulic
Excavator

Product: MINI HYD EXCAVATOR

Model: 307B MINI HYD EXCAVATOR 6KZ

Configuration: 307B TRACK-TYPE EXCAVATOR /SWING BOOM ARRANGEME/ 6KZ00001-UP (MACHINE) POWERED BY 4M40 ENGINE

Disassembly and Assembly 307B Excavator Machine Systems

Media Number -REN1091-03

Publication Date -01/09/2000

Date Updated -23/07/2018

i01706756

Support (Swing Boom) - Remove

SMCS - 7051-S4

S/N - 6KZ1-UP

S/N - 7DZ1-UP

S/N - AFB1-UP

Removal Procedure

Table 1

Required Tools			
Tool	Part Number	Part Description	Qty
A		Adjustable Work Bench	1
	8T-5255	Portable Hydraulic Jack	1

Start By:

- Remove the boom. Refer to Disassembly and Assembly, "Swing Boom - Remove".
 - Remove the boom cylinder. Refer to Disassembly and Assembly, "Boom Cylinder (Swing Boom) - Remove".
-

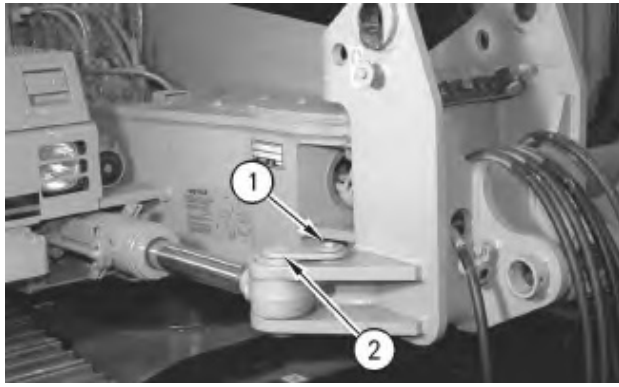

Illustration 1

g00533732

1. Remove bolt (1) and remove pin assembly (2).

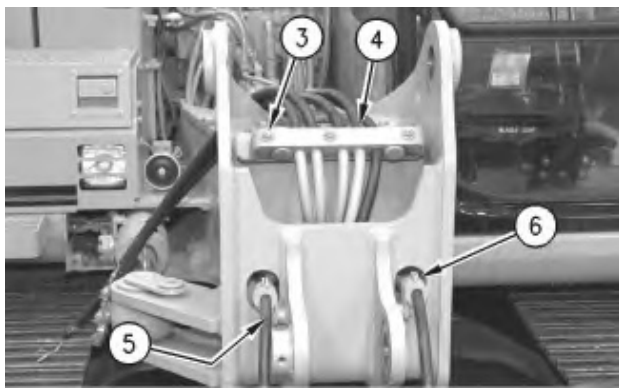

Illustration 2

g00533734

2. Remove nuts (3), clamp (4), and bolts (5). Remove two clamps (6).

Note: Carefully remove the hoses through the support while the support is being removed.

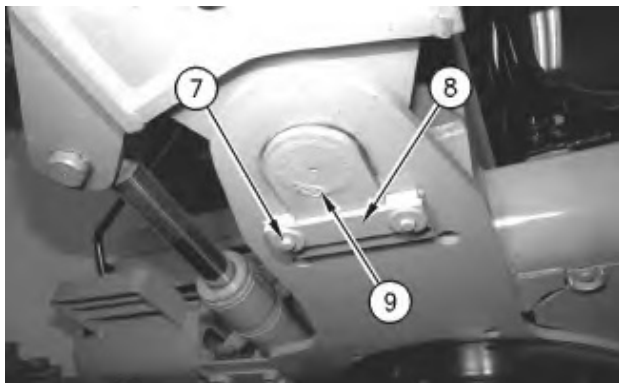

Illustration 3

g00533685

3. Remove bolts (7) and remove strap (8). Remove bottom pin assembly (9).

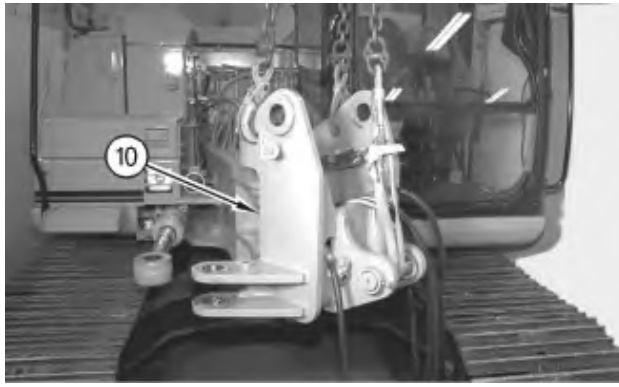

Illustration 4

g00533721

4. Attach a suitable lifting device to support assembly (10).

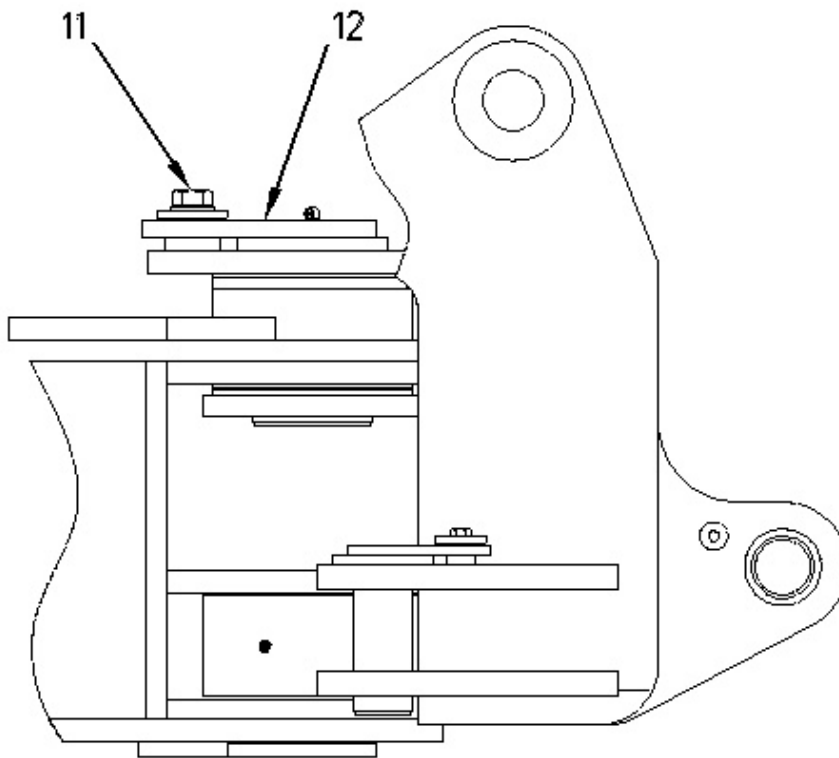

Illustration 5

g00533963

5. Remove retaining bolt (11) and the washer from pin assembly (12).

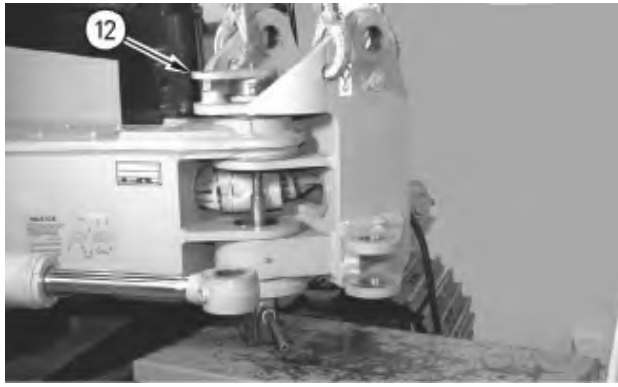

Illustration 6

g00533726

6. Use Tooling (A) and remove top pin assembly (12).

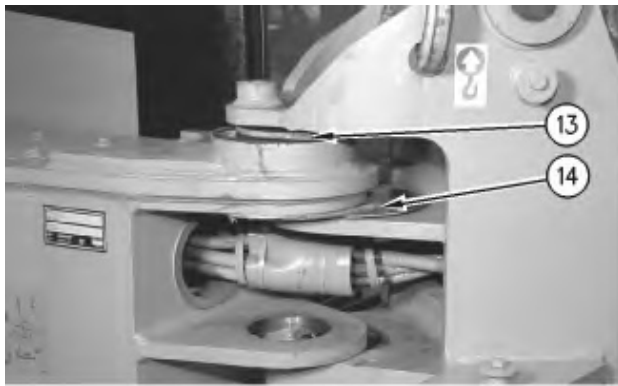

Illustration 7

g00533928

7. Remove spacer (13) and remove shims (14). Remove the support assembly. The weight of the support assembly is approximately 225 kg (500 lb).

Thank you so much for reading.
Please click the “Buy Now!”
button below to download the
complete manual.



After you pay.

You can download the most
perfect and complete manual in
the world immediately.

Our support email:

ebooklibonline@outlook.com