

Document Title: Checking function, engine	Function Group: 210	Information Type: Service Information	Date: 2014/5/26
Profile:			

Checking function, engine

Op nbr

1. First check:

- Fluid levels
- Warning lamps
- Instruments
- Battery voltag
- Fuses (correct rating)

2. Separate systems:

- If two or more systems, and/or circuits work together.
CHECK THE SYSTEMS/CIRCUITS INDIVIDUALLY.

3. If the machine has poor pulling power, the fault may be in the engine or the transmission; Then check the stalling speed, see specifications.

- If the engine stalling speed is within the prescribed values the fault can be found in the transmission.
- If the engine stalling speed is low, then check according to point 4.

4. Checking engine

- Checking oil and coolant respectively, discolouration, smell, etc.
- Checking exhaust pipe (sticky inside).
- Checking air filter and turbocharger.
- Does the engine run unevenly (imbalance-noise)
- Checking excess pressure in header tank.
- Crankcase ventilation (excess pressureclogged).
- Oil dipstick remove (excess pressure).
- Smoky exhaust (colourimpurities, smell).
- Bleed the fuel system.
- Slacken the delivery pipes [1] ⓘ one at a time with the engine running).
- Check rotational speed.
- Check feed pressure (before and after filter).
- Make compression test (if incorrect repeat using oil).
- Check injectors.
- Check injection timing.

[1]This check must not be done on low-emission engines (fuel under very high pressure).

Document Title: Engine, fitting	Function Group: 210	Information Type: Service Information	Date: 2014/5/26
Profile:			

Engine, fitting

Op nbr 21072

Lifting sling, 3m

Shackle 3/8"

Ratchet block, 750 kg (1654 lb)

1. Connect lifting device to the engine according to Fig.

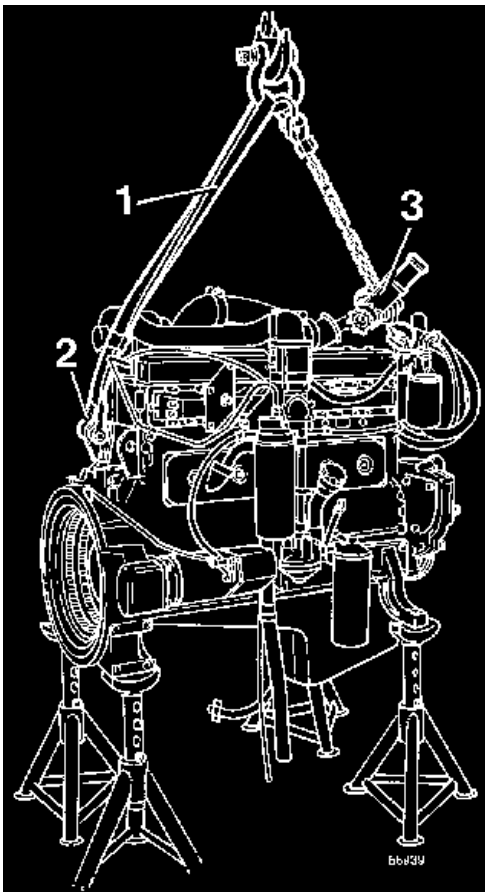

2.

Figure 1
Connecting lifting device

1. Lifting sling, 3m
2. Shackle 3/8"
3. Ratchet block, 750 kg (1654 lb)

3. Lifting in the engine in the machine

NOTE!

Make sure that the hoses for the air conditioning (if fitted) are not damaged!

4. Align the engine with the transmission and fit the bolts.
Remove any supports under the transmission.
5. Fit the bolts between engine mountings and rubber cushions.
6. Bolt on the transmission oil cooler in the bracket on the engine.
7. Fit fan belt pulley, hub, bracket and tensioning pulley, see Fig.

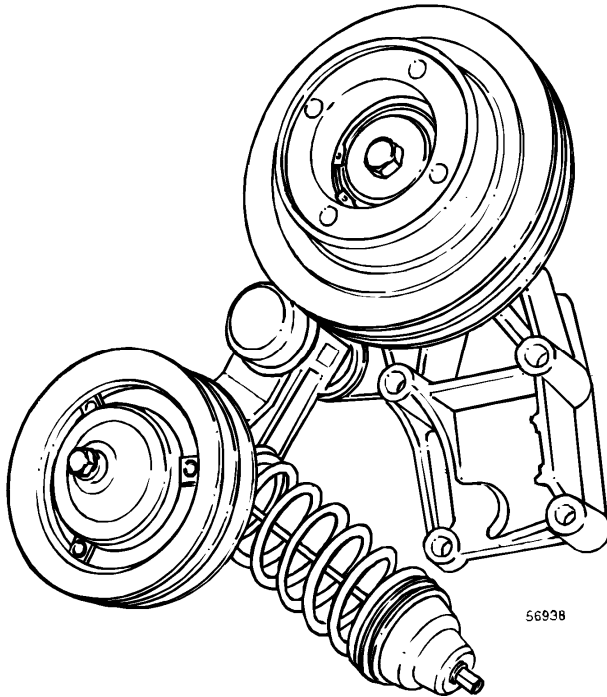

8.

Figure 2
Fan belt pulley complete with hub, bracket and tensioning pulley

9. Fit belt pulleys on the crankshaft.
10. Bolt on the compressor (if fitted) for the air conditioning and fit its drive belt and the fan belts.
11. Fit the stays between the engine and the air guide ring.
12. Fit the fan
13. Fit the coolant pipe between the coolant pump and the transmission oil cooler, using a new O-ring.
Connect the hoses for the header tank, the coolant filter (if fitted) and the cab heater to the pipe.
14. Bolt on the fuel system water trap in the bracket on the frame. Connect the fuel lines to the feed pump and the injection pump.
15. Connect the cable harness to B+ on the alternator, connector BB to the stop solenoid and SE1 to the temperature sensor. Clamp the cable harness using the screw clamps.
16. Connect the governor control rod to the injection pump.
17. Bolt on the preheating coil relay bracket and the bracket for the air conditioning drier filter (if fitted) to the bracket on the engine induction manifold. Connect the lead to preheating coil.
18. Connect the earth lead to the starter motor (black terminal).
Connect the red lead of the cable harnesses to the starter motor (red terminal).
19. Connect leads to oil pressure sensor and to dust indicator, clamp using the screw clamps.

20. Fit the upper radiator hose.
21. Fit the breather filter and bolt on the pump (if fitted) for the secondary steering.
22. Lift the hood unit into position, see Fig.

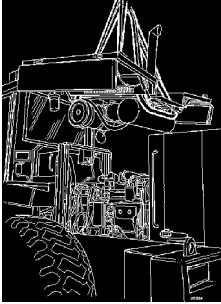

23.

Figure 3
Fitting hood unit

24. Connect as follows:
 - The exhaust pipe to the silencer.
 - The hoses to the header tank, 3 pcs.
 - The hose to the hydraulic tank breather filter.
 - The induction hose to the turbocharger.
 - The hose to the dust indicator.
25. Fit the hood plates on both sides of the hydraulic tank and the cover door at the top.
26. Fill with coolant and engine oil.
27. Remove the steering joint lock, start the engine and check that there are no leaks.

Document Title: Engine, removing	Function Group: 210	Information Type: Service Information	Date: 2014/5/26
Profile:			

Engine, removing

Op nbr 21070

Lifting sling, 3m

Shackle 3/8"

Ratchet block, 750 kg (1654 lb)

1. Secure the steering frame joint with the steering frame joint lock.
2. Turn off the current with the battery disconnect switch.
3. Open the cover to the header tank and drain the coolant.
Drain the engine oil.

WARNING

There is a danger of scalding, when removing the header tank cap (radiator cap), as the cooling system is pressurised when hot.

4. Remove the cover door above and the hood plates on both sides of the hydraulic tank.
5. Disconnect as follows:
 - The exhaust pipe from the silencer.
 - Hoses from header tank, 3 pcs.
 - Hose from hydraulic tank breather filter.
 - Induction hose from the turbocharger.
 - Hose from the dust indicator.
6. Lift away the hood plate above the engine and the side covers as one unit together with silencer, air cleaner and header tank see Fig.

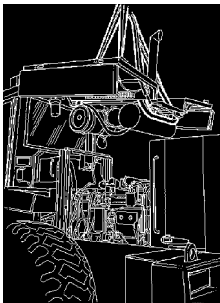

7.

Figure 1
Removing hood plate

8. Open the side covers on both sides of the hydraulic tank and remove the lower cover plates.
9. Disconnect the governor control rod from the injection pump.

10. Disconnect necessary leads and remove clamps from:
 - starter motor
 - preheating coil
 - alternator
 - temperature sensor
 - oil pressure sensor and stop solenoid
11. Remove the preheating relay bracket and the bracket for air conditioning drier filter (if fitted) from the bracket by the engine induction manifold. Place the drier filter on the frame without disconnecting the hoses.

⚠ WARNING

Do not disconnect hoses for the air conditioning (AC) (if fitted), otherwise the refrigerant will escape from the system.

12. Loosen the bracket for the engine oil and the coolant draining hoses. Disconnect fuel lines from injection pump and feed pump. Loosen the water trap and put it on the frame
13. Swing out the radiator and condenser (if fitted), remove the fan and the fan hub. Remove the attaching stays, 3 pcs, for the air guide ring. Remove the fan belts and the belt pulley. Also remove the belt pulley for the air conditioning compressor (if fitted)
14. Remove fan belt pulley complete with hub, bracket and tensioning pulley, see Fig.

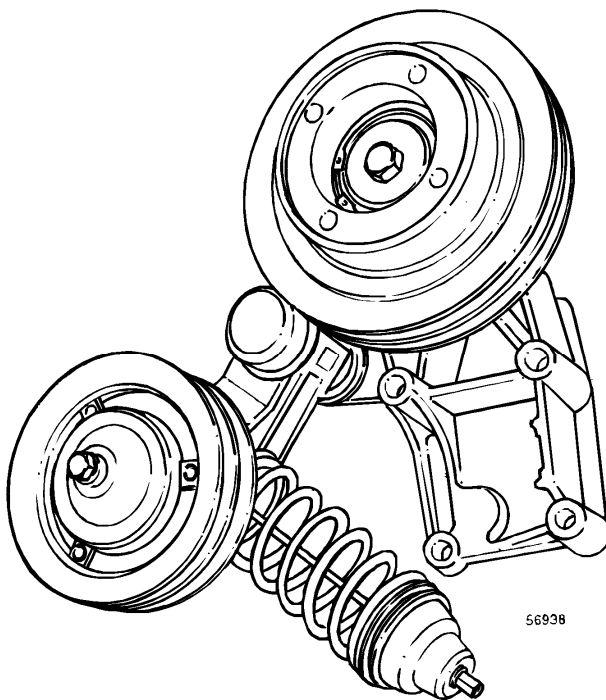

15.

Figure 2
Fan belt pulley complete with hub, bracket and tensioning pulley

16. Remove the breather filter and loosen the secondary steering pump, (if fitted)
17. Free the electrical lead for the air filter dust indicator from the tank
18. Connect a lifting device to the engine, see Fig.
Remove the bolts between engine mounting and rubber cushion.
Remove the bolts between the engine and the transmission.

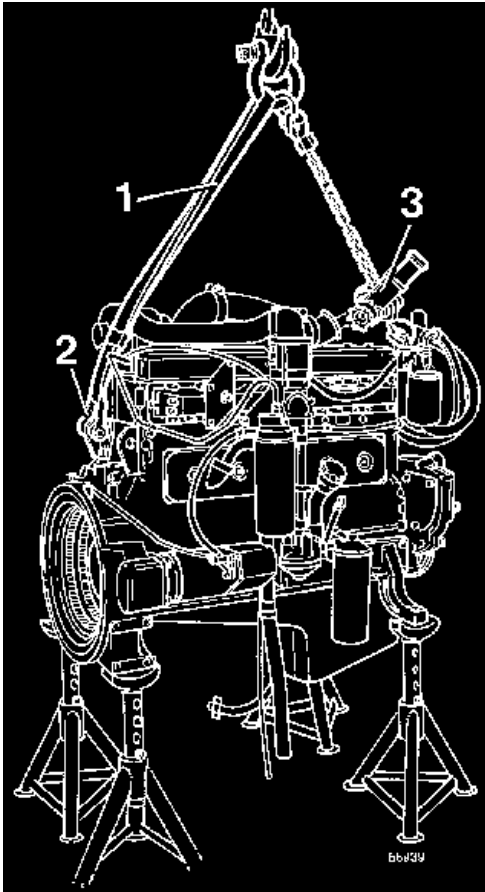

19.

Figure 3
Connecting lifting device

1. Lifting sling, 3m
2. Shackle 3/8"
3. Ratchet block, 750 kg (1654 lb)

20. Support the transmission against the front rear axle bracket, see Fig.

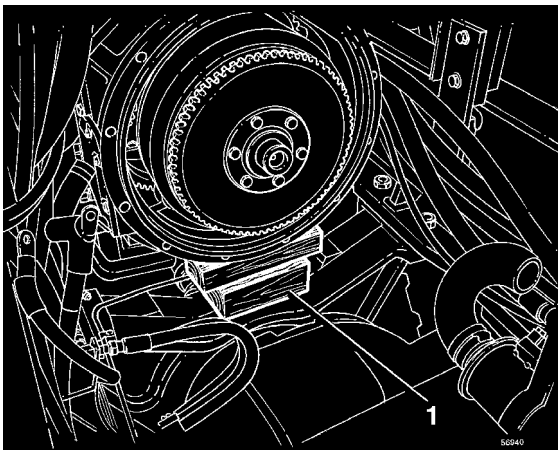

21.

Figure 4
Supporting transmission

1. Wooden blocks

22. Lift away the engine, see Fig.
Weight: approx. 750 kg (1654 lb)

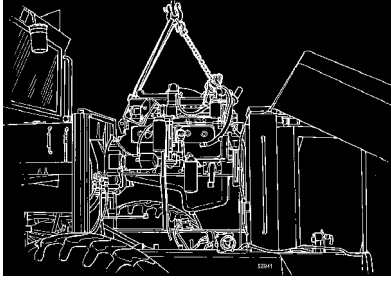

23.

Figure 5
Lifting out engine

Document Title: Specifications, L90B	Function Group: 210	Information Type: Service Information	Date: 2014/5/26
Profile:			

Specifications, L90B

Where tolerance limits have been given and unless otherwise stated, these apply to new parts and are not wear tolerances

Weights (approx.)

	kg	lb
Engine, standard	660	1455

Capacities

	litres	US gal
Engine incl. filter	17	4.5
Engine, when changing oil incl. filter	16	4.2

Unless otherwise stated the data are the same for all three versions of the engine, i.e. basic version, low emission version and high-altitude version.

General

Designation, basic version	TD61G, engine no. 497993
Designation, low emission version	TD61KBE, engine no. 497994
Flywheel output at 36.7 r/s (2200 rpm) Basic version and high-altitude version	109 kW (148 hp) SAE J 1349 Nett 109 kW (148 hp) DIN 70020
Flywheel output at 36.7 r/s (2200 rpm) Low emission version	113 kW (154 hp) SAE J 1349 Nett 113 kW (154 hp) DIN 70020
Output, gross at 36.7 r/s (2200 rpm) Basic version and high-altitude version	115 kW (156 hp) SAE J 1349 Gross
Output, gross at 36.7 r/s (2200 rpm) Low emission version	119 kW (162 hp) SAE J 1349 Gross
Torque at 23.3 r/s (1400 rpm) Basic version and high-altitude version	630 N m (465 lbf ft) SAE J 1349 Nett 640 N m (472 lbf ft) SAE J 1349 Gross 630 N m (465 lbf ft) DIN 70020
Torque at 26.7 r/s (1600 rpm) Low emission version	660 N m (487 lbf ft) SAE J 1349 Nett 670 N m (494 lbf ft) SAE J 1349 Gross 660 N m (487 lbf ft) DIN 70020
Number of cylinders	6
Cylinder bore	98.43 mm (3.875 in)
Stroke	120 mm (4.724 in)
Cylinder capacity, total	5.48 litres
Compression ratio	16:1
Compression pressure at starter motor revolutions, 3.3 r/s (200 rpm)	2.4 MPa (24 bar) (348 psi)
Order of injection	1-5-3-6-2-4
Idling speed, low	11.2 ± 0.5 r/s (670 ± 30 rpm) (435 ± 30 Hz)
Idling speed, high	39.7 ± 1.0 r/s (2380 ± 60 rpm)(1546 ± 60 Hz)
Stalling speed, torque converter	35 ± 1.25 r/s (2100 ± 75 rpm) (1365 ± 75 Hz)

Stalling speed, torque converter
+ working hydraulics

26.5 ± 1.7 r/s (1600 ± 100 rpm)(1040 ± 75 Hz)

Document Title: Specifications	Function Group: 214	Information Type: Service Information	Date: 2014/5/26
Profile:			

Specifications

Unless otherwise stated the data are the same for all three versions of the engine, i.e. basic version, low emission version and high-altitude version.

Valve clearance, cold / warm engine

inlet valves	0.40 mm (0.016 in)
exhaust valves	0.55 mm (0.022 in)

Document Title: Specifications	Function Group: 218	Information Type: Service Information	Date: 2014/5/26
Profile:			

Specifications

Important! Nuts and bolts which are not listed here, see [Invalid linktarget] .

Engine

See also separate Service Manual for the engine.

	N m	kgf m	lbf ft
Flywheel housing — torque converter housing	78	7.8	58
Cylinder block — mounting	78	7.8	58
Mounting — tapered rubber damper	190	19	140
Rear frame — tapered rubber damper	45	4.5	33

Document Title: Specifications, L90B	Function Group: 220	Information Type: Service Information	Date: 2014/5/26
Profile:			

Specifications, L90B

Unless otherwise stated the data are the same for all three versions of the engine, i.e. basic version, low emission version and high-altitude version.

General

Oil pressure	300 - 500 kPa (3 - 5 bar) (44 - 73 psi)
Oil pressure, low idling, minimum	50 kPa (0.5 bar) (7.2 psi)
Relief valve[1] ⓘ "blue marking", opening pressure	470 kPa (4.7 bar) (68 psi)
Piston cooling valve* "red marking", opening pressure	370 kPa (3.7 bar) (54 psi)

[1]The valves are made in one piece and cannot be dismantled. The valve marked "blue" is fitted nearest the cylinder block.

Document Title: Checking rotational speed with frequency meter	Function Group: 230	Information Type: Service Information	Date: 2014/5/26
Profile:			

Checking rotational speed with frequency meter

Op nbr

Frequency meter

If the machine is not provided with a display unit and there is no service display unit available, the rotational speed can be checked with a frequency meter. The signal, which is checked, is the signal which the control unit (ECU) obtains from the speed sensor.

The following applies when checking:	
L90B:	
Low idling speed:	435 ± 20 Hz
High idling speed:	1546 ± 40 Hz
L120B:	
Low idling speed:	435 ± 20 Hz
High idling speed:	1580 ± 40 Hz
Temperature:	Normal working temperature
Units using a lot of electricity and any AC-unit should be turned off.	
Conversion factor, frequency to engine speed:	
r/s	= obtained frequency x 0.0256
1. rpm	= obtained frequency x 1.54

2. Remove the wall lining by the electrical distribution box.
3. Disconnect the connector OA from the circuit board.
4. The frequency (rotational speed) is checked in connector OA at pin 1 (signal) and at pin 2 (chassis connection), see Fig.

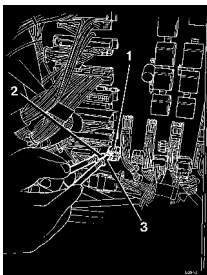

5.

Figure 1
Checking rotational speed with frequency meter

1. Connector OA

Buy Now



Our support email:

ebooklibonline@outlook.com